



US008071227B2

(12) **United States Patent**  
**Jeon et al.**

(10) **Patent No.:** **US 8,071,227 B2**  
(45) **Date of Patent:** **Dec. 6, 2011**

(54) **COMPOUNDS AND ORGANIC LIGHT  
EMITTING DIODE USING THE SAME**

(75) Inventors: **Byung-Sun Jeon**, Seoul (KR);  
**Wook-Dong Cho**, Daejeon Metropolitan  
(KR); **Jeung-Gon Kim**, Daejeon  
Metropolitan (KR); **Sang-Young Jeon**,  
Daejeon Metropolitan (KR); **Yeon-Hwan  
Kim**, Goyang-si (KR)

(73) Assignee: **LG Chem, Ltd.**, Seoul (KR)

(\* ) Notice: Subject to any disclaimer, the term of this  
patent is extended or adjusted under 35  
U.S.C. 154(b) by 389 days.

(21) Appl. No.: **12/312,856**

(22) PCT Filed: **Dec. 3, 2007**

(86) PCT No.: **PCT/KR2007/006178**

§ 371 (c)(1),  
(2), (4) Date: **May 29, 2009**

(87) PCT Pub. No.: **WO2008/066358**

PCT Pub. Date: **Jun. 5, 2008**

(65) **Prior Publication Data**

US 2010/0065828 A1 Mar. 18, 2010

(30) **Foreign Application Priority Data**

Dec. 1, 2006 (KR) ..... 10-2006-0120557

(51) **Int. Cl.**  
**H01L 51/54** (2006.01)

(52) **U.S. Cl.** ..... **428/690**; 313/504; 313/505; 313/506;  
546/42

(58) **Field of Classification Search** ..... 428/690;  
313/504, 505, 506; 546/42  
See application file for complete search history.

(56) **References Cited**

**U.S. PATENT DOCUMENTS**

6,998,487 B2 2/2006 Kim et al.  
7,138,483 B2 11/2006 Wang et al.  
2002/0107405 A1 8/2002 Lin et al.

**FOREIGN PATENT DOCUMENTS**

EP 1 671 998 6/2006

**OTHER PUBLICATIONS**

Jiang et. al., Diarylmethylene-bridged 4,4'-(bis(9-  
carbazoyl)biphenyl :morphological stable host material for highly  
efficient electrophosphorescence, 2009, J. of Materials Chemistry,  
vol. 19, pp. 7661-7665.\*

\* cited by examiner

*Primary Examiner* — Jennifer Chriss

*Assistant Examiner* — Gregory Clark

(74) *Attorney, Agent, or Firm* — McKenna Long & Aldridge  
LLP

(57) **ABSTRACT**

Disclosed are new compounds and an organic light emitting  
diode using the same. The organic light emitting diode using  
the new compound according to the present invention exhibits  
excellent characteristics in terms of actuating voltage, light  
efficiency, and lifespan.

**16 Claims, 1 Drawing Sheet**

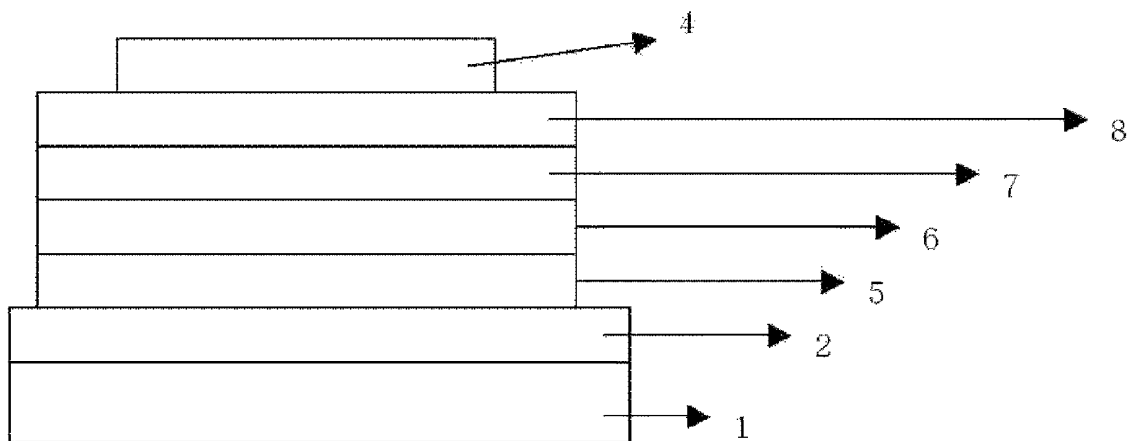

[Fig. 1]

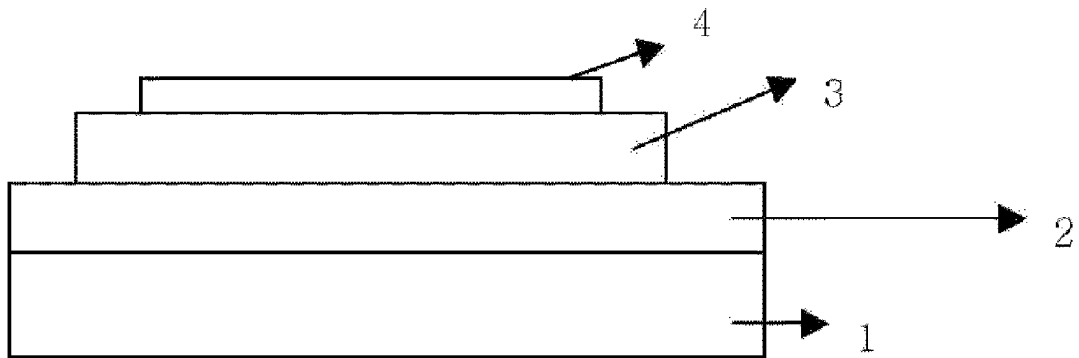

[Fig. 2]

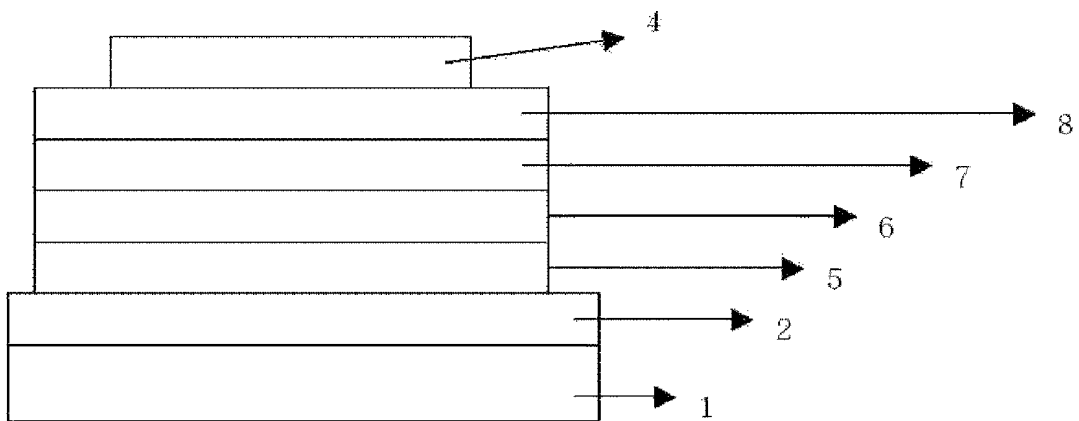

**17**

-continued

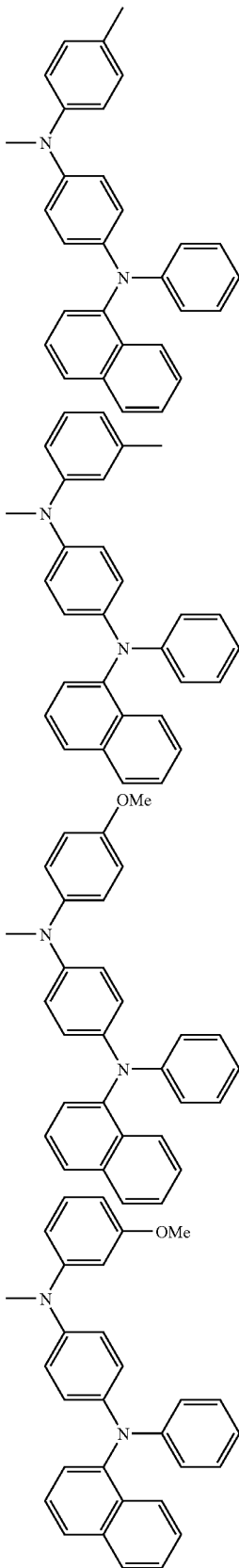

27

5

10

15

28

20

25

30

29

35

40

45

50

30

55

60

65

**18**

-continued

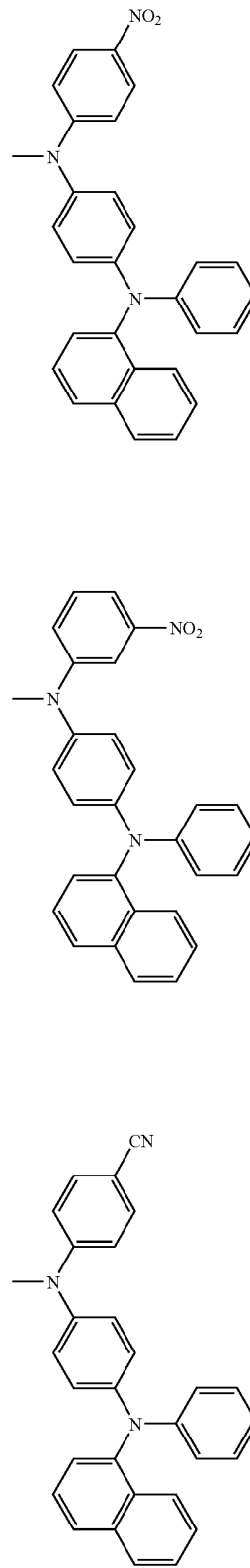

31

32

33

197

-continued

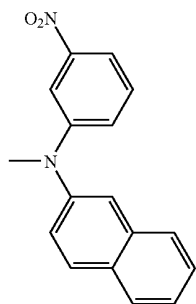
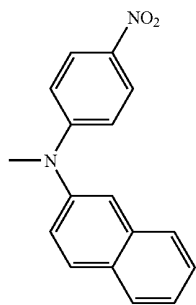
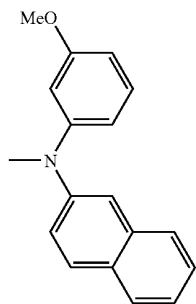
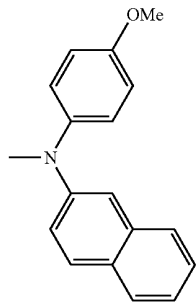
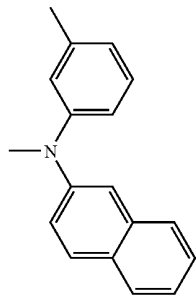

512

5

10

513

15

20

25

514

30

35

515

40

45

50

516

55

60

65

198

-continued

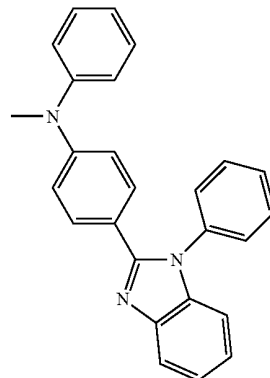
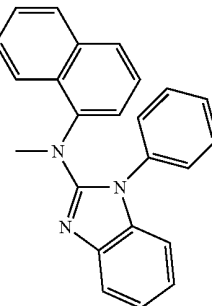
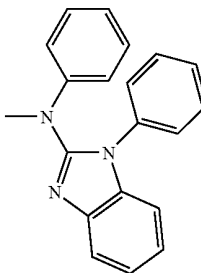
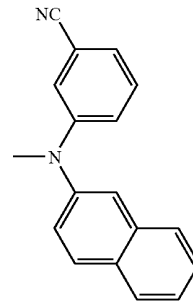
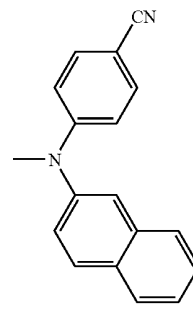

517

518

519

520

521

199

-continued

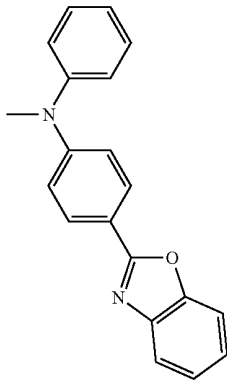
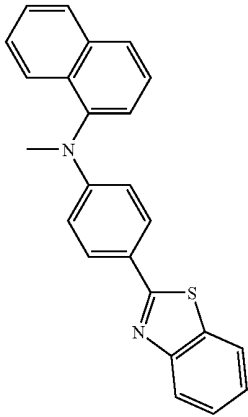
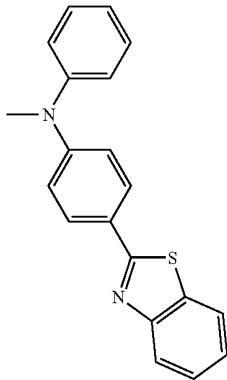
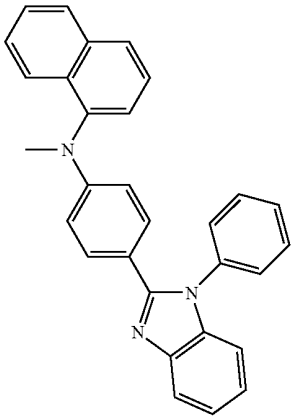

200

-continued

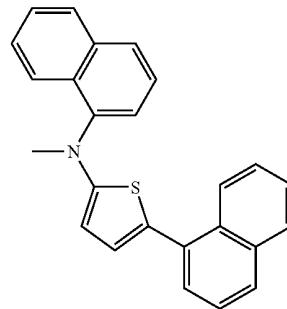
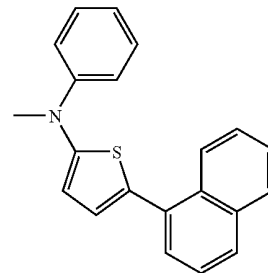
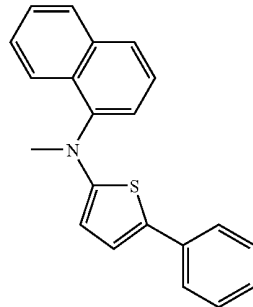
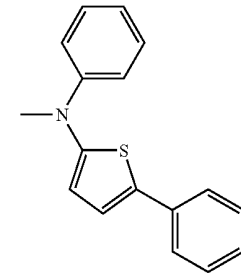
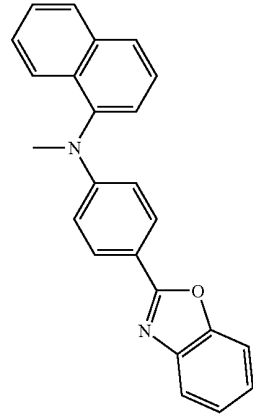

522

5

10

15

523

20

25

30

524

35

40

45

50

525

55

60

65

526

527

528

529

530

**201**  
-continued

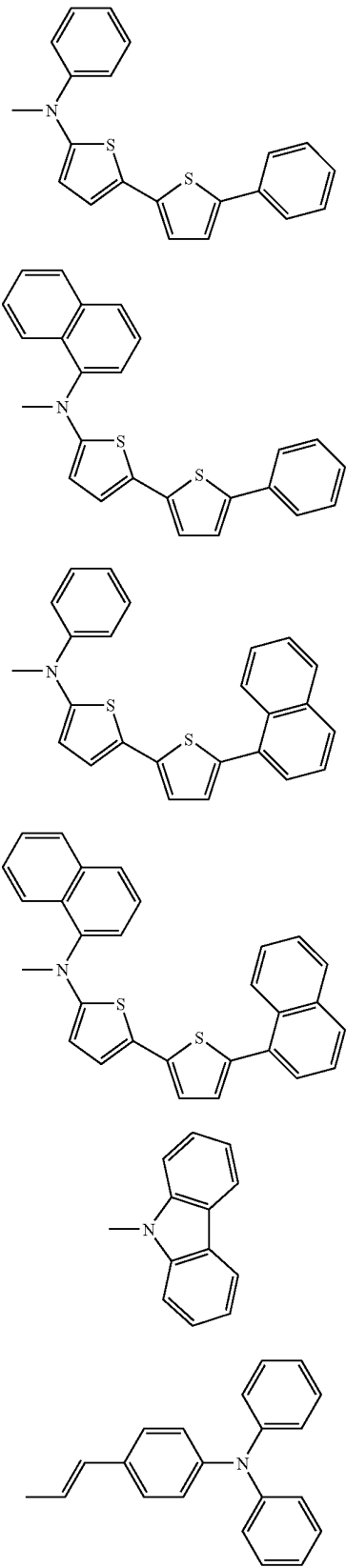

**202**  
-continued

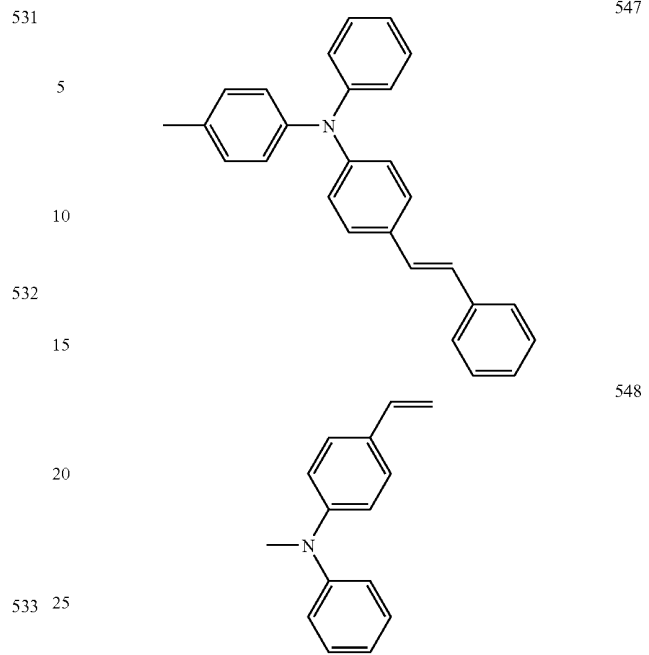

30 Various substituent groups are introduced into a core structure shown in Formula 1, in detail, the core structure in which a benzophenone group is bonded to a combination of an acridine group and a carbazole group to form an open spiro structure, thereby the compound of Formula 1 has characteristics suitable for application to an organic material layer used in an organic light emitting diode. This will be described in detail, below.

35 544 The steric core structure of the compound of Formula 1 can be divided into two portions, I and II as shown in the following Formula.

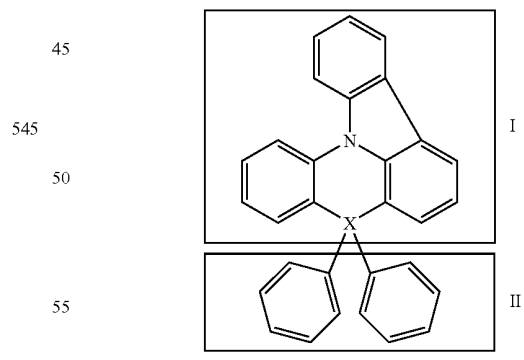

60 The compound of Formula 1 has the steric core structure, in which a plane I meets a plane II at a more planar angle being close to a right angle, unlike the closed spiro structure, in which a plane I is at a complete right angle with a plane II around X, and conjugation does not occur between the I and II portions around X. Furthermore, since one nitrogen atom is positioned among three aryl groups in the plane I, conjugation is limited in the plane I.

65

The conjugation length of the compound has a close relationship with an energy band gap. In detail, the energy band gap is reduced as the conjugation length of the compound increases. As described above, since a conjugation structure is limited in the core structure of the compound of Formula 1, the core structure has a large energy band gap.

As described above, in the present invention, various substituent groups are introduced to R1 to R13 positions and Z1 to Z8 positions of the core structure having the large energy band gap so as to produce compounds having various energy band gaps. Generally, it is easy to control the energy band gap by introducing substituent groups into a core structure having a large energy band gap, but it is difficult to significantly control the energy band gap by introducing substituent groups into a core structure having a small energy band gap. Furthermore, in the present invention, it is possible to control HOMO and LUMO energy levels of the compound by introducing various substituent groups into R1 to R13 and Z1 to Z8 positions of the core structure.

Additionally, by introducing various substituent groups into the core structure, compounds having intrinsic characteristics of the substituent groups can be obtained. For example, substituent groups, which are frequently applied to hole injection layer material, hole transport layer material, light emitting layer material, and electron transport layer materials during the production of the organic light emitting diode, are introduced into the core structure so as to produce substances capable of satisfying the requirements of each organic material layer. Particularly, since the core structure of the compound of Formula 1 includes the arylamine structure, it has an energy level suitable for the hole injection and/or hole transport materials in the organic light emitting diode. In the present invention, the compound having the proper energy level is selected depending on the substituent group among the compounds of Formula 1 to be used in the organic light emitting diode, whereby it is possible to realize a device having a low actuating voltage and a high light efficiency.

Furthermore, various substituent groups are symmetrically introduced into the core structure (the A and B portions are located at both sides of the core structure) so as to precisely control the energy band gap, improve interfacial characteristics with organic materials, and apply the compound to various fields.

In addition, if the numbers of amine contained in the substituent groups A and B are set to 2 or more (the numbers of amine contained in the substituent groups A and B are each set to 1 or more), it is possible to precisely control the HOMO or LUMO energy levels and the energy band gap, on the other hand, to improve interfacial characteristics with the organic materials, and apply the compound to various fields.

Additionally, various substituent groups are introduced into the steric structure of the compound of Formula 1 using open spiro bonding to control the three-dimensional structure of the organic material, so as to minimize  $\pi$ - $\pi$  interaction in the organic material, thereby preventing formation of excimers.

With respect to the energy band gap and the energy level, for example, since the compound of Formula 2-1-1 of Example 1 of the present invention, in which arylamine is introduced into the hole transport material or the hole injection material of the structure of Formula 1, has HOMO of 5.22 eV, it has an energy level suitable for the hole injection layer or the hole transport layer. Meanwhile, the compound of Formula 2-1-1 of Example 1 has the band gap of 2.89 eV, which is still larger than that of NPB, typically used as the hole transport layer material, thus it has a LUMO value of about 2.33 eV, which is considered to be very high. If a compound having a high LUMO value is used as the hole transport layer, it increases the energy wall of LUMO of the material constituting the light emitting layer to prevent the movement of electrons from the light emitting layer to the hole transport layer. Accordingly, the above-mentioned compound improves the light emission efficiency of the organic light emitting diode so that efficiency is higher than that of conventionally used NPB (HOMO 5.4 eV, LUMO 2.3 eV, and energy band gap 3.1 eV). In the present invention, the energy band gap is calculated by a typical method using a UV-VIS spectrum.

As well, the compound of Formula 1 has stable redox characteristics. Redox stability is estimated using a CV (cyclic voltammetry) method. For example, if oxidation voltage is repeatedly applied to the compound of Formula 2-1-1 of Example 1, oxidation repeatedly occurs at the same voltage and the current amount is constant. This means that the compound has excellent stability to oxidation.

Meanwhile, since the compound of Formula 1 has a high glass transition temperature (T<sub>g</sub>), it has excellent thermal stability. For example, the compound of Formula 2-1-1 of Example 1 of the present invention has a glass transition temperature of 172° C., which is still higher than that of conventionally used NPB (T<sub>g</sub>: 96° C.). Such increase in thermal stability is an important factor providing actuating stability to the device.

Furthermore, the compound of Formula 1 may be used to form the organic material layer using a vacuum deposition process or a solution coating process during the production of the organic light emitting diode. In connection with this, examples of the solution coating process include a spin coating process, a dip coating process, an inkjet printing process, a screen printing process, a spray process, and a roll coating process, but are not limited thereto.

Tertiary alcohol, which is produced by a reaction of a lithiated aryl and keto group, is heated in the presence of an acid catalyst to form a hexagonal cyclic structure while water is removed, thereby producing the compound of the present invention. The above-mentioned procedure for producing the compound is well known in the art, and those skilled in the art can change the production conditions during the production of the compound of Formula 1. The production will be described in detail in the preparation examples later.

Further, the present invention provides an organic light emitting diode which comprises a first electrode, at least one

205

organic material layer, and a second electrode, wherein the first electrode, the organic material layer(s), and the second electrode form a layered structure and at least one layer of the organic material layers includes a compound represented by Formula 1 of the present invention.

The organic light emitting diode of the present invention can be produced using known materials through a known process, modified only in that at least one layer of organic material layer(s) include the compound of the present invention, that is, the compound of Formula 1.

The organic material layer(s) of the organic light emitting diode according to the present invention may have a single layer structure, or alternatively, a multilayered structure in which two or more organic material layers are layered. For example, the organic light emitting diode of the present invention may comprise a hole injection layer, a hole transport layer, a light emitting layer, an electron transport layer, and an electron injection layer as the organic material layers. However, the structure of the organic light emitting diode is not limited to this, but may comprise a smaller number of organic material layers.

If the organic light emitting diode according to the present invention has a multilayered structure of organic material layer, the compound of Formula 1 can be contained in a hole injection layer, a hole transport layer, a hole injection and transport layer, a light emitting layer, and a hole transport layer. In the present invention, the compound of Formula 1 is preferably contained in a hole injection layer, a hole transport layer, or a hole injection and transport layer.

The organic light emitting diode of the present invention may be produced, for example, by sequentially layering a first electrode, organic material layer(s), and a second electrode on a substrate. In connection with this, a physical vapor deposition (PVD) method, such as a sputtering method or an e-beam evaporation method, may be used, but the method is not limited to these.

#### MODE FOR THE INVENTION

A better understanding of a method of producing a compound of Formula 1 and the production of an organic light emitting diode using the same may be obtained in light of the following preparation examples and examples which are set forth to illustrate, but are not to be construed to limit the present invention.

In order to produce the compound represented by Formula 1, any one of the compounds of the following Formulae a to b may be used as a starting material.

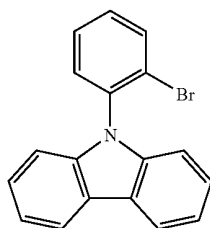

[Formula a]

206

-continued

[Formula b]

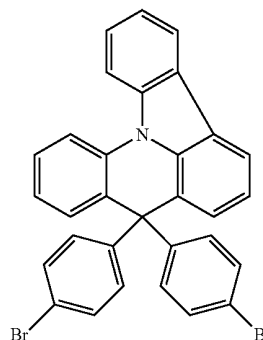

#### Preparation Example 1

##### Preparation of Starting Material Represented by Formula a

Carbazole (1.672 g, 10 mmol), 1-bromo-2-iodobenzene (1.5 ml, 12 mmol), potassium carbonate ( $K_2CO_3$ , 2.7646 g, 20 mmol), copper iodide ( $CuI$ , 95 mg, 0.5 mmol), and 25 ml of xylene were refluxed in a nitrogen atmosphere. After cooling to normal temperature was conducted, a product was extracted with ethyl acetate, water was removed with anhydrous magnesium sulfate ( $MgSO_4$ ), and the solvent was removed at a reduced pressure. The resulting product was passed through a silica gel column using a hexane solvent to produce a compound, the solvent was removed at a reduced pressure, and vacuum drying was conducted to produce the resulting white solid compound of Formula a (800 mg, yield 25%).

MS:  $[M+H]^+=323$ .

#### Preparation Example 2

##### Preparation of Starting Material Represented by Formula b

The starting material represented by Formula a (6.96 g, 21.6 mmol) was dissolved in 300 ml of purified THF (tetrahydrofuran) and cooled to  $-78^\circ C.$ , and  $n-BuLi$  (2.5 M in hexane, 8.64 ml, 21.6 mmol) was slowly dropped thereon. Stirring was conducted at the same temperature for 30 min, and 4,4'-dibromobenzophenone (6.12 g, 18.0 mmol) was added thereto. After stirring was conducted at the same temperature for 40 min, the temperature was raised to normal temperature and stirring was carried out for an additional 3 hours. The reaction was completed in an ammonium chloride ( $NH_4Cl$ ) aqueous solution, and extraction was conducted with ethyl ether. Water was removed from an organic material layer using anhydrous magnesium sulfate ( $MgSO_4$ ), and an organic solvent was then removed therefrom. The produced solid was dispersed in ethanol, stirred for one day, filtered, and vacuum dried to produce 10.12 g of intermediate material (96.4% yield). The intermediate solid was dispersed in 10 ml of acetic acid, ten drops of concentrated sulfuric acid were added thereto, and reflux was conducted for 4 hours. The resulting solid was filtered, washed with ethanol, and vacuum dried to produce 9.49 g of compound of Formula b (yield 96.8%).

MS:  $[M+H]^+=565$ .

Preparation of Compound Represented by Following  
Formula 2-1-1

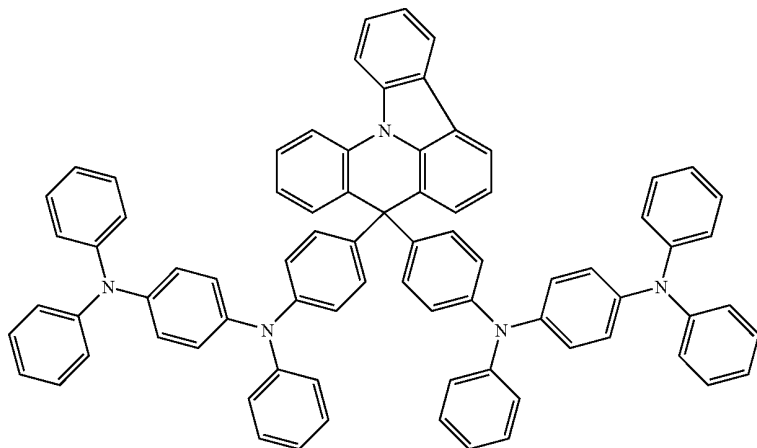

[Formula 2-1-1]

1) Production of arylamine (4-(N-phenyl-N-phenylamino)phenyl-1-phenylamine) to produce the compound represented by Formula 2-1-1

4-bromophenyl-N-phenyl-N-phenylamine (13.5 g, 41.6 mmol) and aniline (3.98 ml, 43.7 mmol) were dissolved in 120 ml of toluene, sodium-tertiary-butoxide (10.00 g, 104.1 mmol), bisdibenzylidene acetone palladium (0) (0.48 g, 0.83 mmol), and 50 wt % tri-tertiary-butylphosphine toluene solution (0.58 ml, 1.25 mmol) were added thereto, and reflux was conducted in a nitrogen atmosphere for 2 hours. Distilled water was added to the reaction solution to complete the reaction, and the organic layer was extracted. A column separation process was conducted using a solvent of n-hexane and tetrahydrofuran (n-hexane/THF=10/1), stirring was conducted using petroleum ether, and vacuum drying was conducted to produce an arylamine connection group (9.6 g, yield 69%).

MS: [M+H]<sup>+</sup>=336.

2) The compound of Formula b (3.0 g, 5.3 mmol) and 4-(N-phenyl-N-phenylamino)phenyl-1-phenylamine (4.12

g, 12.3 mmol) were dissolved in 80 ml of toluene, and sodium-tertiary-butoxide (1.54 g, 16.0 mmol), bis-dibenzylidene acetone palladium(0) (0.06 g, 0.11 mmol), and 50 wt % tri-tertiary-butylphosphine toluene solution (0.06 ml, 0.16 mmol) were added thereto. After reflux was conducted in a nitrogen atmosphere for 2 hours, distilled water was added to the reaction solution to complete the reaction. The organic layer was extracted, and a column separation process was conducted using a solvent of n-hexane and tetrahydrofuran (n-hexane/THF=4/1), stirring was conducted using petroleum ether, and vacuum drying was conducted to produce the compound of Formula 2-1-1 (2.7 g, yield 47%).

MS: [M+H]<sup>+</sup>=1076.

### Example 2

Preparation of Compound Represented by Following  
Formula 2-2-2

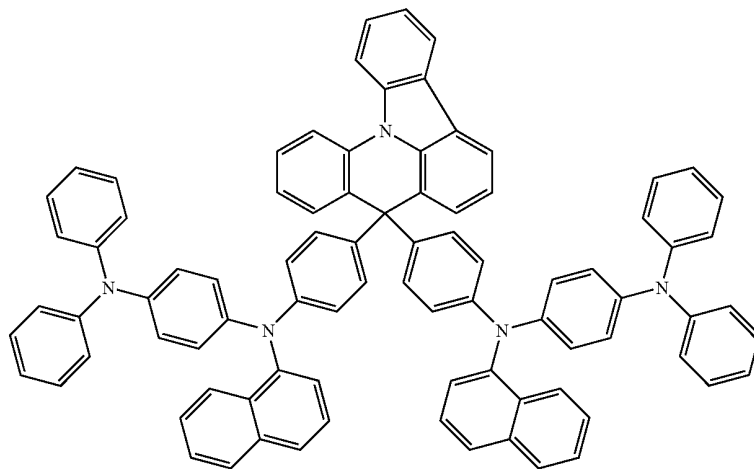

[Formula 2-2-2]

1) Production of arylamine (4-(N-phenyl-N-phenylamino)phenyl-1-naphthylamine) to produce the compound represented by Formula 2-2-2

4-bromophenyl-N-phenyl-N-phenylamine (15.0 g, 46.3 mmol) and 1-naphthylamine (7.29 g, 50.9 mmol) were dissolved in 200 ml of toluene, sodium-tertiary-butoxide (13.34 g, 138.8 mmol), bis(dibenzylidene acetone palladium (0) (0.53 g, 0.93 mmol), and 50 wt % tri-tertiary-butylphosphine toluene solution (0.56 ml, 1.39 mmol) were added thereto, and reflux was conducted in a nitrogen atmosphere for 2 hours. Distilled water was added to the reaction solution to complete the reaction, and the organic layer was extracted. A column separation process was conducted using a solvent of n-hexane and tetrahydrofuran (n-hexane/THF=10/1), stirring was conducted using petroleum ether, and vacuum drying was conducted to produce an arylamine connection group (13 g, yield 73%).

MS:  $[M+H]^+=386$ .

2) The compound of Formula b (5.00 g, 8.88 mmol) and 4-(N-phenyl-N-phenylamino)phenyl-1-naphthylamine (7.90 g, 20.4 mmol) were dissolved in 120 ml of toluene, and sodium-tertiary-butoxide (5.89 g, 61.3 mmol), tris-dibenzylidene acetone palladium(0) (0.24 g, 0.41 mmol), and 50 wt % tri-tertiary-butylphosphine toluene solution (0.25 ml, 0.61 mmol) were added thereto. After reflux was conducted in a nitrogen atmosphere for 2 hours, distilled water was added to the reaction solution to complete the reaction. The organic layer was extracted, and a column separation process was conducted using a solvent of n-hexane and tetrahydrofuran (n-hexane/THF=4/1), stirring was conducted using petroleum ether, and vacuum drying was conducted to produce the compound of Formula 2-2-2 (5.2 g, yield 50%).

MS:  $[M+H]^+=1176$ .

### Example 3

Preparation of Compound Represented by Following Formula 2-4-4

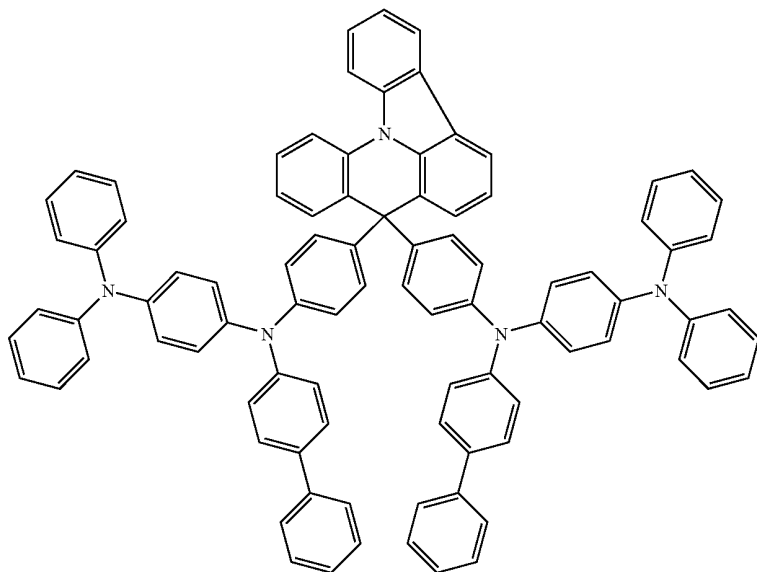

1) Production of arylamine (4-(N-phenyl-N-phenylamino)phenyl-1-biphenylamine) to produce the compound represented by Formula 2-4-4

4-bromophenyl-N-phenyl-N-phenylamine (17.4 g, 53.7 mmol) and 4-aminobiphenyl (9.99 g, 59.0 mmol) were dissolved in 250 ml of toluene, sodium-tertiary-butoxide (17.02 g, 177.1 mmol), bis(dibenzylidene acetone palladium (0) (0.68 g, 1.2 mmol), and 50 wt % tri-tertiary-butylphosphine toluene solution (0.72 ml, 1.8 mmol) were added thereto, and reflux was conducted in a nitrogen atmosphere for 2 hours. Distilled water was added to the reaction solution to complete the reaction, and the organic layer was extracted. A column separation process was conducted using a solvent of n-hexane and tetrahydrofuran (n-hexane/THF=10/1), stirring was conducted using petroleum ether, and vacuum drying was conducted to produce an arylamine connection group (16 g, yield 73%).

MS:  $[M+H]^+=412$ .

2) The Compound of Formula b (4.7 g, 8.3 mmol) and 4-(N-phenyl-N-phenylamino)phenyl-1-biphenylamine (7.9 g, 19.2 mmol) were dissolved in 150 ml of toluene, and sodium-tertiary-butoxide (5.53 g, 57.5 mmol), bis-dibenzylidene acetone palladium(0) (0.22 g, 0.38 mmol), and 50 wt % tri-tertiary-butylphosphine toluene solution (0.23 ml, 0.58 mmol) were added thereto. After reflux was conducted in a nitrogen atmosphere for 2 hours, distilled water was added to the reaction solution to complete the reaction. The organic layer was extracted, and a column separation process was conducted using a solvent of n-hexane and tetrahydrofuran (n-hexane/THF=4/1), stirring was conducted using petroleum ether, and vacuum drying was conducted to produce the compound of Formula 2-4-4 (4.9 g, yield 48%).

MS:  $[M+H]^+=1227$ .

[Formula 2-4-4]

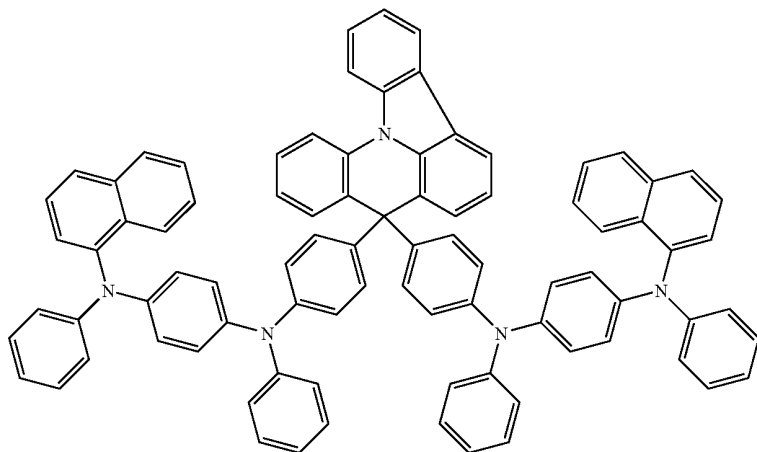
Preparation of Compound Represented by Following  
Formula 2-18-18

[Formula 2-18-18]

1) Production of arylamine (4-(N-phenyl-N-naphthylamino)phenyl-1-phenylamine) to produce the compound represented by Formula 2-18-18

4-bromophenyl-N-phenyl-N-naphthylamine (7.00 g, 18.7 mmol) and aniline (2.56 ml, 28.1 mmol) were dissolved in 100 ml of toluene, sodium-tertiary-butoxide (5.40 g, 56.1 mmol), bisdibenzylidene acetone palladium (0) (0.22 g, 0.37 mmol), and 50 wt % tri-tertiary-butylphosphine toluene solution (0.28 ml, 0.37 mmol) were added thereto, and reflux was conducted in a nitrogen atmosphere for 2 hours. Distilled water was added to the reaction solution to complete the reaction, and the organic layer was extracted. A column separation process was conducted using a solvent of n-hexane and tetrahydrofuran (n-hexane/THF=10/1), stirring was conducted using petroleum ether, and vacuum drying was conducted to produce an arylamine connection group (5.1 g, yield 70%).

MS:  $[M+H]^+=386$ .

2) The Compound of Formula b (2.5 g, 4.4 mmol) and 4-(N-phenyl-N-naphthylamino)phenyl-1-phenylamine (3.86

g, 10.0 mmol) were dissolved in 50 ml of toluene, and sodium-tertiary-butoxide (1.26 g, 13.2 mmol), tris-dibenzylidene acetone palladium(0) (0.08 g, 0.08 mmol), and 50 wt % tri-tertiary-butylphosphine toluene solution (0.04 ml, 0.13 mmol) were added thereto. After reflux was conducted in a nitrogen atmosphere for 2 hours, distilled water was added to the reaction solution to complete the reaction. The organic layer was extracted, and a column separation process was conducted using a solvent of n-hexane and tetrahydrofuran (n-hexane/THF=4/1), stirring was conducted using petroleum ether, and vacuum drying was conducted to produce the compound of Formula 2-18-18 (2.5 g, yield 49%).

MS:  $[M+H]^+=1175$ .

## Example 5

Preparation of Compound Represented by Following  
Formula 2-19-19

[Formula 2-19-19]

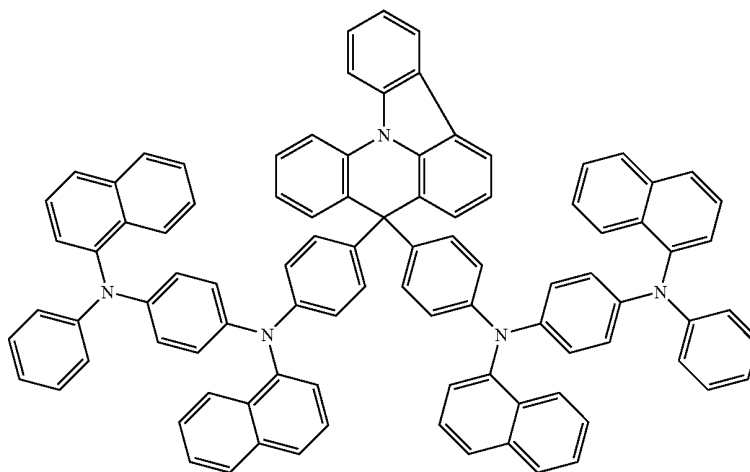

## 213

1) Production of arylamine (4-(N-phenyl-N-naphthylamino)phenyl-1-naphthylamine) to produce the compound represented by Formula 2-19-19

4-bromophenyl-N-phenyl-N-naphthylamine (14.0 g, 37.4 mmol) and 1-naphthylamine (6.43 g, 44.9 mmol) were dissolved in 200 ml of toluene, bis-dibenzylidene acetone palladium (0) (0.645 g, 1.12 mmol), 50 wt % tri-tertiary-butylphosphine toluene solution (0.74 ml, 1.5 mmol), and sodium-tertiary-butoxide (8.99 g, 93.5 mmol) were added thereto, and reflux was conducted in a nitrogen atmosphere for 2 hours. Distilled water was added to the reaction solution to complete the reaction, and the organic layer was extracted. A column separation process was conducted using a solvent of n-hexane and tetrahydrofuran (n-hexane/THF=10/1), stirring was conducted using petroleum ether, and vacuum drying was conducted to produce an arylamine connection group (8.53 g, yield 52.2%).

MS: [M+H]<sup>+</sup>=437.

2) The Compound of Formula b (5.00 g, 8.88 mmol) and 4-(N-phenyl-N-naphthylamino)phenyl-1-naphthylamine (8.53 g, 19.5 mmol) were dissolved in 50 ml of toluene, and bisdibenzylidene acetone palladium(0) (0.204 g, 0.360 mmol), 50 wt % tri-tertiary-butylphosphine toluene solution (0.31 ml, 0.62 mmol) and sodium-tertiary-butoxide (4.69 g, 48.8 mmol) were added thereto. After reflux was conducted in a nitrogen atmosphere for 2 hours, distilled water was added to the reaction solution to complete the reaction. The organic layer was extracted, and a column separation process was conducted using a solvent of n-hexane and tetrahydrofuran (n-hexane/THF=8/1), stirring was conducted using petroleum ether, and vacuum drying was conducted to produce the compound of Formula 2-19-19 (5.60 g, yield 49.5%).

MS: [M+H]<sup>+</sup>=1229.

## Example 6

Preparation of Compound Represented by Following Formula 2-21-21

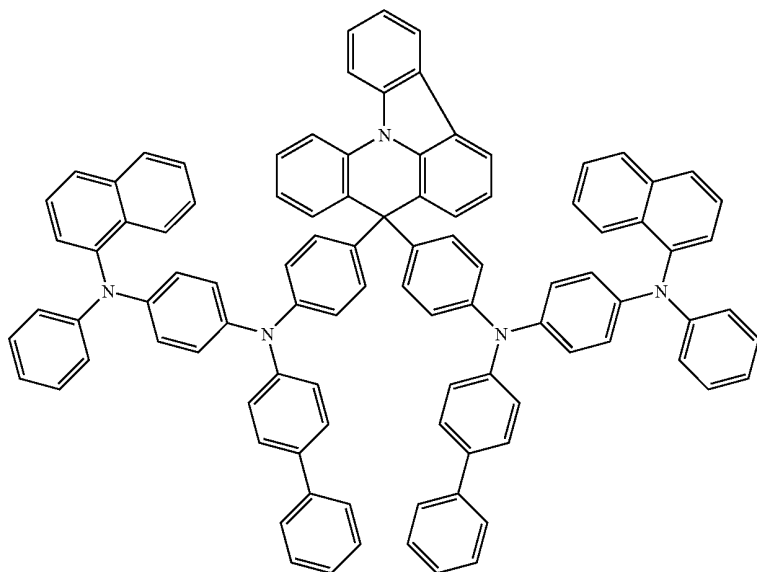

## 214

1) Production of arylamine (4-(N-phenyl-N-naphthylamino)phenyl-1-biphenylamine) to produce the compound represented by Formula 2-21-21

4-bromophenyl-N-phenyl-N-naphthylamine (14.0 g, 37.4 mmol) and 4-aminobiphenyl (6.96 g, 41.2 mmol) were dissolved in 200 ml of toluene, bis-dibenzylidene acetone palladium (0) (0.47 g, 0.82 mmol), 50 wt % tri-tertiary-butylphosphine toluene solution (0.50 ml, 1.2 mmol), and sodium-tertiary-butoxide (11.86 g, 123.4 mmol) were added thereto, and reflux was conducted in a nitrogen atmosphere for 2 hours. Distilled water was added to the reaction solution to complete the reaction, and the organic layer was extracted. A column separation process was conducted using a solvent of n-hexane and tetrahydrofuran (n-hexane/THF=10/1), stirring was conducted using petroleum ether, and vacuum drying was conducted to produce an arylamine connection group (7.5 g, yield 43%).

MS: [M+H]<sup>+</sup>=462.

2) The Compound of Formula b (3.3 g, 5.8 mmol) and 4-(N-phenyl-N-naphthylamino)phenyl-1-biphenylamine (5.90 g, 12.8 mmol) were dissolved in 70 ml of toluene, and bisdibenzylidene acetone palladium(0) (0.15 g, 0.26 mmol), 50 wt % tri-tertiary-butylphosphine toluene solution (0.16 ml, 0.38 mmol) and sodium-tertiary-butoxide (3.68 g, 38.3 mmol) were added thereto. After reflux was conducted in a nitrogen atmosphere for 2 hours, distilled water was added to the reaction solution to complete the reaction. The organic layer was extracted, and a column separation process was conducted using a solvent of n-hexane and tetrahydrofuran (n-hexane/THF=8/1), stirring was conducted using petroleum ether, and vacuum drying was conducted to produce the compound of Formula 2-21-21 (3.9 g, yield 51%).

MS: [M+H]<sup>+</sup>=1229.

[Formula 2-21-21]

Preparation of Compound Represented by Following  
Formula 2-256-256

[Formula 2-256-256]

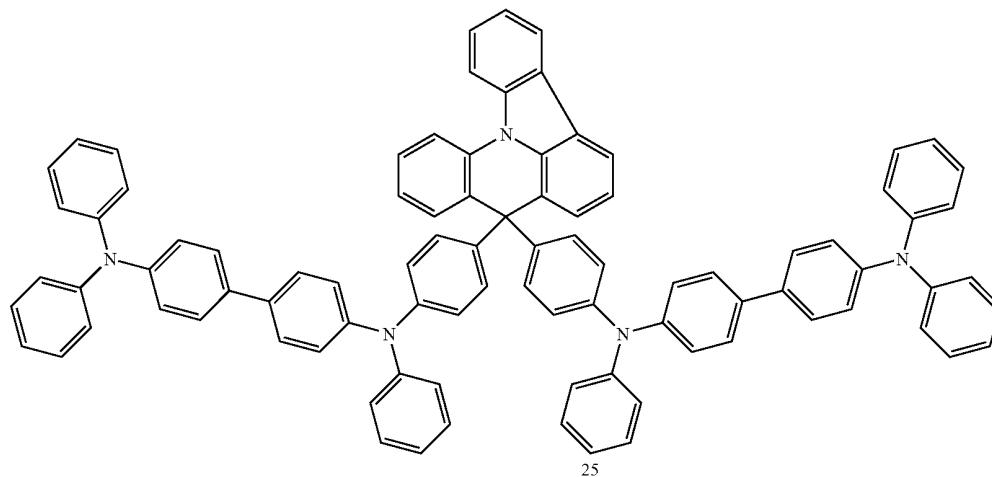

1) Production of arylamine (4-(N,N-diphenylamino)-biphenyl-aniline) to produce the compound represented by Formula 2-256-256

4-chlorobiphenyl-N,N-diphenylamine (4.00 g, 11.2 mmol) and aniline (1.13 ml, 12.4 mmol) were dissolved in 100 ml of toluene, bis(dibenzylidene acetone palladium(0)) (0.129 g, 0.225 mmol), 50 wt % tri-tertiary-butylphosphine toluene solution (0.17 ml, 0.34 mmol), and sodium-tertiary-butoxide (2.70 g, 28.1 mmol) were added thereto, and reflux was conducted in a nitrogen atmosphere for 5 hours. Distilled water was added to the reaction solution to complete the reaction, and the organic layer was extracted. A column separation process was conducted using a solvent of n-hexane and tetrahydrofuran (n-hexane/THF=10/1), stirring was conducted using petroleum ether, and vacuum drying was conducted to produce an arylamine connection group as an amine derivative (3.77 g, yield 81.3%).

MS:  $[M+H]^+=413$ .

2) The Compound of Formula b (2.30 g, 4.08 mmol) and 4-(N,N-diphenylamino)-biphenyl-aniline (3.70 g, 8.97

mmol) were dissolved in 30 ml of toluene, and bis(dibenzylidene acetone palladium(0)) (0.094 g, 0.16 mmol), 50 wt % tri-tertiary-butylphosphine toluene solution (0.14 ml, 0.29 mmol) and sodium-tertiary-butoxide (2.16 g, 22.4 mmol) were added thereto. After reflux was conducted in a nitrogen atmosphere for 2 hours, distilled water was added to the reaction solution to complete the reaction. The organic layer was extracted, and a column separation process was conducted using a solvent of n-hexane and tetrahydrofuran (n-hexane/THF=8/1), stirring was conducted using petroleum ether, and vacuum drying was conducted to produce the compound of Formula 2-256-256 (2.7 g, yield 54%).

MS:  $[M+H]^+=1229$ .

### Example 8

Preparation of Compound Represented by Following  
Formula 3-2-2

[Formula 3-2-2]

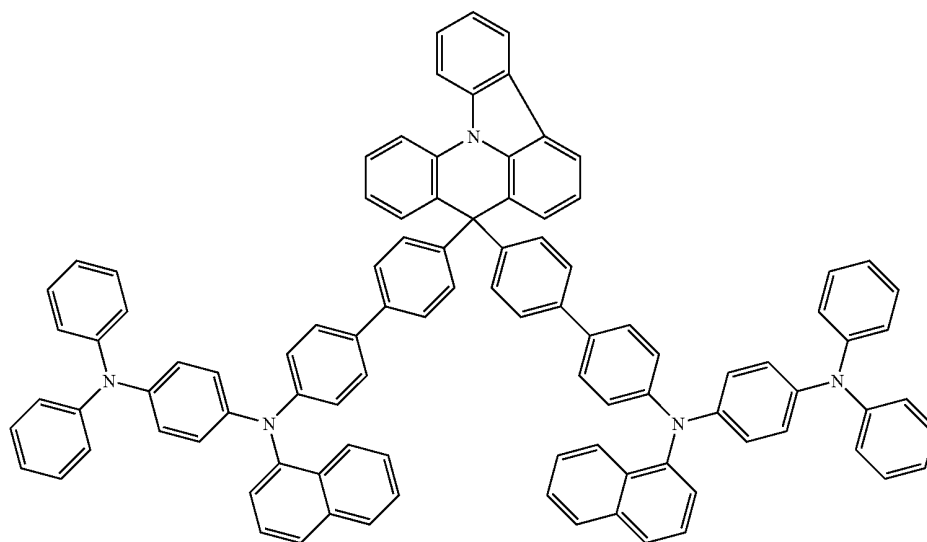

**19**  
-continued

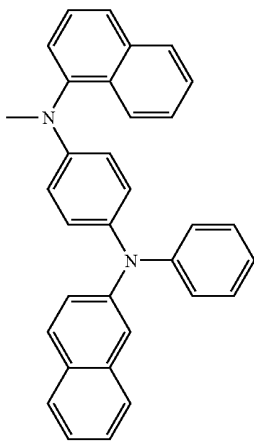
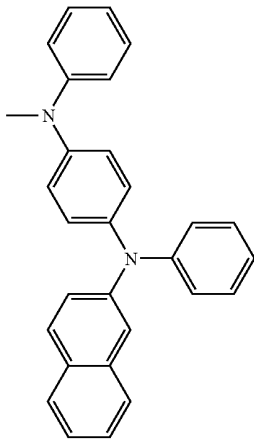
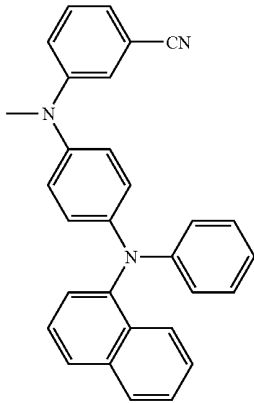

**20**  
-continued

34 5

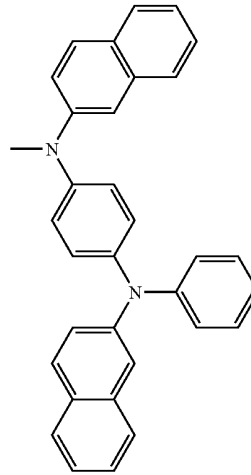

37

10

15

20

25

35

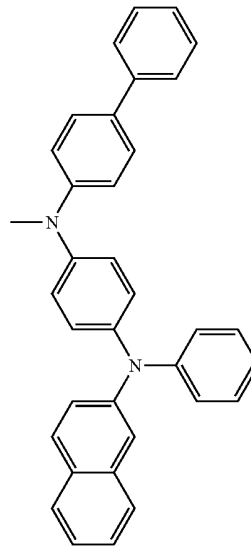

38

30

35

40

45

36

50

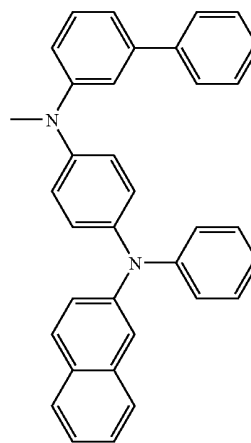

39

55

60

65

217

1) Production of arylamine (4-(N-phenyl-N-phenylamino)phenyl-1-naphthylamine) to produce the compound represented by Formula 3-2-2

Synthesis was conducted through the same procedure as in synthesis of the arylamine connection group of the compound represented by Formula 2-2-2.

2) The starting material represented by Formula b (10.0 g, 17.8 mmol) was completely dissolved in 200 ml of THF, 4-chloro-phenylboronic acid (8.30 g, 53.3 mmol), 2 M potassium carbonate solution, tetrakis(triphenylphosphine)palladium(0) (0.62 g, 0.53 mmol), and 10 ml of ethanol were added thereto, and reflux was conducted for 24 hours. After the reaction was completed, cooling to normal temperature was conducted, and filtration was conducted. Washing was conducted with water and ethanol several times. Recrystallization was conducted with ethanol, and vacuum drying was conducted to produce a compound (9.5 g, 85% yield).

MS:  $[M+H]^+=627$ .

The compound obtained by the above reaction (5.00 g, 7.98 mmol) and 4-(N-phenyl-N-phenylamino)phenyl-1-naphthylamine (7.09 g, 18.4 mmol) were dissolved in 120 ml of toluene, and sodium-tertiary-butoxide (5.29 g, 55.0 mmol), bis-dibenzylidene acetone palladium(0) (0.21 g, 0.37 mmol), and 50 wt % tri-tertiary-butylphosphine toluene solution (0.22 ml, 0.55 mmol) were added thereto. After reflux was conducted in a nitrogen atmosphere for 2 hours, distilled water was added to the reaction solution to complete the reaction. The organic layer was extracted, and a column separation process was conducted using a solvent of n-hexane and tetrahydrofuran (n-hexane/THF=4/1), stirring was conducted using petroleum ether, and vacuum drying was conducted to produce the compound of Formula 3-2-2 (5.6 g, yield 53%).

MS:  $[M+H]^+=1327$ .

### Experimental Example 1

#### Production of Organic Light Emitting Diode

A glass substrate (corning 7059 glass), on which ITO (indium tin oxide) was applied to a thickness of 1,000 to form a thin film, was put in distilled water, in which a detergent was dissolved, and washed using ultrasonic waves. In connection with this, a product manufactured by Fischer Co. was used as the detergent, and distilled water was produced by filtering twice using a filter manufactured by Millipore Co. After ITO was washed for 30 min, ultrasonic washing was conducted twice using distilled water for 10 min. After the washing using distilled water was completed, ultrasonic washing was conducted using isopropyl alcohol, acetone, and methanol solvents, and drying was then conducted. Next, it was transported to a plasma washing machine. Furthermore, the substrate was dry washed using oxygen plasma for 5 min, and then transported to a vacuum evaporator.

Hexanitride hexaazatriphenylene (hereinafter, referred to as "HAT") of the following Formula was vacuum deposited to a thickness of 80 by heating on a transparent ITO electrode, which was prepared through the above procedure, so as to form an anode including an ITO conductive layer and an N-type organic material. Interfacial characteristic between the substrate and hole injection layer can be improved by the anode. Subsequently, the compound of Formula 2-1-1 was deposited to a thickness of 800 on the thin film to form a hole injection layer.

218

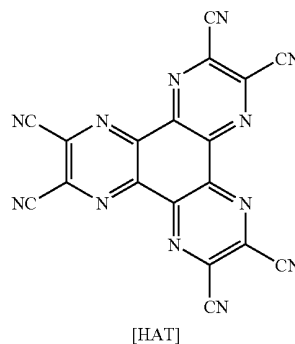

NPB was deposited to a thickness of 300 on the layer to form a hole transport layer. Then, Alq<sub>3</sub> was deposited to a thickness of 300 on the hole transport layer to form a light emitting layer. An electron transport layer material of the following Formula was deposited to a thickness of 200 on the light emitting layer to form an electron transport layer.

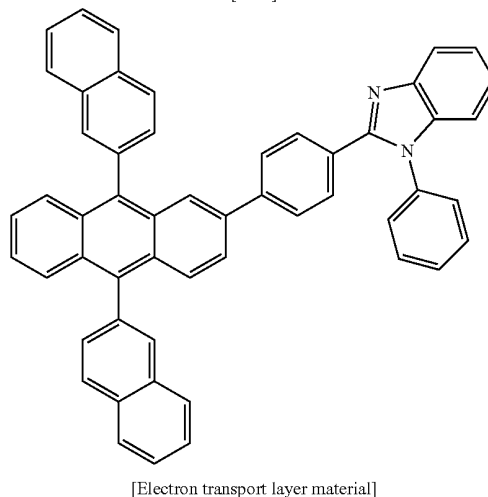
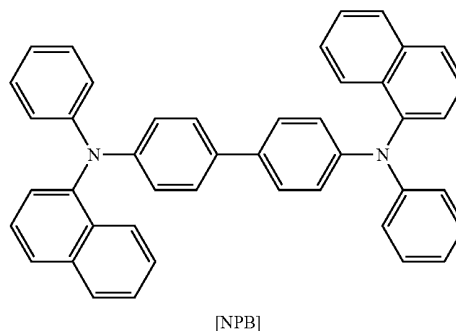

Lithium fluoride (LiF) having a thickness of 12 and aluminum having a thickness of 2,000 were sequentially deposited on the electron transport layer to form a cathode.

In the above procedure, the deposition speed of an organic material was maintained at 0.3 to 0.8 Å/sec. Furthermore, lithium fluoride and aluminum were deposited at speeds of 0.3 Å/sec and 1.5 to 2.5 Å/sec, respectively, on the cathode. During the deposition, a vacuum was maintained at 1 to 3 10<sup>-7</sup>.

## 219

The resulting device had an electric field of 8.78 V at a forward current density of 100 mA/cm<sup>2</sup>, and a spectrum having a light efficiency of 2.01 lm/W. The operation and light emission of the device at the above-mentioned actuating voltage mean that the compound of Formula 2-1-1, which formed the layer between the thin film formed on the substrate and the hole transport layer, functions to inject holes.

## Experimental Example 2

## Production of Organic Light Emitting Diode

The procedure of Example 1 was repeated to produce a device except that the compound of Formula 2-1-1 used as a hole injection layer was substituted with the compound of Formula 2-2-2.

The resulting device had an electric field of 8.75 V at a forward current density of 100 mA/cm<sup>2</sup>, and a spectrum having a light efficiency of 2.01 lm/W.

## Experimental Example 3

## Production of Organic Light Emitting Diode

The procedure of Experimental Example 1 was repeated to produce a device except that the compound of Formula 2-1-1 used as a hole injection layer was substituted with the compound of Formula 2-4-4.

The resulting device had an electric field of 7.36 V at a forward current density of 100 mA/cm<sup>2</sup>, and a spectrum having a light efficiency of 2.12 lm/W.

## Experimental Example 4

## Production of Organic Light Emitting Diode

The procedure of Experimental Example 1 was repeated to produce a device except that the compound of Formula 2-1-1 used as a hole injection layer was substituted with the compound of Formula 2-18-18.

The resulting device had an electric field of 8.58 V at a forward current density of 100 mA/cm<sup>2</sup>, and a spectrum having a light efficiency of 1.97 lm/W.

## Experimental Example 5

## Production of Organic Light Emitting Diode

The procedure of Experimental Example 1 was repeated to produce a device except that the compound of Formula 2-1-1 used as a hole injection layer was substituted with the compound of Formula 2-19-19.

The resulting device had an electric field of 9.20 V at a forward current density of 100 mA/cm<sup>2</sup>, and a spectrum having a light efficiency of 2.36 lm/W.

## Experimental Example 6

## Production of Organic Light Emitting Diode

The procedure of Experimental Example 1 was repeated to produce a device except that the compound of Formula 2-1-1 used as a hole injection layer was substituted with the compound of Formula 2-21-21.

The resulting device had an electric field of 8.18 V at a forward current density of 100 mA/cm<sup>2</sup>, and a spectrum having a light efficiency of 2.67 lm/W.

## 220

## Experimental Example 7

## Production of Organic Light Emitting Diode

The procedure of Experimental Example 1 was repeated to produce a device except that the compound of Formula 2-1-1 used as a hole injection layer was substituted with the compound of Formula 2-256-256.

The resulting device had an electric field of 6.79 V at a forward current density of 100 mA/cm<sup>2</sup>, and a spectrum having a light efficiency of 1.83 lm/W.

## Example 8

## Production of Organic Light Emitting Diode

The procedure of Experimental Example 1 was repeated to produce a device except that the compound of Formula 2-1-1 used as a hole injection layer was substituted with the compound of Formula 3-2-2.

The resulting device had an electric field of 8.91 V at a forward current density of 100 mA/cm<sup>2</sup>, and a spectrum having a light efficiency of 2.08 lm/W.

The invention claimed is:

1. A compound represented by the following Formula 1:

[Formula 1]

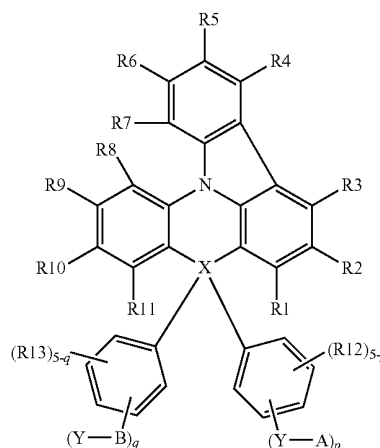

wherein, X is C or Si,

Ys are the same or different from each other, and each independently directly connected to each other; bivalent aromatic hydrocarbons; bivalent aromatic hydrocarbons which are substituted with at least one substituent group selected from the group consisting of nitro, nitrile, halogen, alkyl, alkoxy, and amino groups; a bivalent heterocyclic group; or a bivalent heterocyclic group which is substituted with at least one substituent group selected from the group consisting of nitro, nitrile, halogen, alkyl, alkoxy, and amino groups,

R1 to R11 are the same or different from each other, and each independently hydrogen, a substituted or unsubstituted alkyl group, a substituted or unsubstituted alkoxy group, a substituted or unsubstituted alkenyl group, a substituted or unsubstituted aryl group, a substituted or unsubstituted arylamine group, a substituted or unsubstituted heterocyclic group, an amino group, a nitrile group, a nitro group, a halogen group, an amide group, or

221

an ester group, in which they may form aliphatic, aromatic or hetero condensation rings along with adjacent groups,

R12 and R13 are the same or different from each other, and each independently hydrogen, a substituted or unsubstituted alkyl group, a substituted or unsubstituted alkoxy group, a substituted or unsubstituted alkenyl group, a substituted or unsubstituted aryl group, a substituted or unsubstituted heterocyclic group, an amino group, a nitrile group, a nitro group, a halogen group, an amide group, or an ester group, in which they may form aliphatic, aromatic or hetero condensation rings along with adjacent groups,

R7 and R8 are directly connected to each other, or form a condensation ring along with a group selected from the group consisting of O, S, NR, PR, C=O, CRR' and SiRR' in which R and R' are the same or different from each other, each independently hydrogen, a substituted or unsubstituted alkyl group, a substituted or unsubstituted alkoxy group, a substituted or unsubstituted alkenyl group, a substituted or unsubstituted aryl group, a substituted or unsubstituted arylamine group, a substituted or unsubstituted heterocyclic group, a nitrile group, an amide group, or an ester group, and may form a condensation ring to form a spiro compound,

p and q are each independently an integer of 1 to 5, with the proviso that when p is an integer of 2 or more, q is 1, and when q is an integer of 2 or more, p is 1,

A is

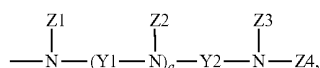

B is

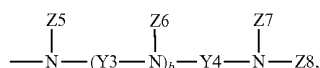

a and b are each independently an integer of 0 to 10,

Y1 to Y4 are the same or different from each other, and each independently bivalent aromatic hydrocarbons; bivalent aromatic hydrocarbons which are substituted with at least one substituent group selected from the group consisting of nitro, nitrile, halogen, alkyl, alkoxy, and amino groups; a bivalent heterocyclic group; or a bivalent heterocyclic group which is substituted with at least one substituent group selected from the group consisting of nitro, nitrile, halogen, alkyl, alkoxy and amino groups, and

Z1 to Z8 are the same or different from each other, and each independently hydrogen; aliphatic hydrocarbons having 1 to 20 carbon atoms; aromatic hydrocarbons; aromatic hydrocarbons which are substituted with at least one substituent group selected from the group consisting of nitro, nitrile, halogen, alkyl, alkoxy, amino, aromatic hydrocarbon, and heterocyclic groups; a silicon group substituted with aromatic hydrocarbons; a heterocyclic group; a heterocyclic group which is substituted with at least one substituent group selected from the group consisting of nitro, nitrile, halogen, alkyl, alkoxy, amino, aromatic hydrocarbon, and heterocyclic groups; a thiophene group which is substituted with aliphatic hydrocarbons having 1 to 20 carbon atoms or aromatic

222

hydrocarbons having 6 to 20 carbon atoms; or a boron group which is substituted with aromatic hydrocarbons.

2. The compound according to claim 1, wherein the bivalent aromatic hydrocarbon of Y and Y1 to Y4 of Formula 1 is selected from the group consisting of phenylene, biphenylene, terphenylene, naphthylene, anthracenylene, pyrenylene, and perylenylene.

3. The compound according to claim 1, wherein the bivalent heterocyclic group of Y and Y1 to Y4 of Formula 1 is selected from the group consisting of thio-phenylene, furylene, pyrrolylene, imidazolylene, thiazolylene, oxazolylene, oxa-diazolylene, thiadiazolylene, triazolylene, pyridylene, pyridazylene, pyrazinylene, quinolylene, and isoquinolylene.

4. The compound according to claim 1, wherein the aromatic hydrocarbon of Z1 to Z8 of Formula 1 is selected from the group consisting of phenyl, biphenyl, terphenyl, naphthyl, anthracenyl, pyrenyl, and perylenyl.

5. The compound according to claim 1, wherein the heterocyclic group of Z1 to Z8 of Formula 1 is selected from the group consisting of thiophene, furan, pyrrole, imidazole, thiazole, oxazole, oxadiazole, thiadiazole, triazole, pyridyl, pyridazyl, pyrazine, quinoline, and isoquinoline.

6. The compound according to claim 1, wherein the aliphatic hydrocarbon having 1 to 20 carbon atoms of Z1 to Z8 of Formula 1 is selected from the group consisting of a methyl group, an ethyl group, an n-propyl group, an iso-propyl group, an n-butyl group, a sec-butyl group, an iso-butyl group, a ter-butyl group, a pentyl group, a hexyl group, a styryl group, and an acetylene group.

7. The compound according to claim 1, wherein the aryl group of R1 to R13 of Formula 1 is selected from the group consisting of a phenyl group, a biphenyl group, a terphenyl group, a stilbene group, a naphthyl group, an anthracenyl group, a phenanthrene group, a pyrenyl group, and a perylenyl group.

8. The compound according to claim 1, wherein the arylamine group of R1 to R11 of Formula 1 is selected from the group consisting of a diphenylamine group, a dinaphthylamine group, a dibiphenylamine group, a phenylnaphthylamine group, a phenyldiphenylamine group, a ditolylamine group, a phenyltolylamine group, a carbazolyl group, and a triphenylamine group.

9. The compound according to claim 1, wherein the heterocyclic group of R1 to R13 of Formula 1 is selected from the group consisting of a thiophene group, a furan group, a pyrrole group, an imidazole group, a thiazole group, an oxazole group, an oxadiazole group, a triazole group, a pyridyl group, a pyradazine group, a quinolyl group, an isoquinoline group, and an acridyl group.

10. The compound according to claim 1, wherein the alkenyl, aryl, arylamine, and heterocyclic groups of R1 to R13 of Formula 1 are selected from the group consisting of the following Formulae:

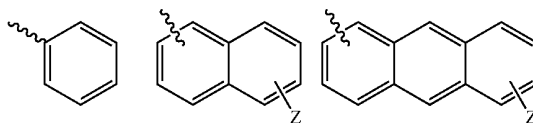

223

-continued

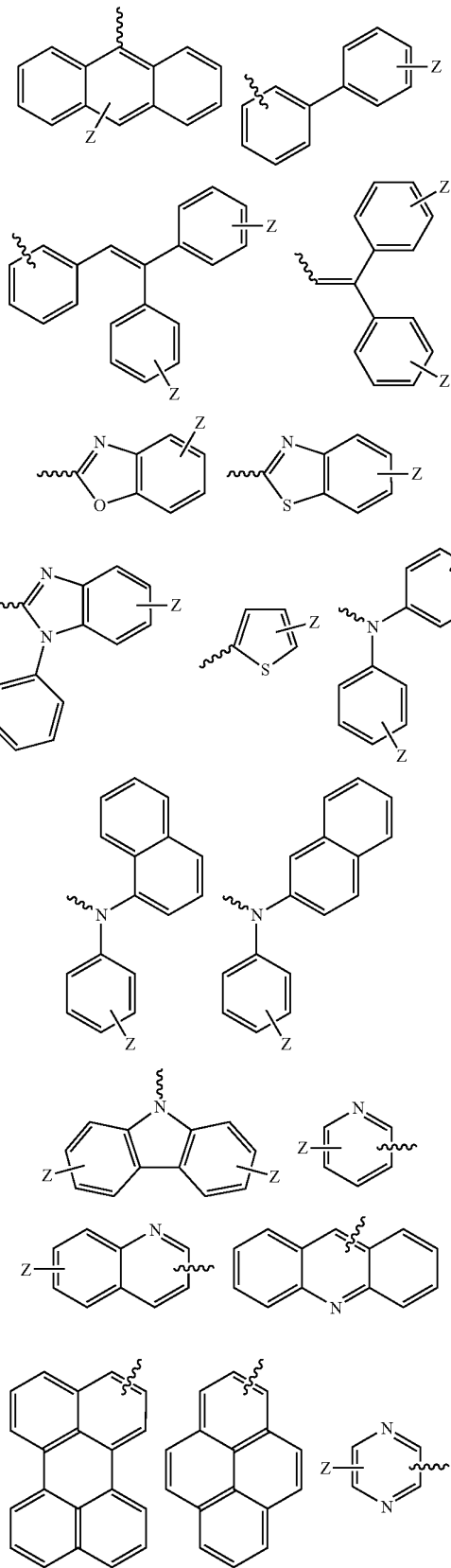

224

-continued

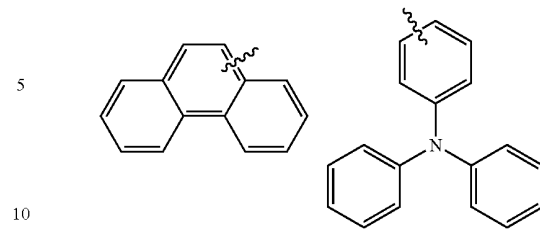

wherein Z is a group selected from the group consisting of hydrogen, aliphatic hydrocarbons having 1 to 20 carbon atoms, an alkoxy group, an arylamine group, an aryl group, a heterocyclic group, a nitrile group, and an acetylene group.

11. The compound according to claim 1, wherein Formula 1 is represented by any one of the following Formulae 2 to 7:

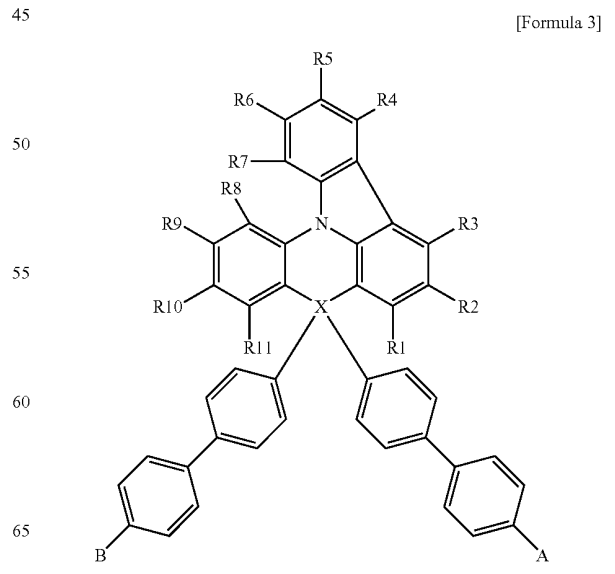
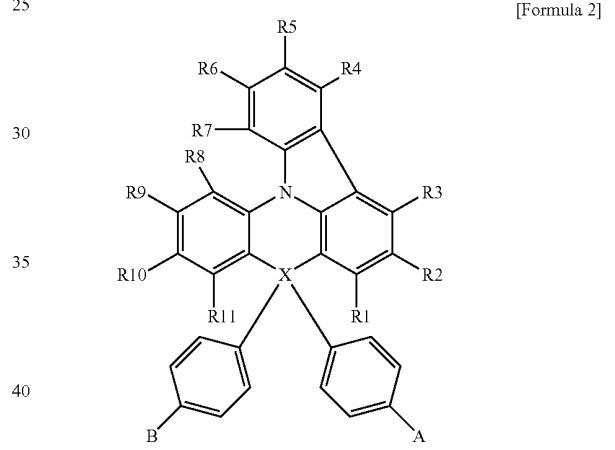

**225**  
-continued

**226**  
-continued

5

[Formula 4]

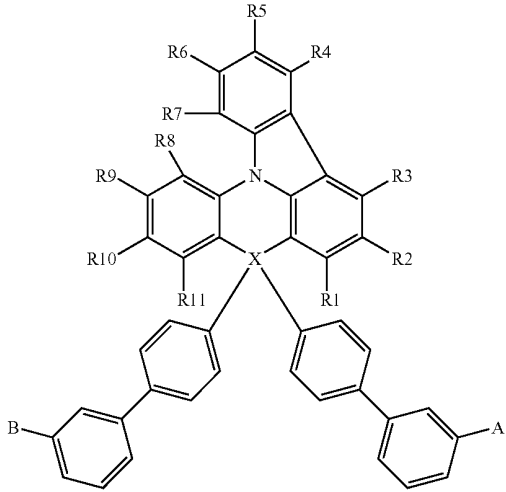

[Formula 6]

10

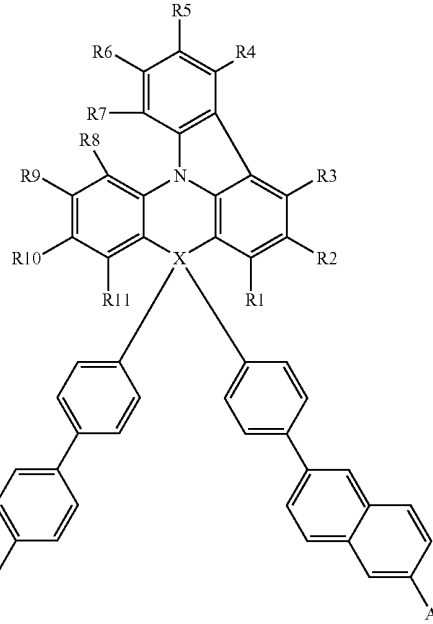

15

20

25

30

35

[Formula 7]

40

[Formula 5]

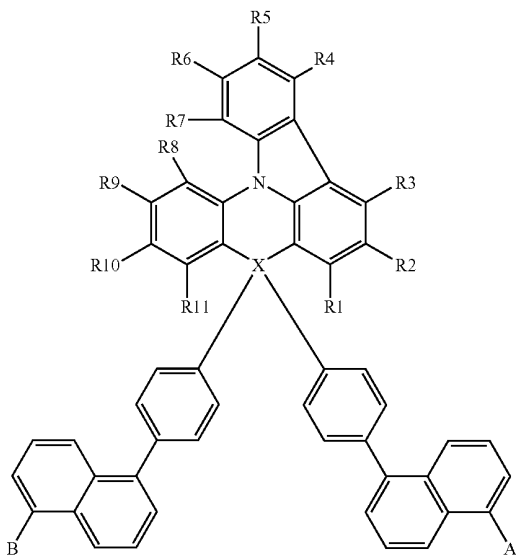

45

50

55

60

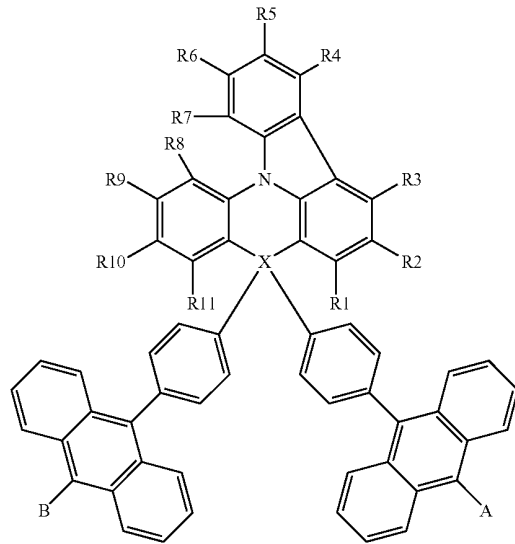

wherein X, R1 to R11, A, and B are as defined in Formula 1.

65

**12.** The compound according to claim 1, wherein A and B of Formula 1 are each independently selected from the group consisting of the following groups:

227

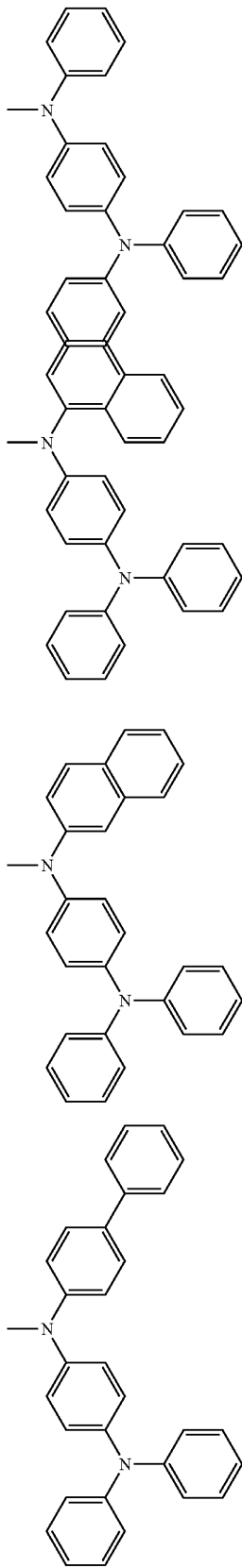

228

-continued

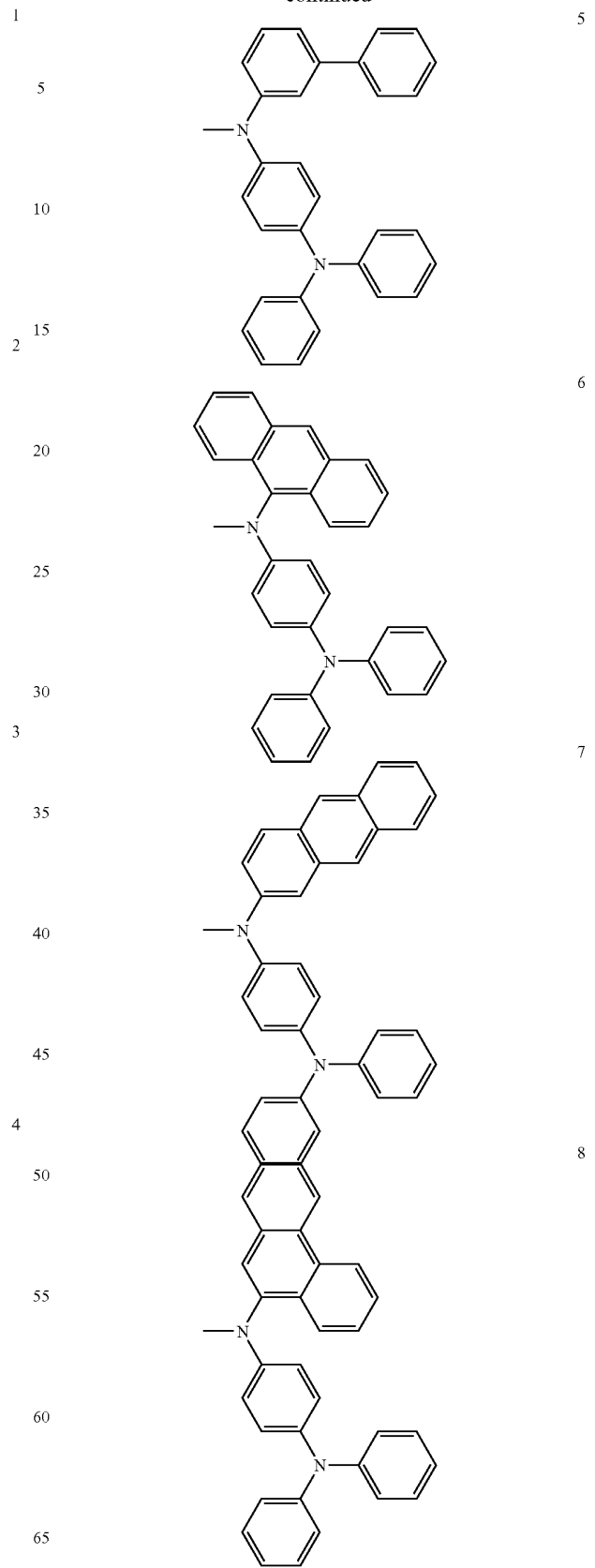

**229**

-continued

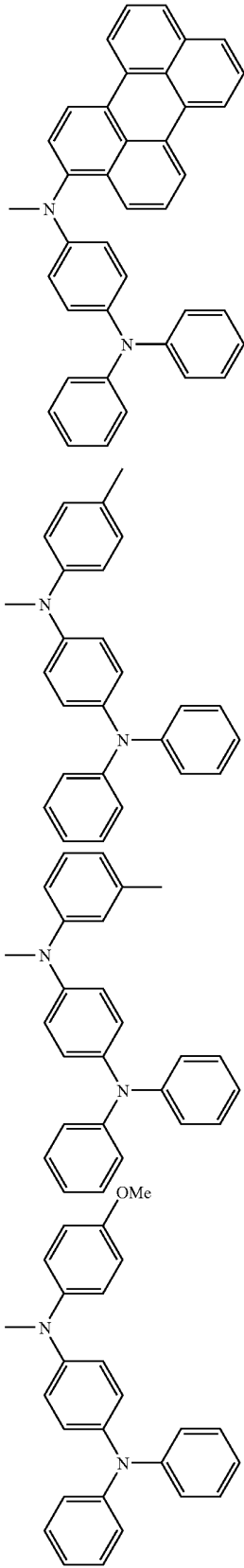

9

5

10

15

10  
20

25

30

11  
35

40

45

12  
50

55

60

65

**230**

-continued

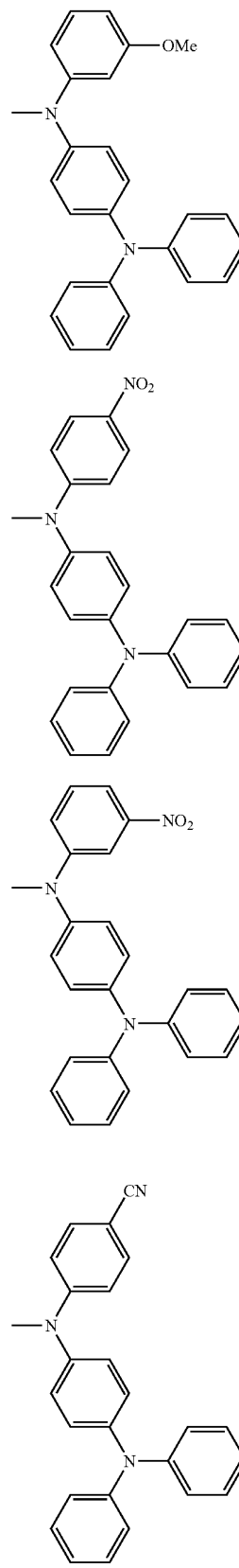

13

14

15

16

**231**

-continued

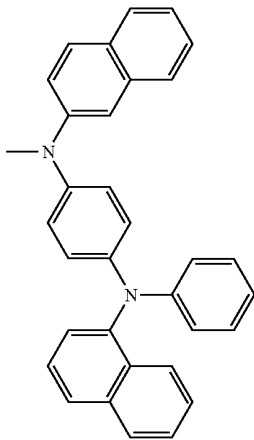
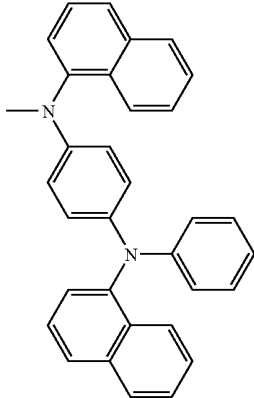
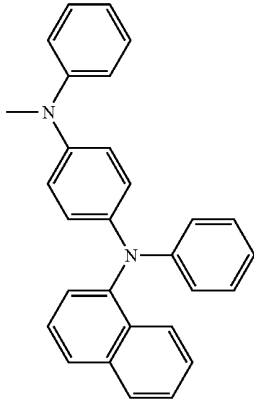
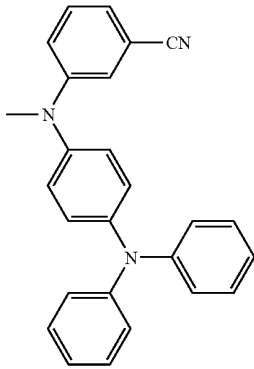

**232**

-continued

17

21

5

10

15

18

20

25

22

30

19

35

40

45

20

23

50

55

60

65

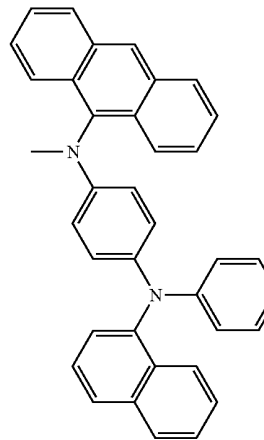
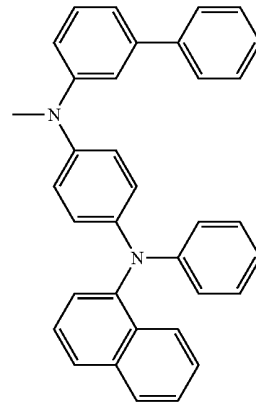
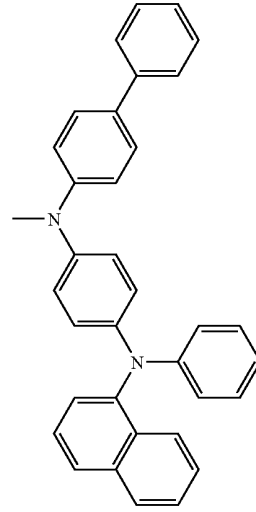

**233**

-continued

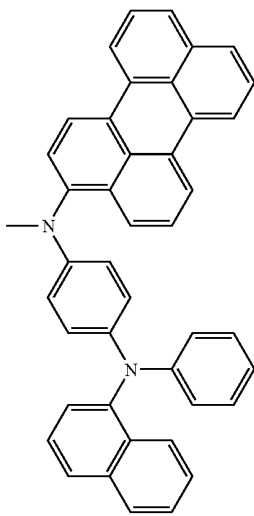
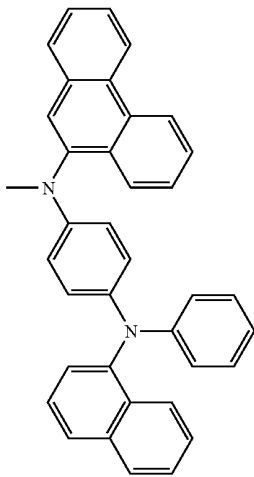
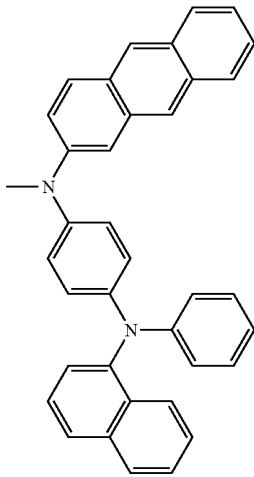

24

5

10

15

20

25

25

30

35

40

45

26

50

55

60

65

**234**

-continued

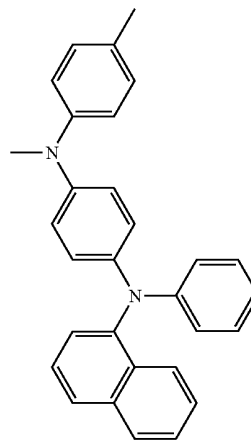

27

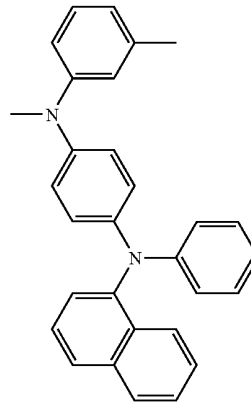

28

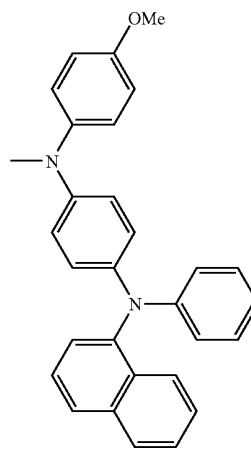

29

**235**

-continued

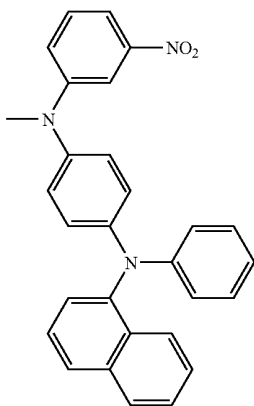
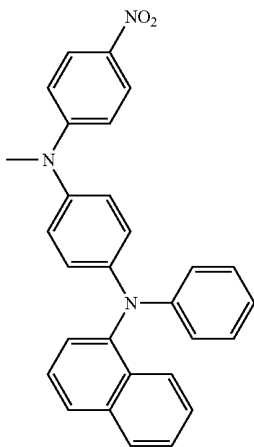
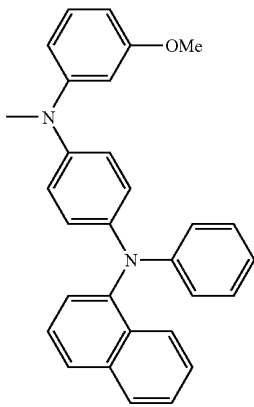

**236**

-continued

5  
30

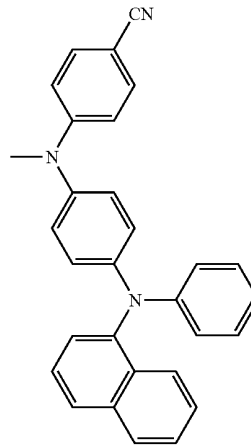

33

10

15

20

25

31

30

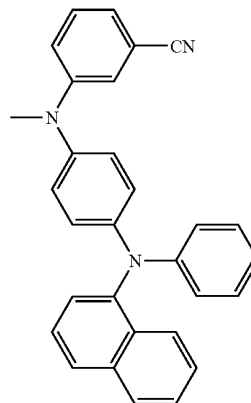

34

35

40

45

32  
50

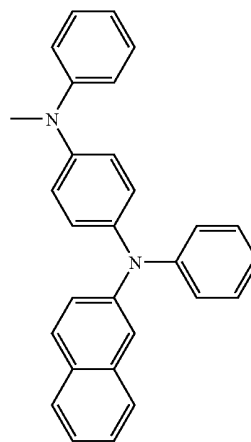

35

55

60

65

**21**  
-continued

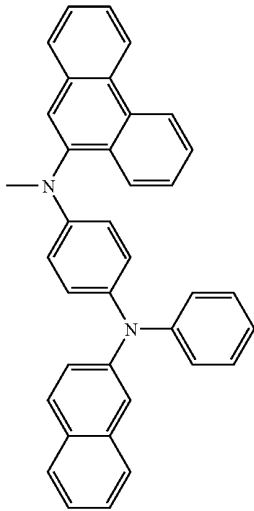
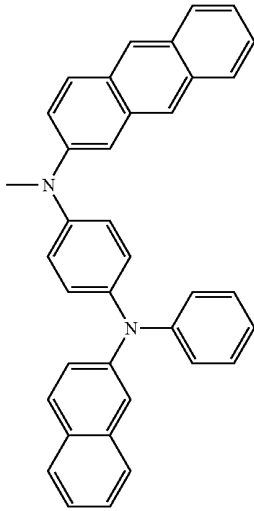
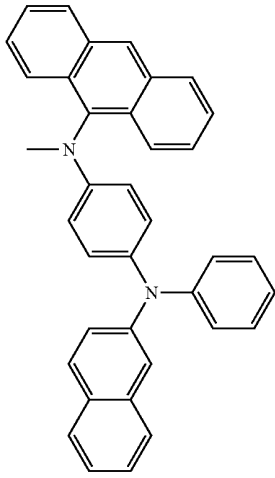

**22**  
-continued

40

43

5

10

15

20

41

25

30

35

40

45

42

50

55

60

65

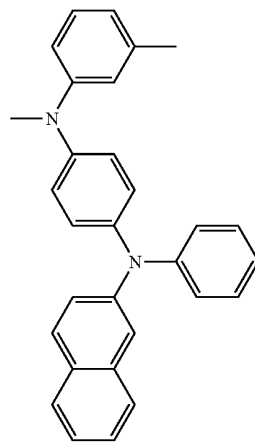
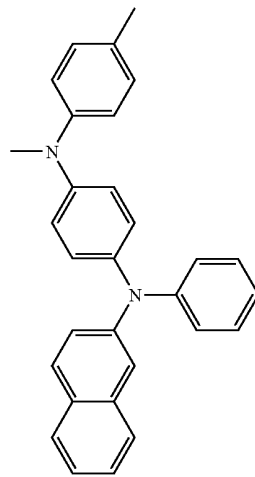
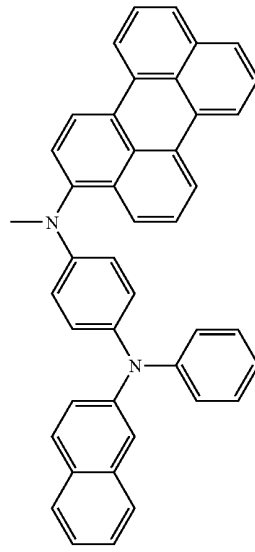

237

-continued

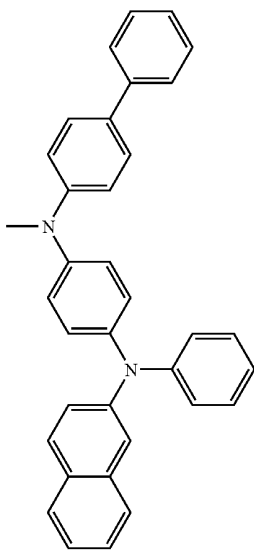
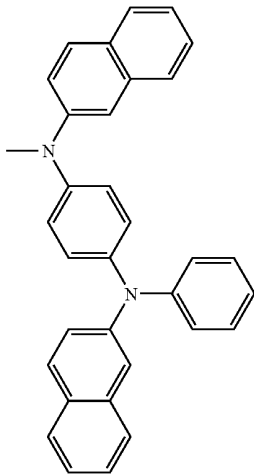
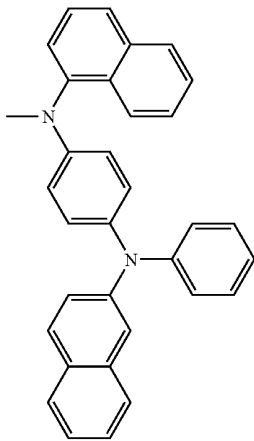

238

-continued

36

5

10

15

20

37

25

30

35

40

38 45

50

55

60

65

39

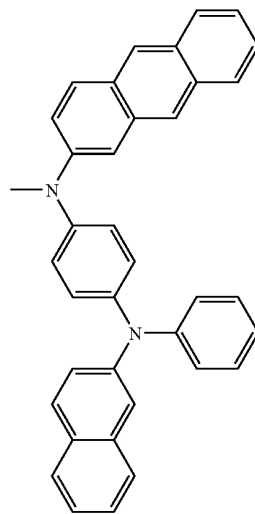
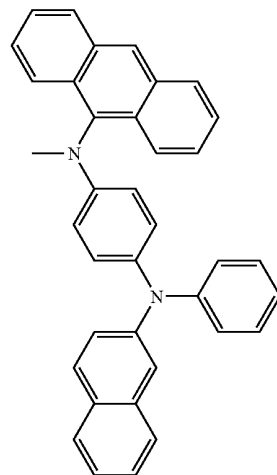
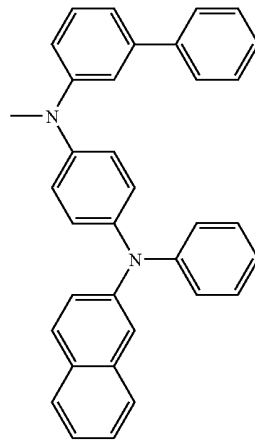

40

41

239

-continued

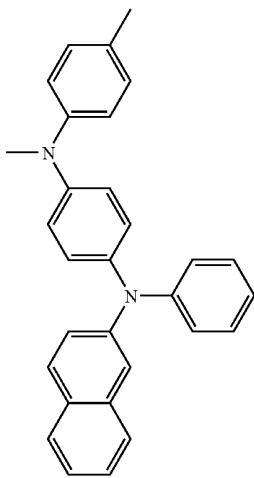
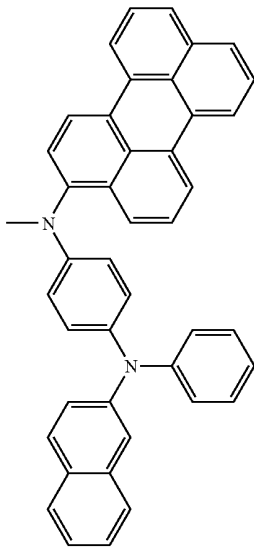
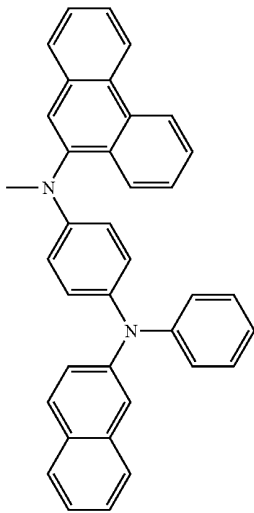

240

-continued

42

5

10

15

20

43

25

30

35

40

45

44

50

55

60

65

45

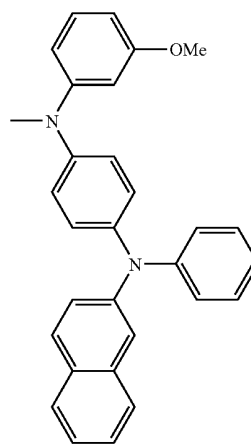
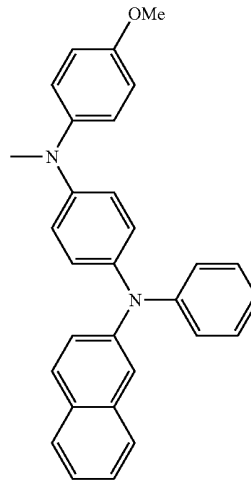
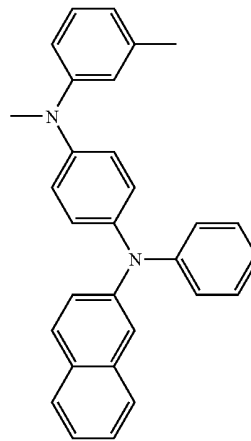

46

47

**241**

-continued

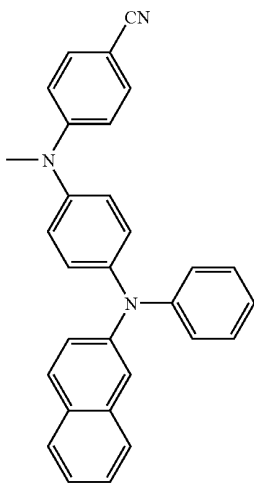
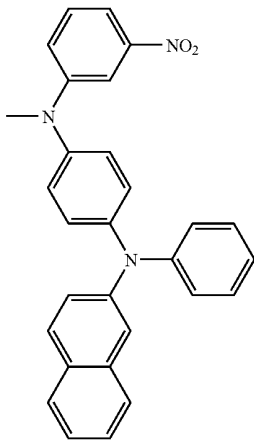
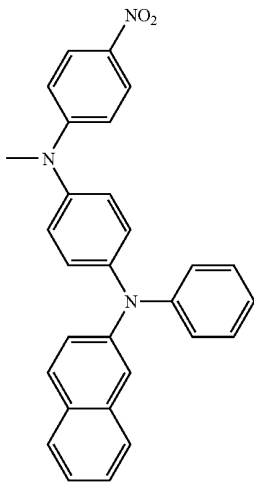

**242**

-continued

48

51

5

10

15

20

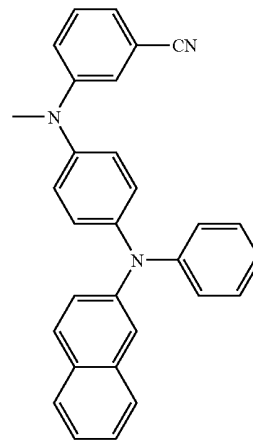

49

52

25

30

35

40

45

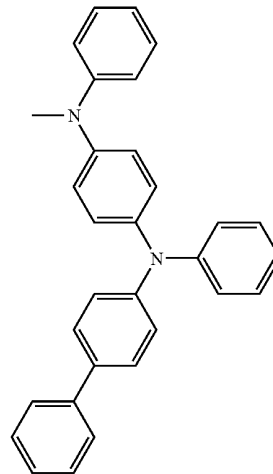

50

53

50

55

60

65

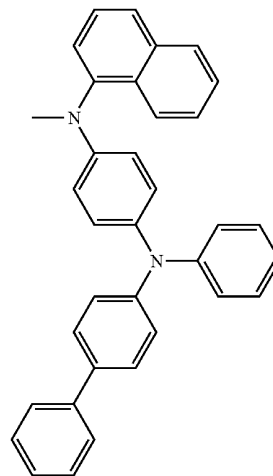

243

-continued

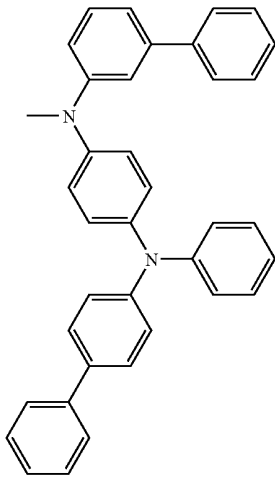
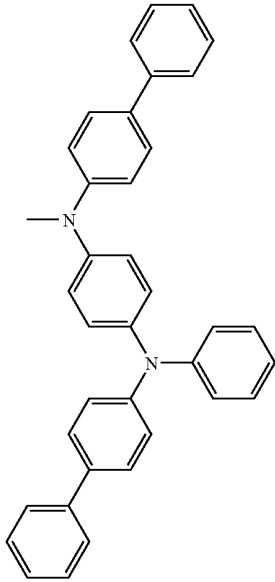
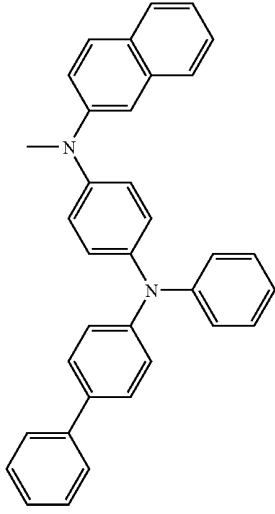

54

244

-continued

5

10

15

20

55

25

30

35

40

45

56

50

55

60

65

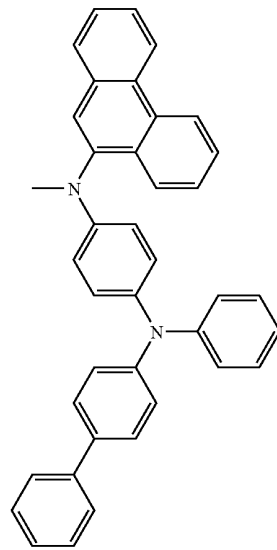
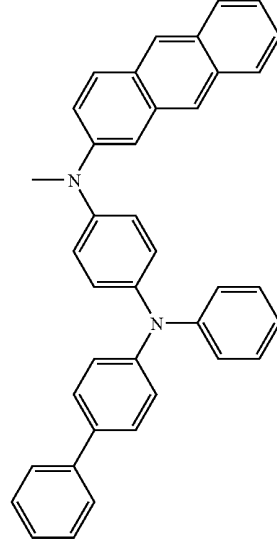
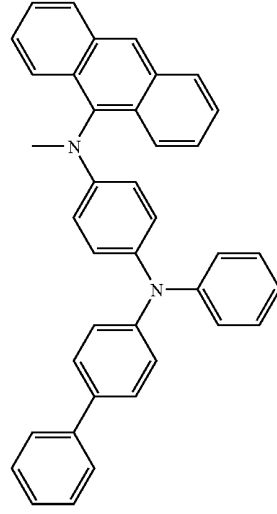

57

58

59

245

-continued

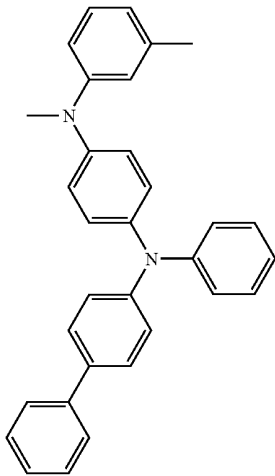
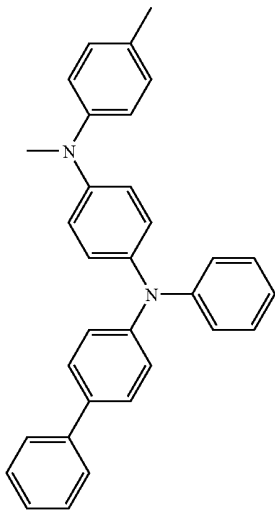
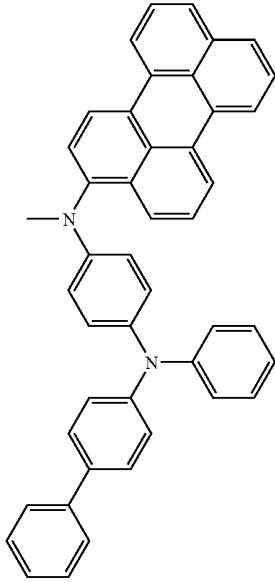

246

-continued

60

63

5

10

15

20

25

61

30

35

40

45

62

50

55

60

65

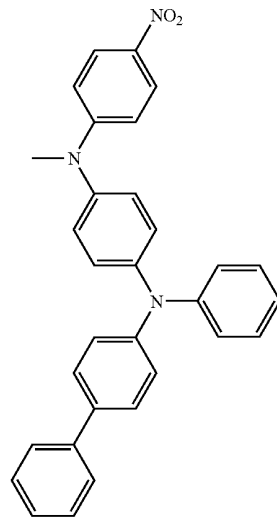
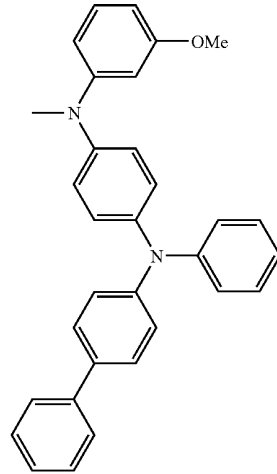
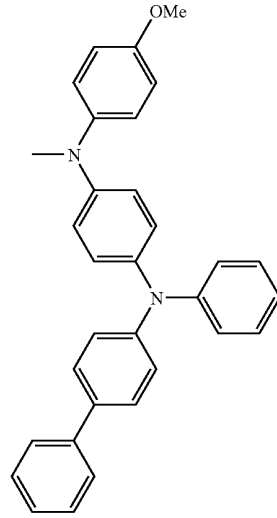

247

-continued

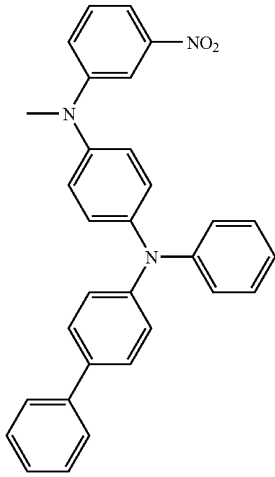

66

5

10

15

20

248

-continued

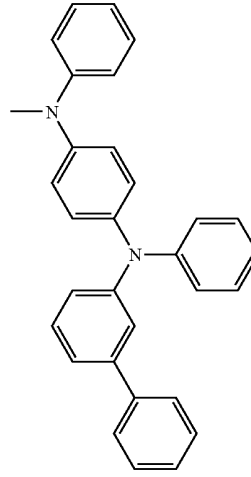

69

67

25

30

35

40

45

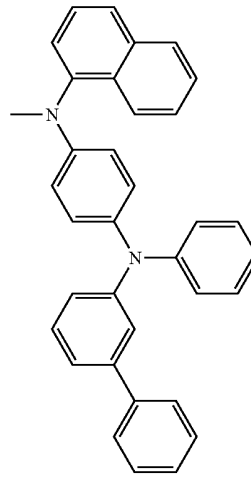

70

68

50

55

60

65

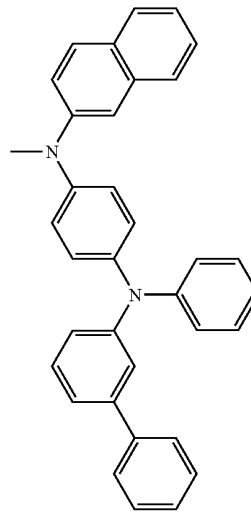

71

249

-continued

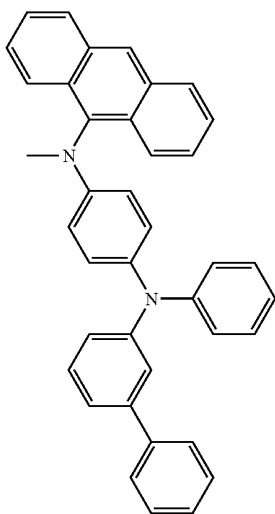
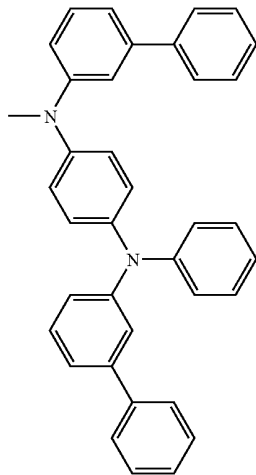
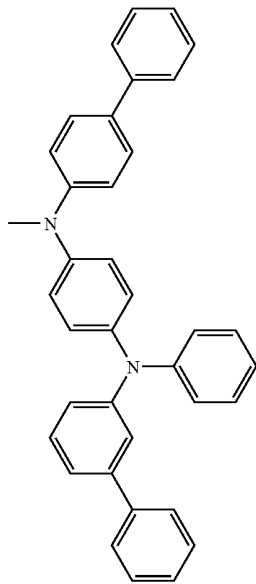

250

-continued

72

5

10

15

20

25  
73

30

35

40

45  
74

50

55

60

65

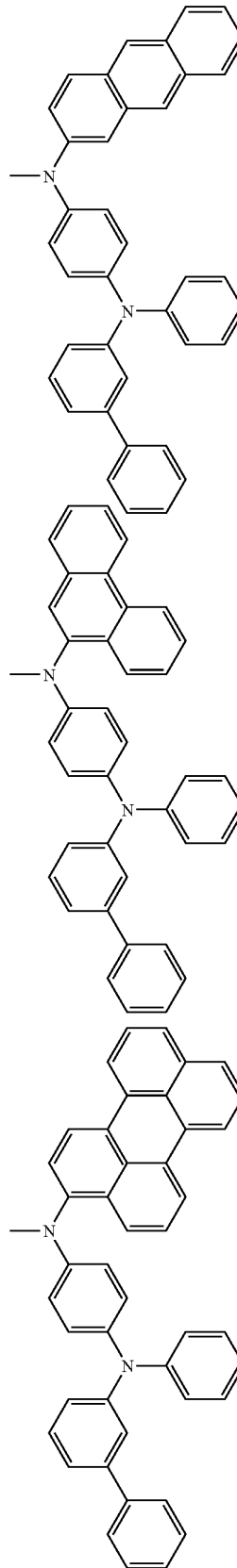

75

76

77

251

-continued

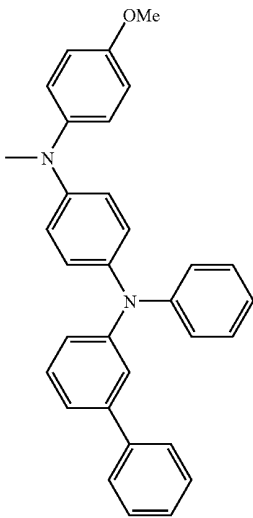
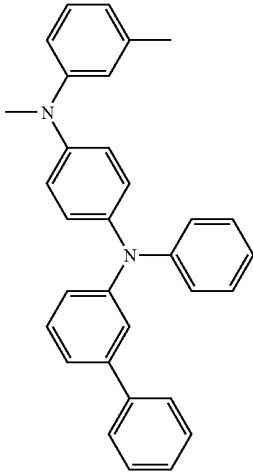
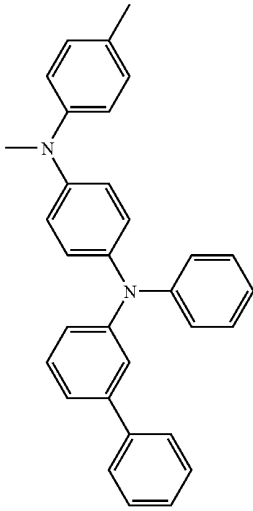

252

-continued

78

5

10

15

20

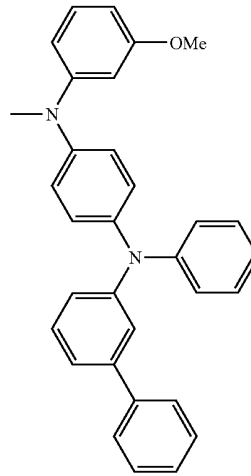

81

79

25

30

35

40

45

80

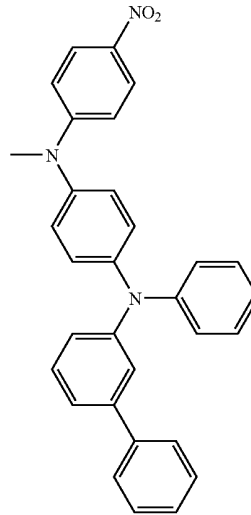

82

50

55

60

65

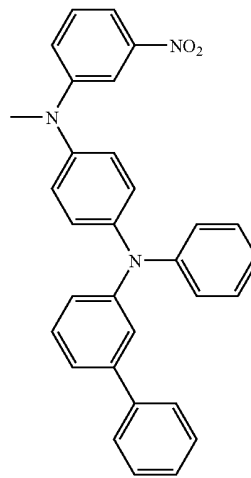

83

**253**  
-continued

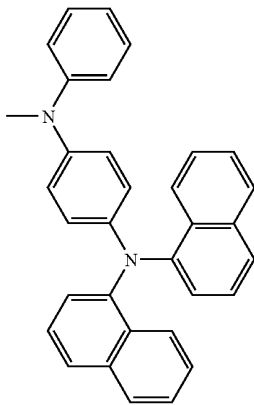
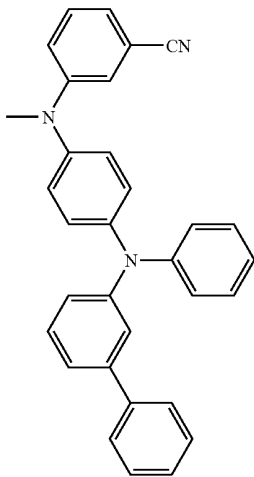
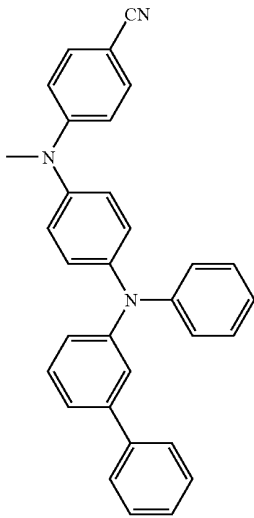

**254**  
-continued

84  
5

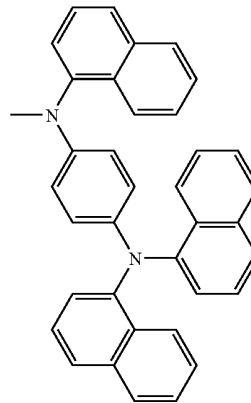

87

10

15

20

25

85

30

35

40

45

86  
50

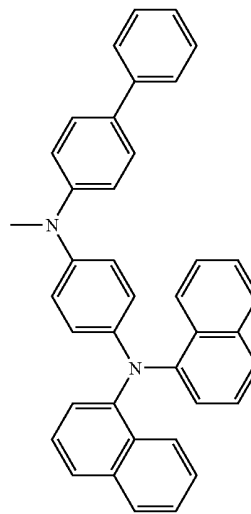

88

55

60

65

89

**255**  
-continued

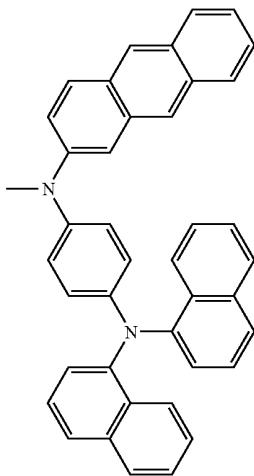
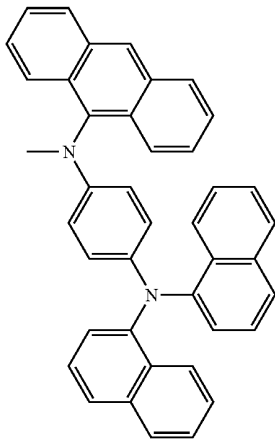
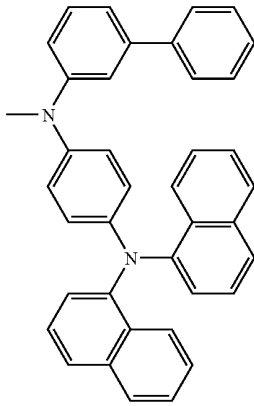

**256**  
-continued

90  
5

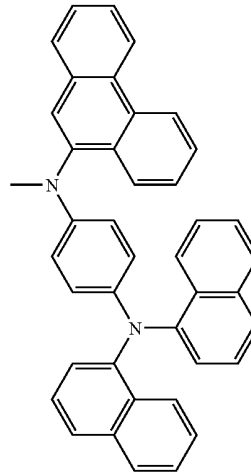

93

91  
25

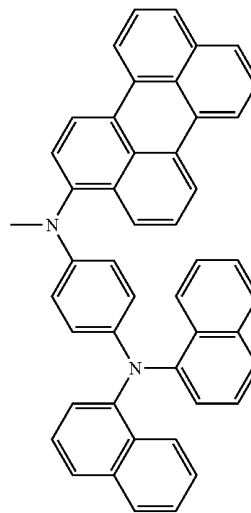

94

92

50

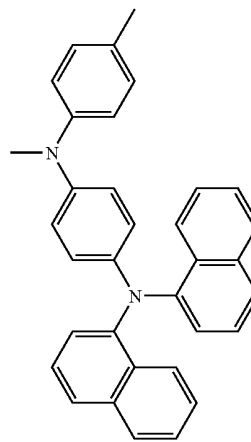

95

55

60

65

**23**  
-continued

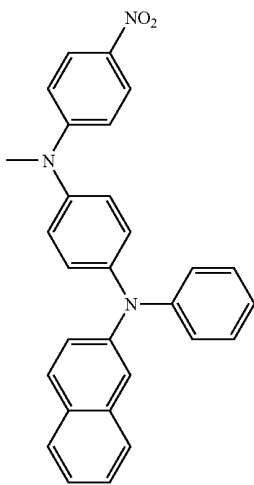
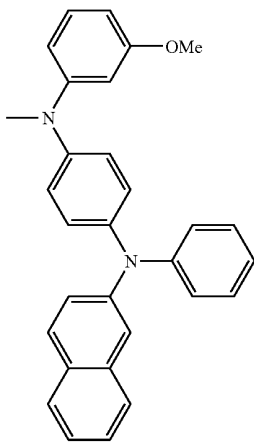
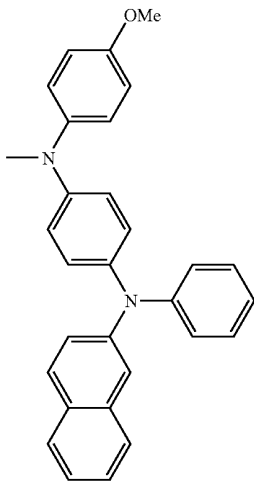

**24**  
-continued

46 5

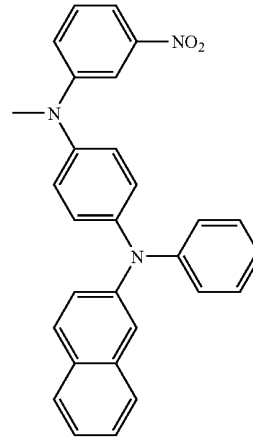

49

10

15

20

25

47

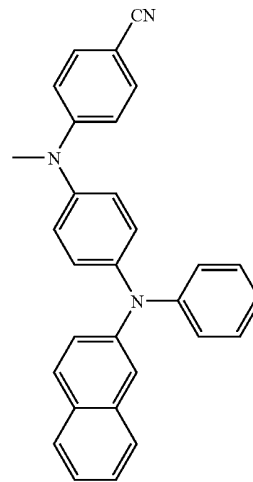

50

30

35

40

45

48

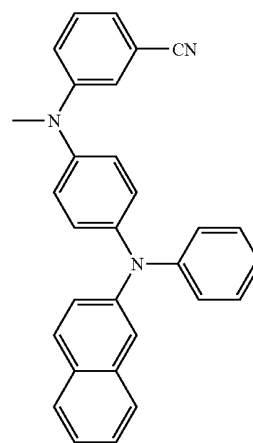

51

50

55

60

65

257

-continued

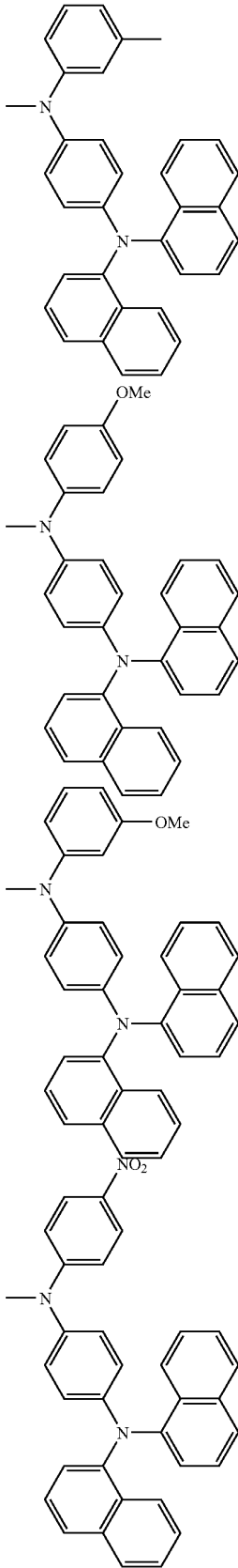

258

-continued

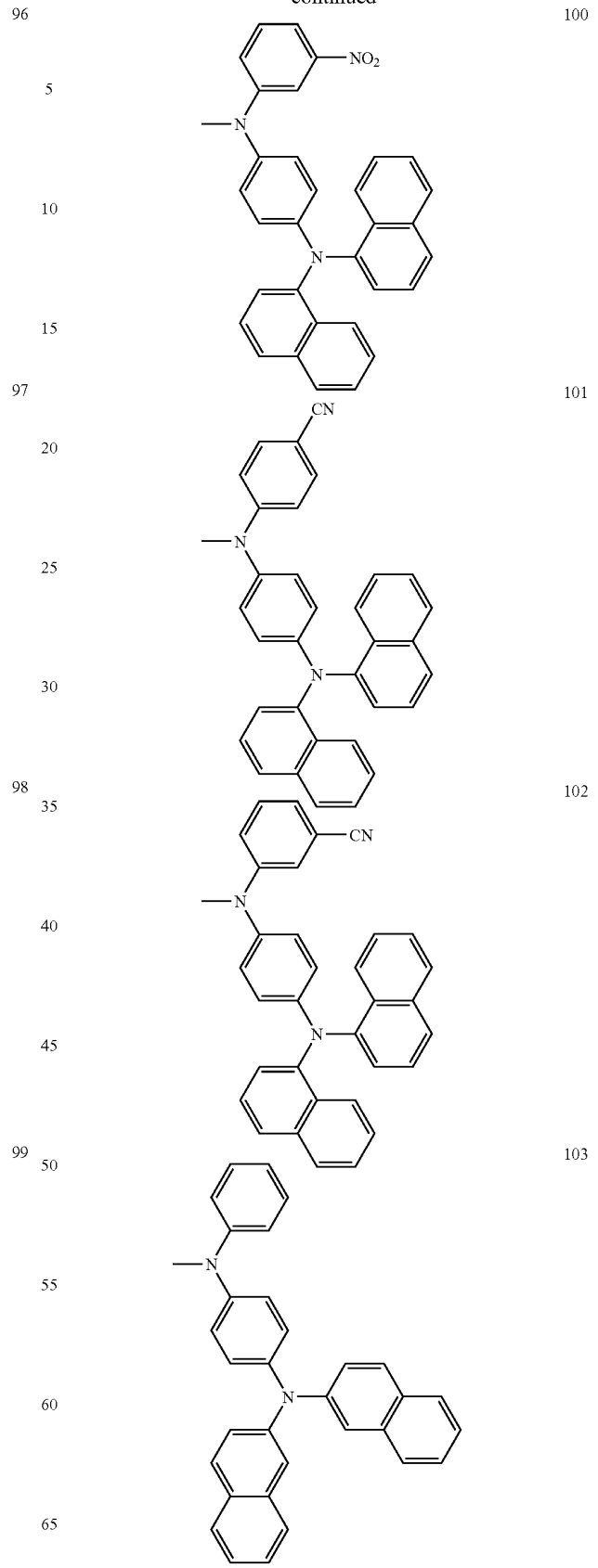

**259**  
-continued

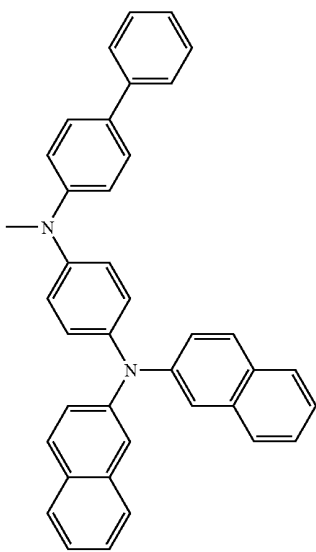
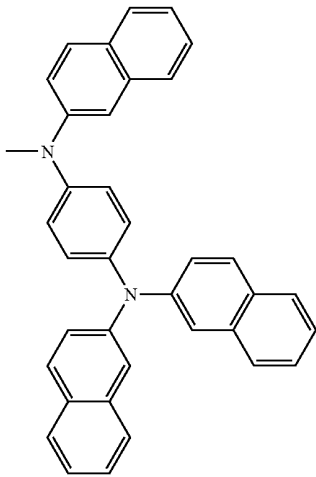
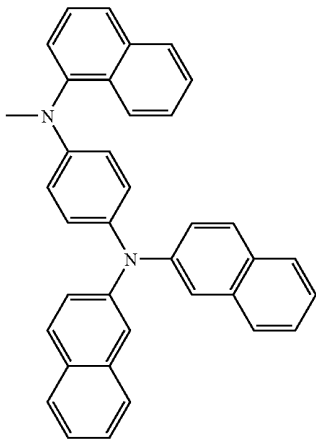

**260**  
-continued

104

107

5

10

15

20

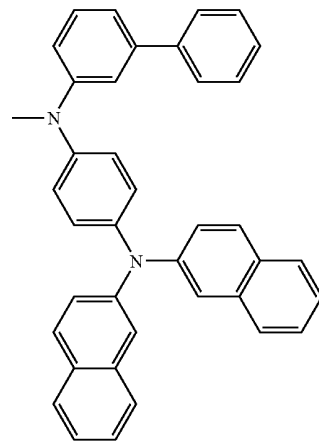

105

108

25

30

35

40

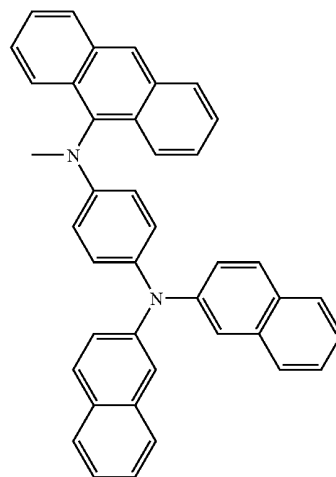

106 45

109

50

55

60

65

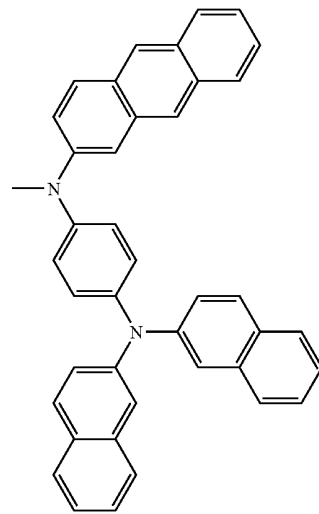

261

-continued

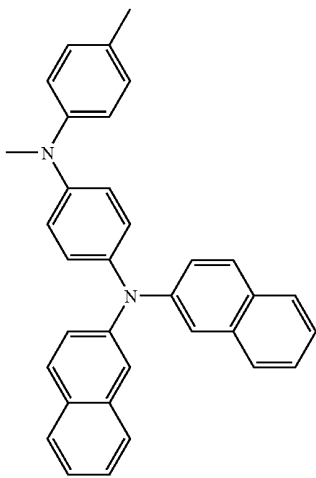
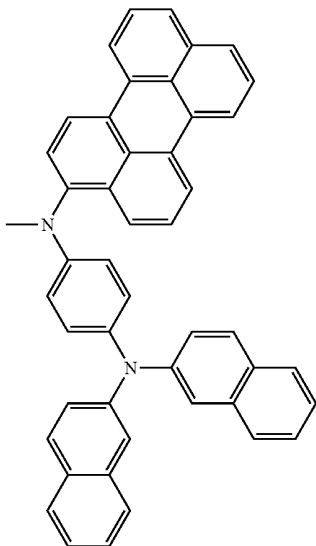
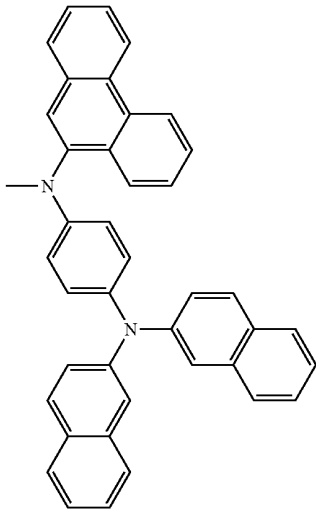

262

-continued

110

113

5

10

15

20

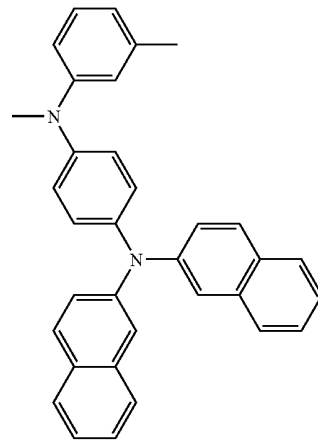

111

114

25

30

35

40

45

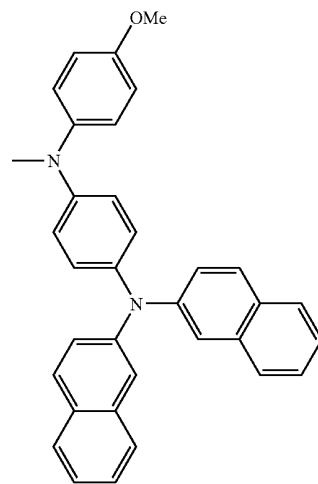

112

115

50

55

60

65

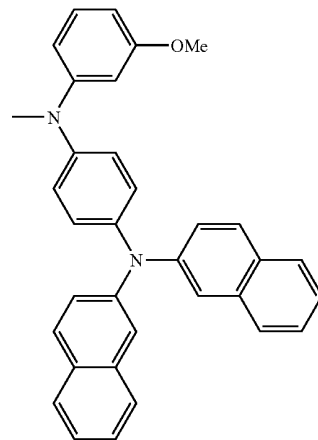

**263**  
-continued

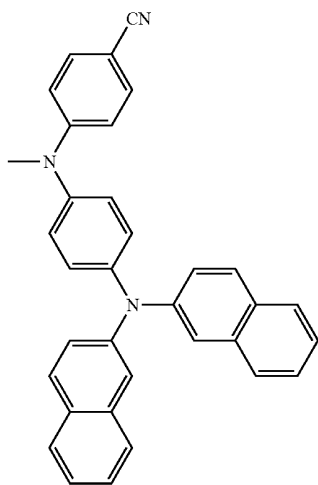
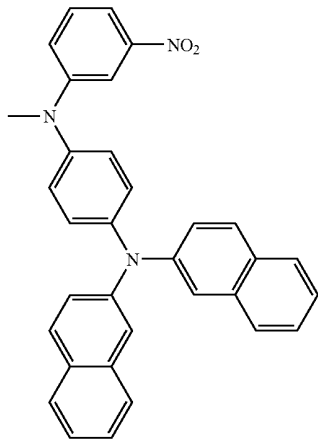
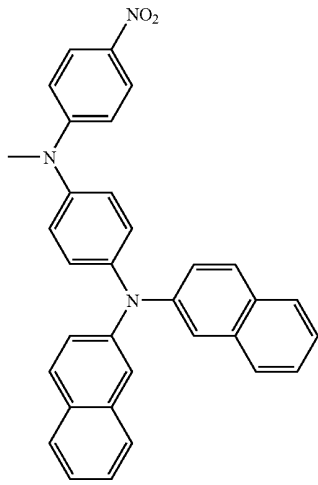

**264**  
-continued

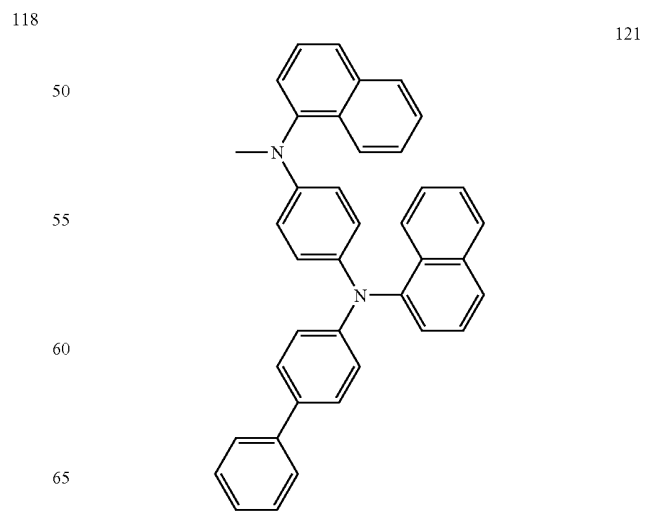
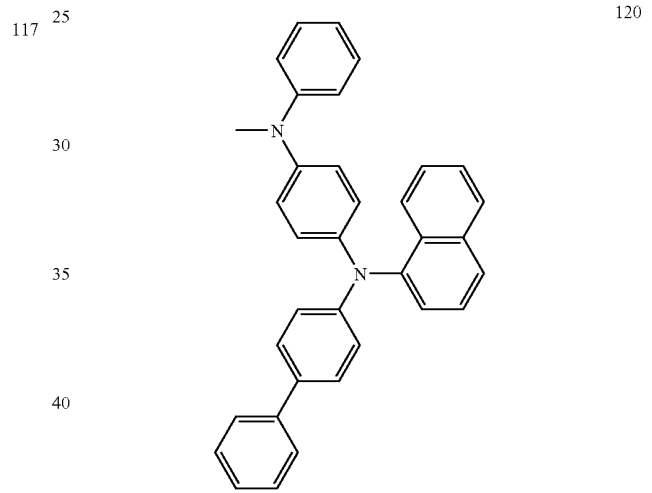
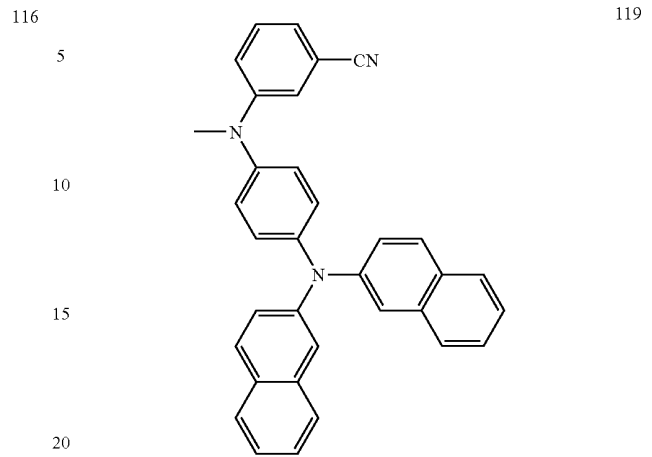

**265**

-continued

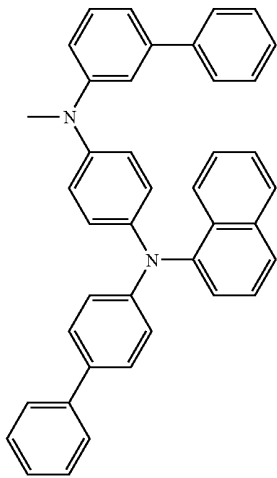
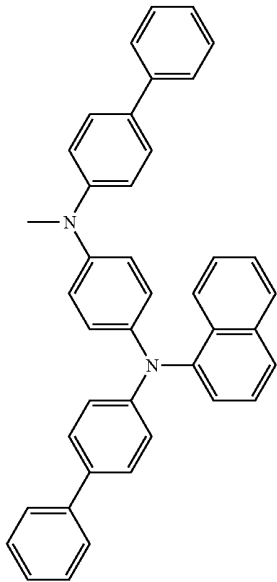
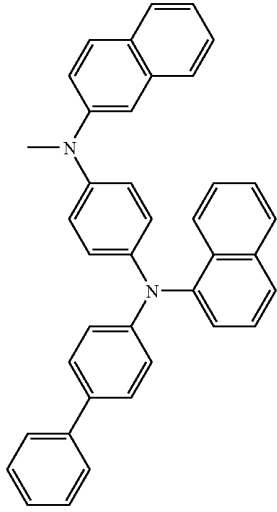

**266**

-continued

122

125

5

10

15

20

123

25

30

35

40

45

126

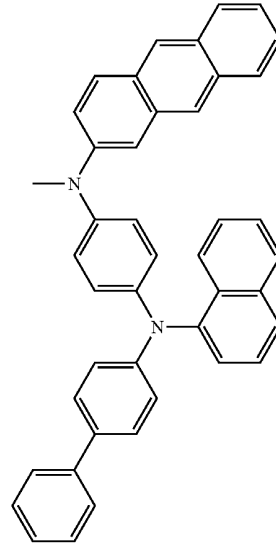
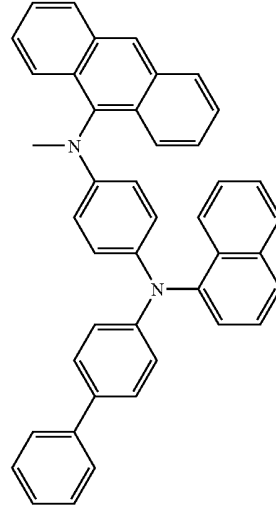

124

50

55

60

65

127

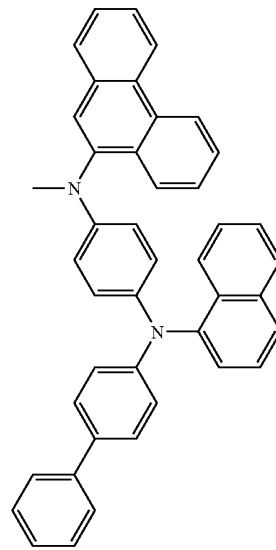

267

-continued

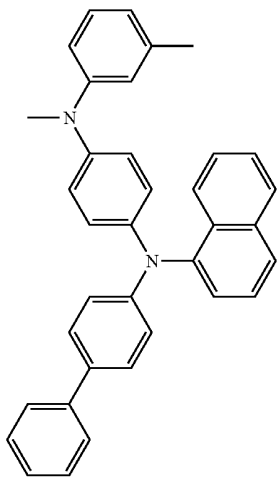
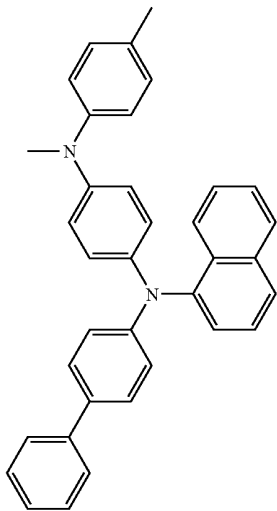
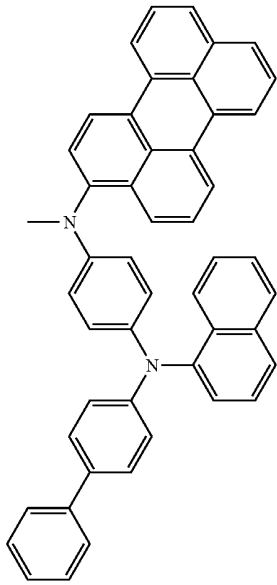

268

-continued

128

131

5

10

15

20

129

25

30

35

40

45

132

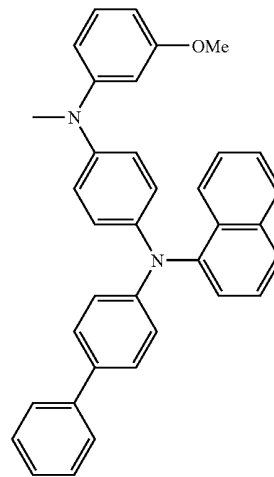
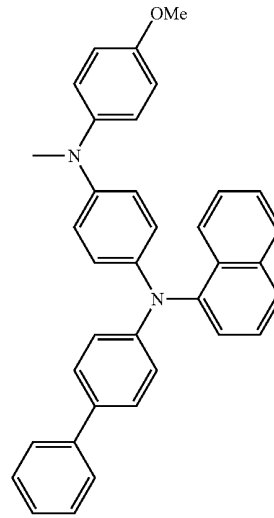

130

50

55

60

65

133

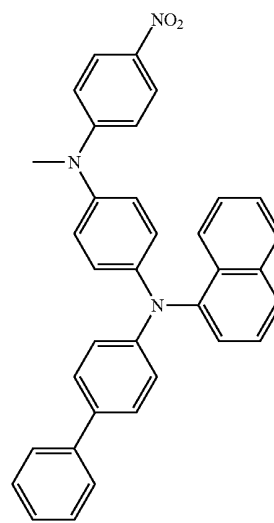

269

-continued

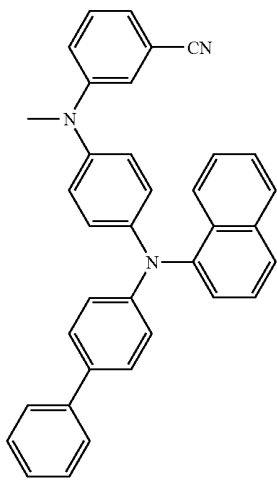
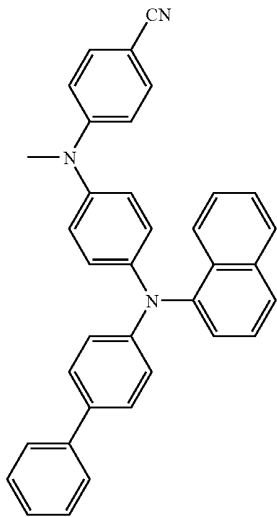
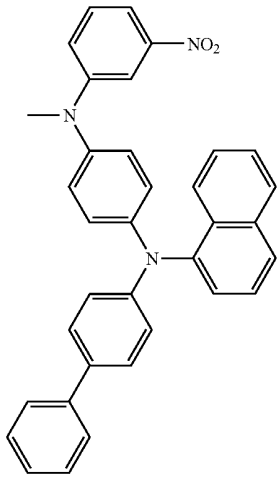

270

-continued

134

5

10

15

20

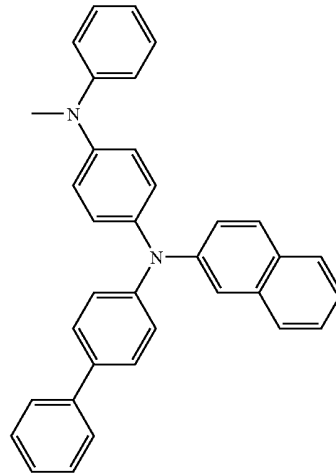

137

135

25

30

35

40

45

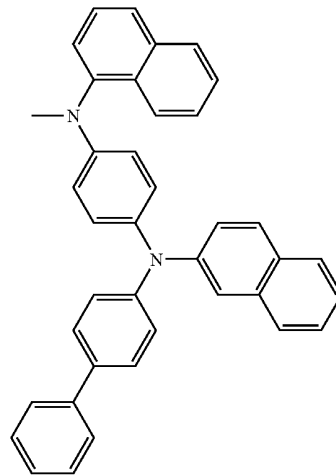

138

136

50

55

60

65

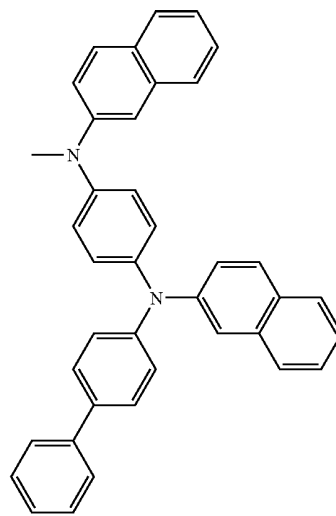

139

271

-continued

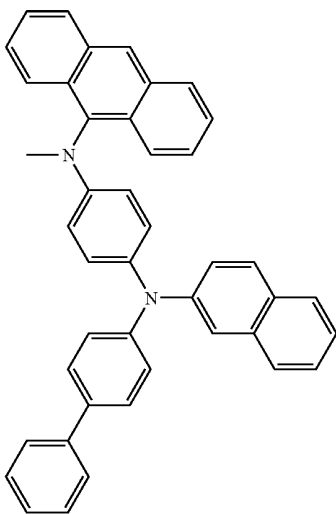
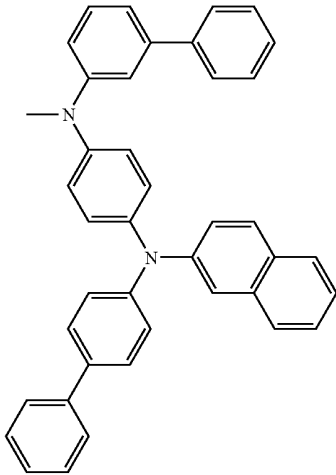
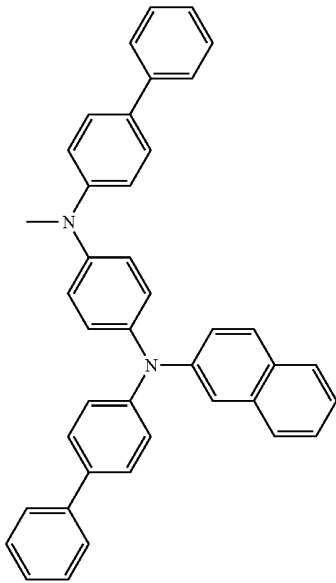

272

-continued

140

5

143

10

15

20

25

141

30

35

40

45

142

50

55

60

65

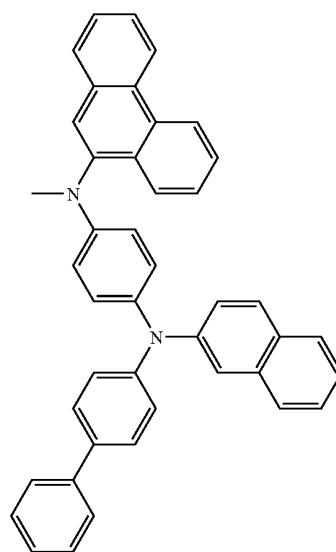
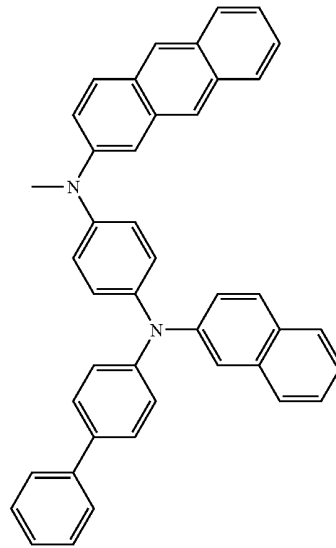

273

-continued

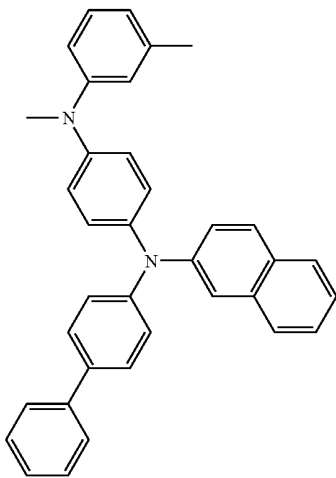
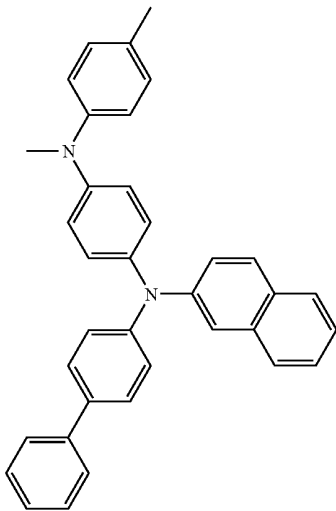
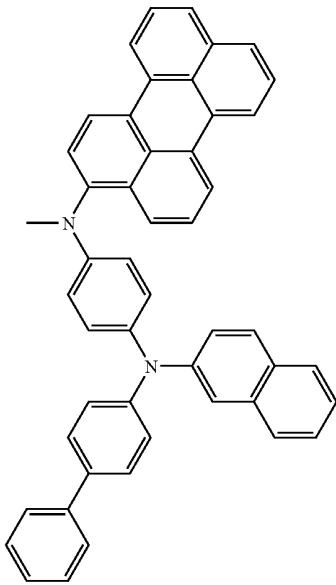

274

-continued

145

148

5

10

15

20

25

146

149

30

35

40

45

147

150

50

55

60

65

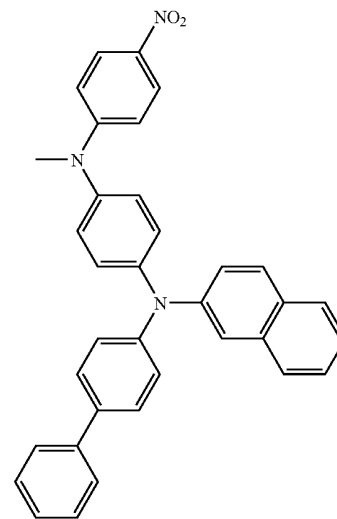
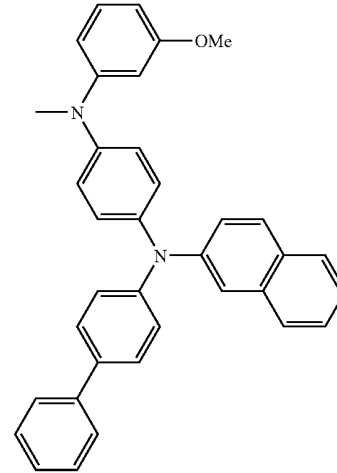
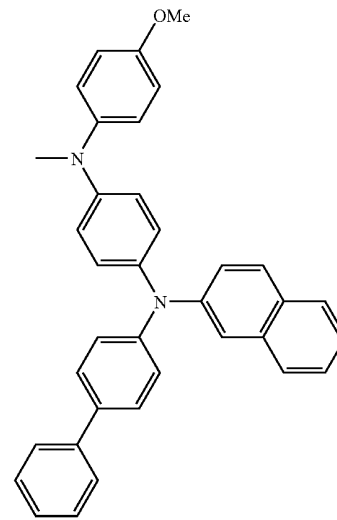

**275**  
-continued

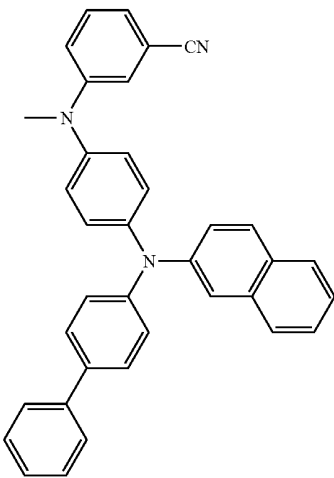
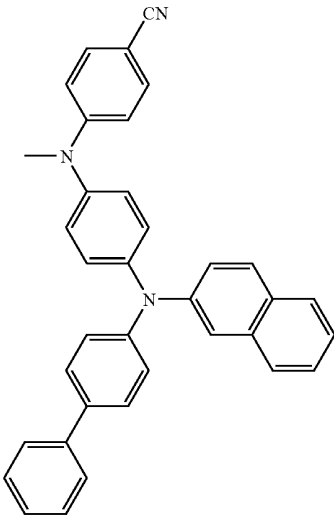
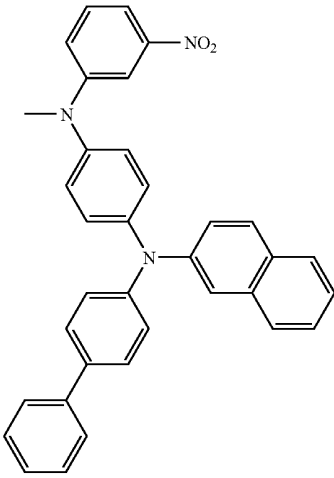

**276**  
-continued

151  
5  
10  
15  
20

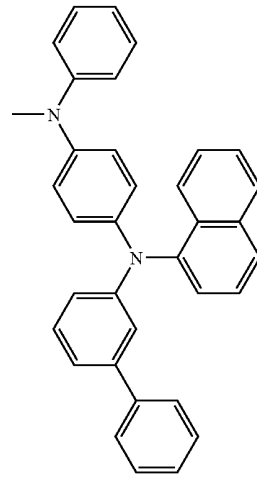

154

152 25  
30  
35  
40  
45

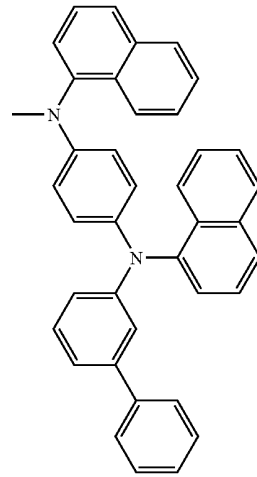

155

153  
50  
55  
60  
65

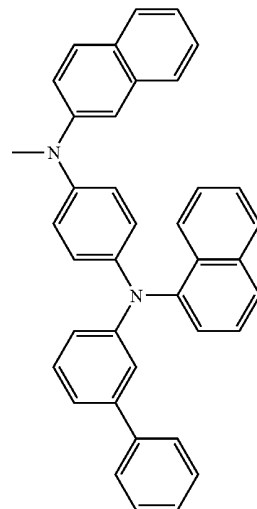

156

25

-continued

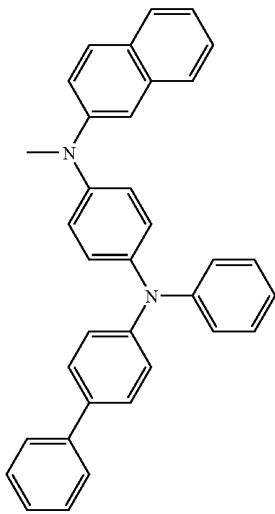
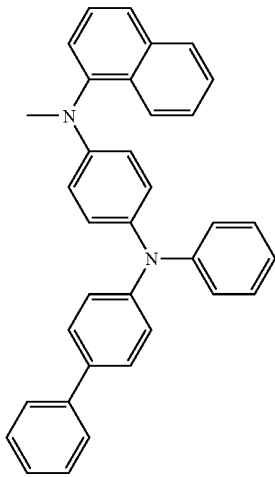
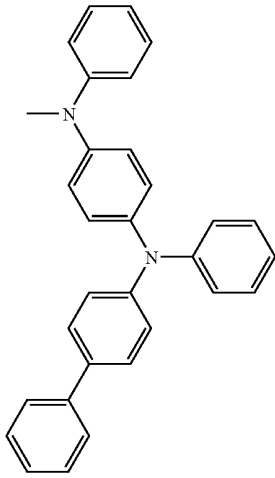

26

-continued

52

5

10

15

20

25

53

30

35

40

45

54

50

55

60

65

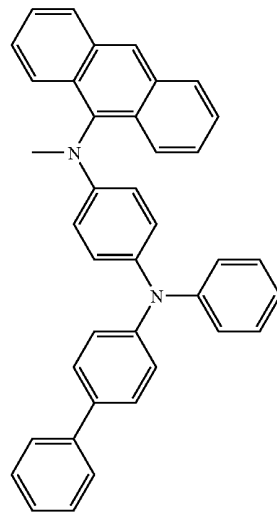
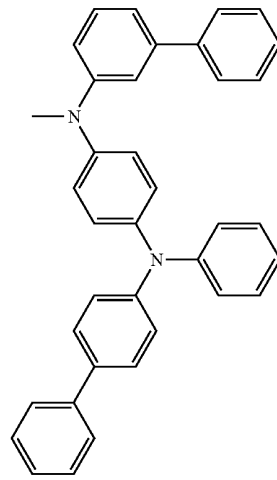
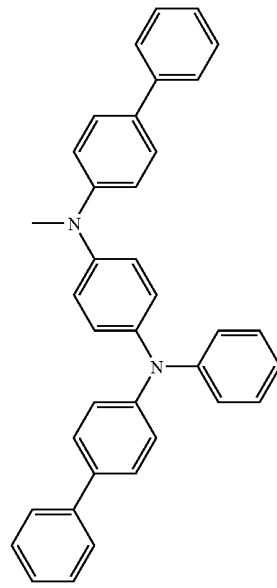

55

56

57

**277**  
-continued

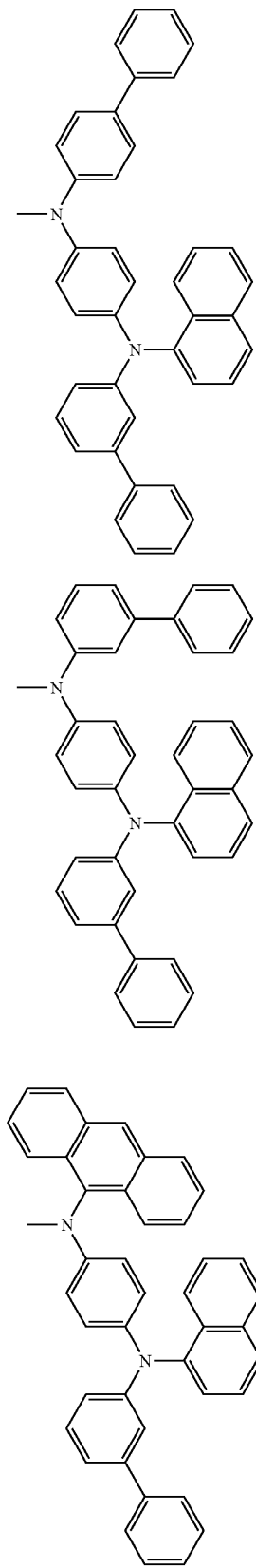

**278**  
-continued

157

5

10

15

20

158 25

30

35

40

159 45

50

55

60

65

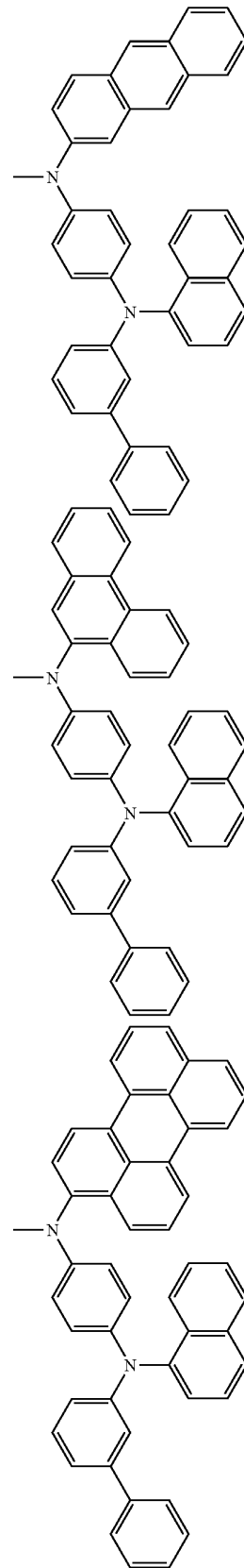

160

161

162

279

-continued

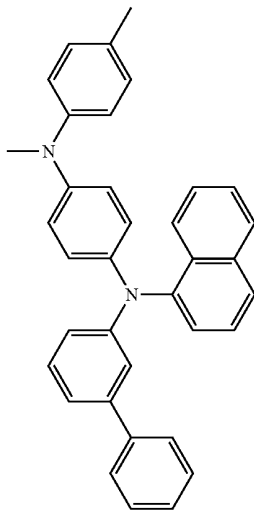

163

280

-continued

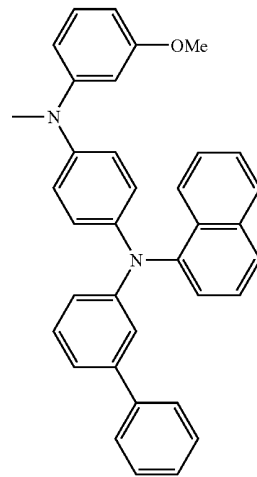

166

5

10

15

20

164

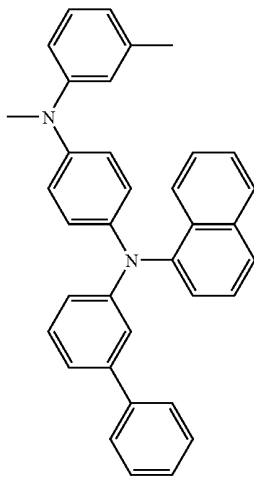

167

25

30

35

40

45

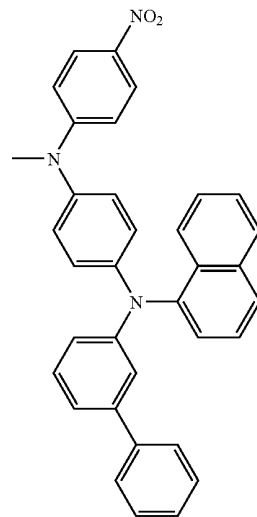

165

168

50

55

60

65

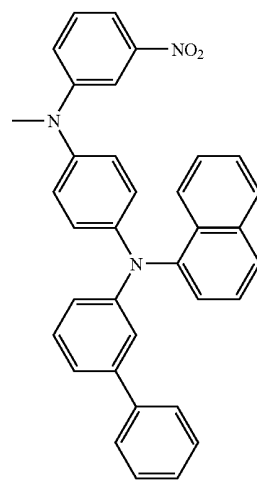
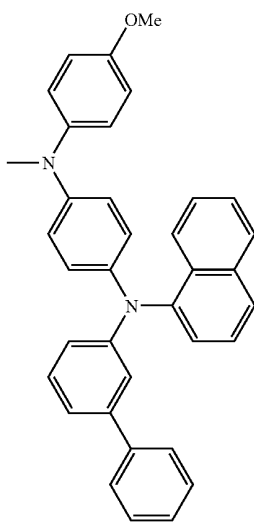

**281**

-continued

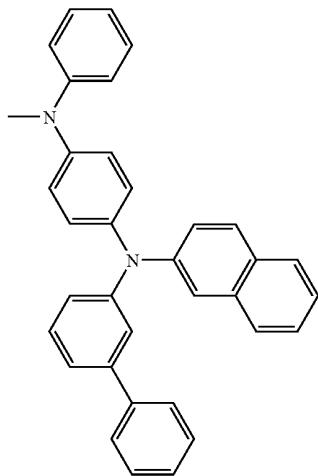
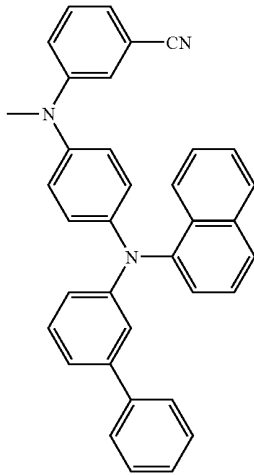
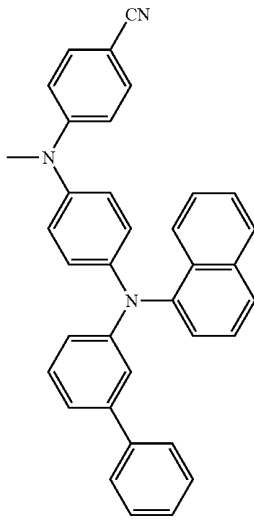

**282**

-continued

169

172

5

10

15

20

170

25

30

35

40

45

171

50

55

60

65

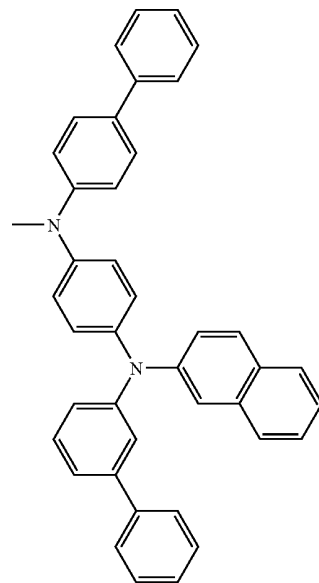
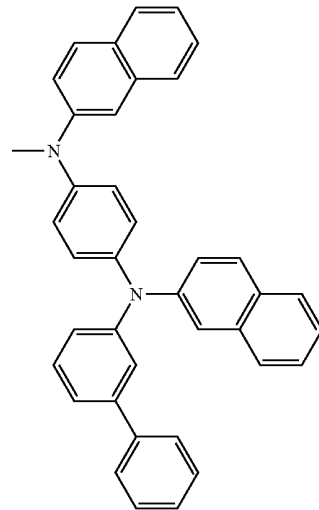
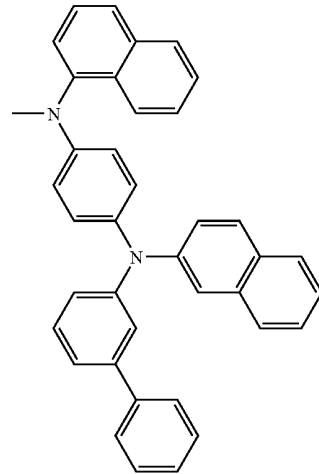

173

174

**283**

-continued

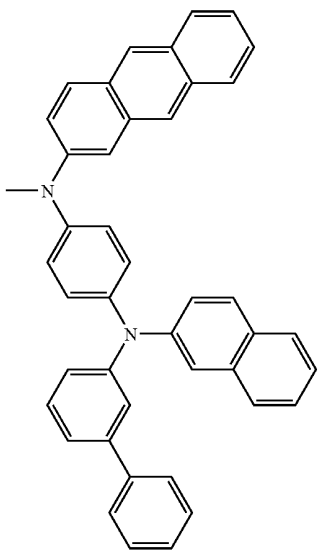
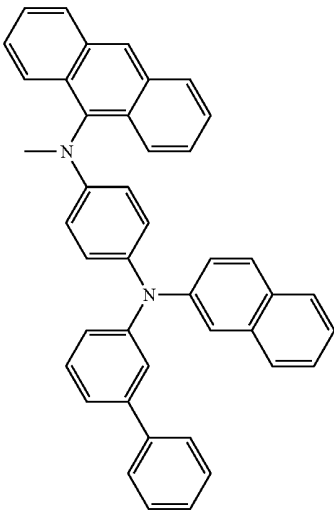
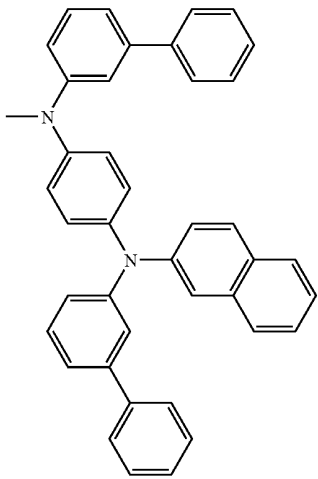

**284**

-continued

175

5

10

15

20

176

25

30

35

40

177 45

50

55

60

65

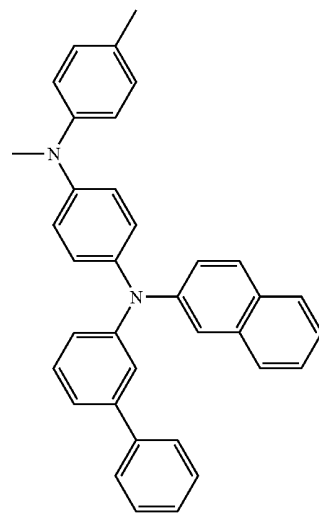
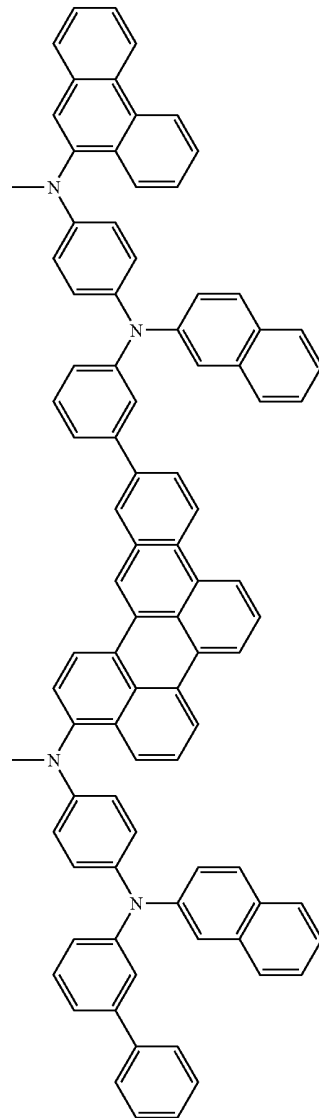

178

179

180

**285**  
-continued

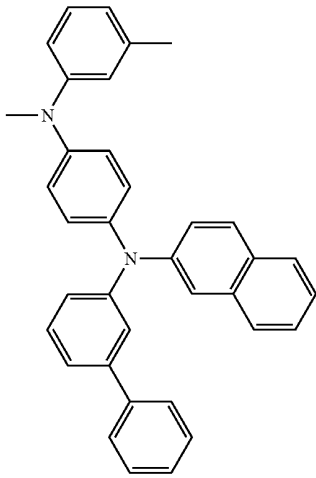

181

5

10

15

20

182

25

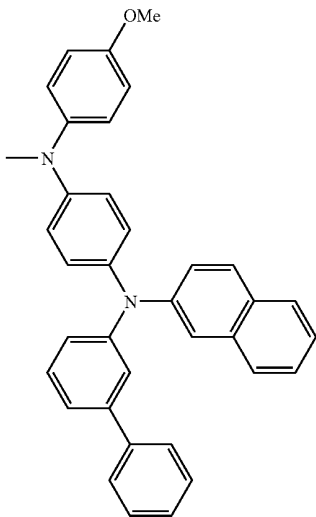

30

35

40

45

183

50

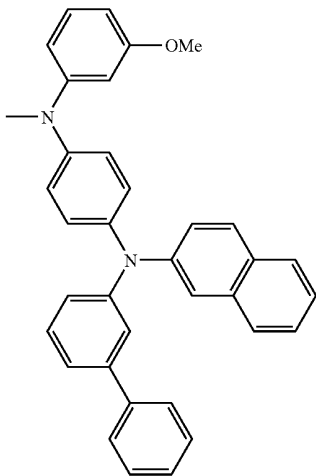

55

60

65

**286**  
-continued

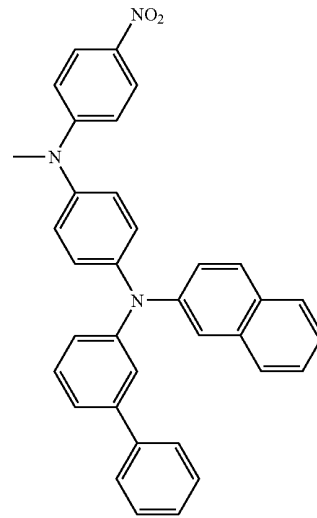

184

5

10

15

20

182

25

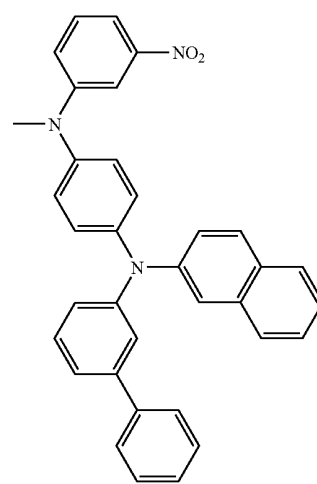

185

30

35

40

45

183

50

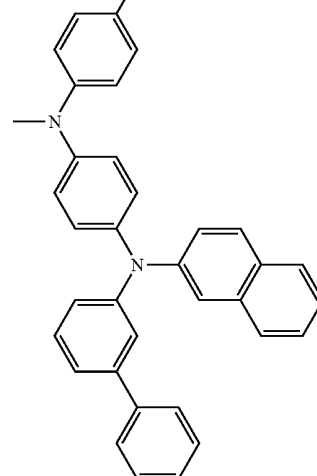

186

55

60

65

**287**  
-continued

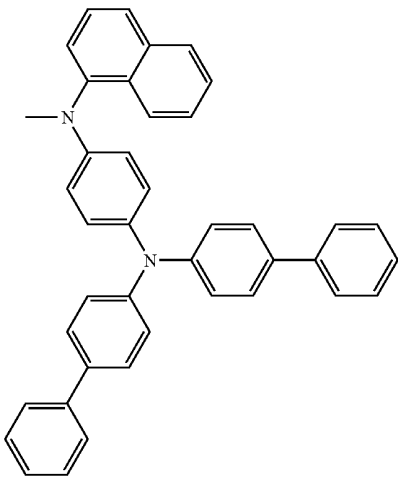
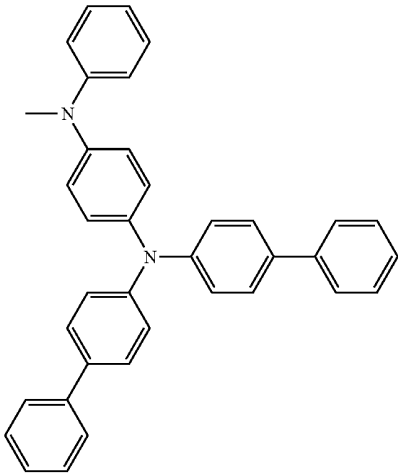
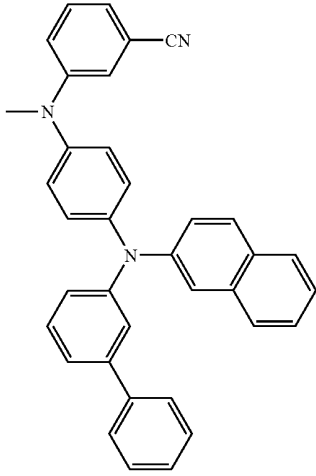

**288**  
-continued

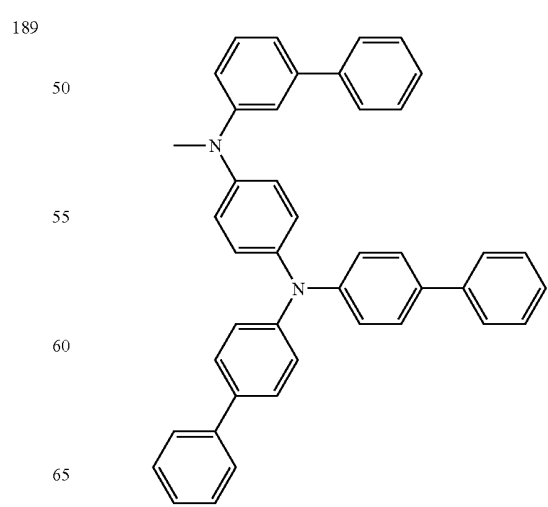
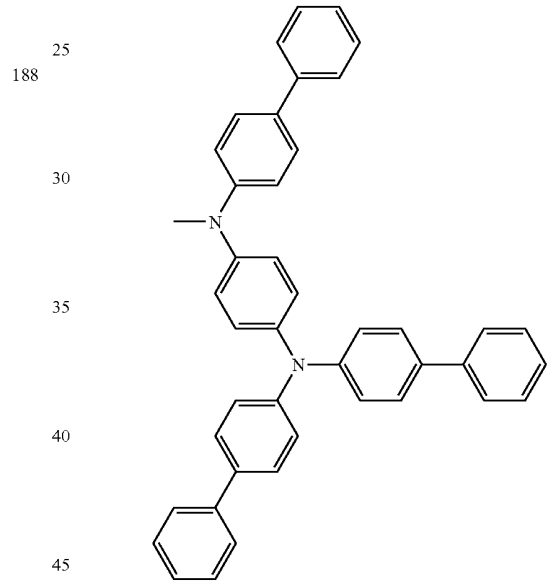
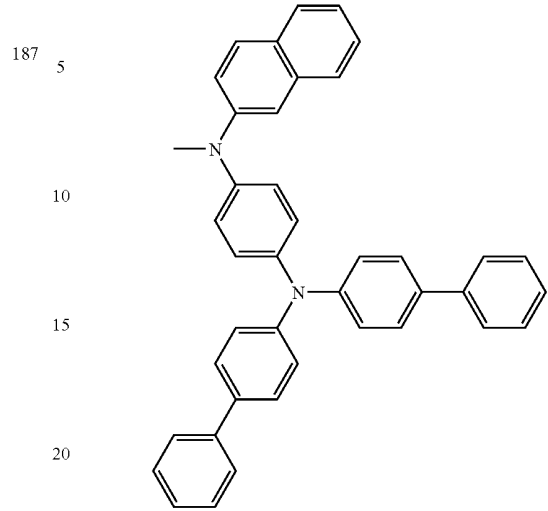

190

191

192

289

-continued

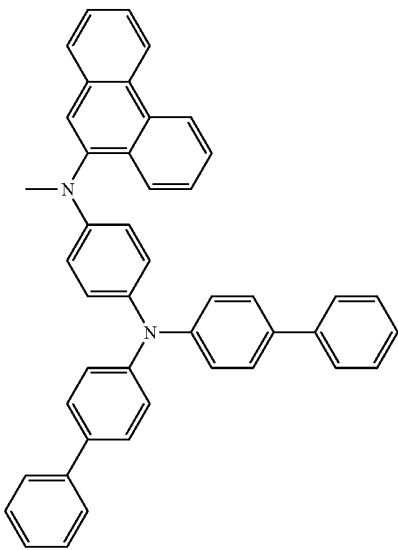
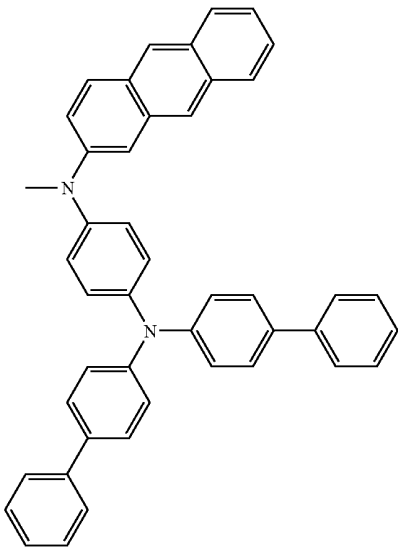
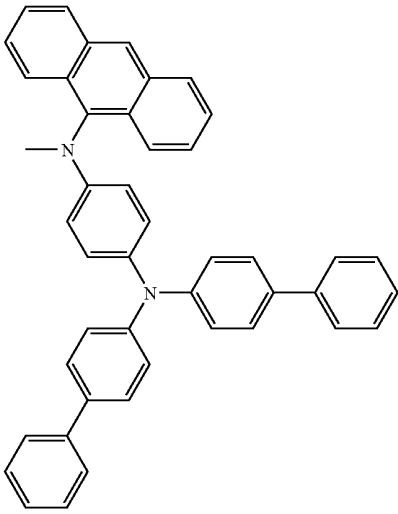

290

-continued

193

196

5

10

15

20

194

25

30

35

40

195

45

50

55

60

65

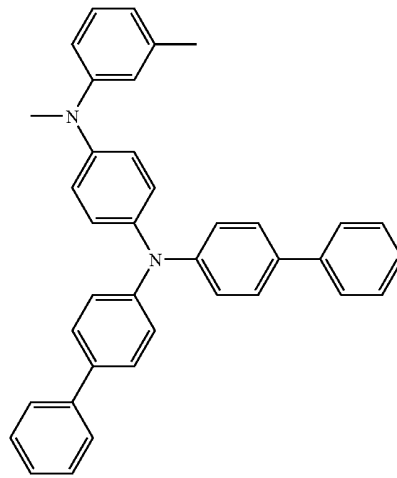
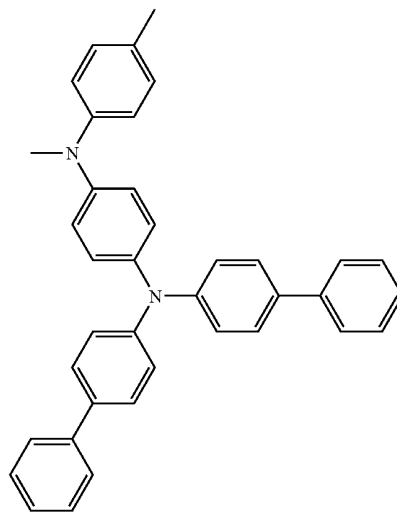
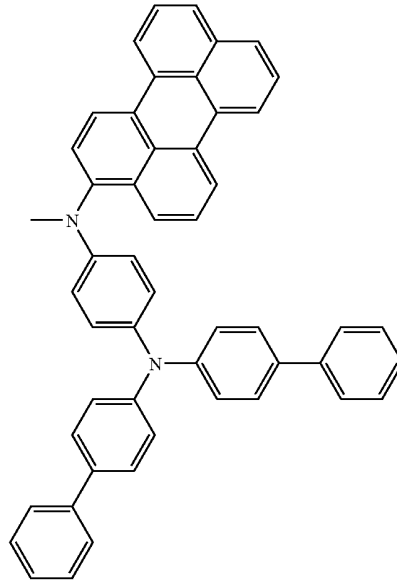

197

198

**291**

-continued

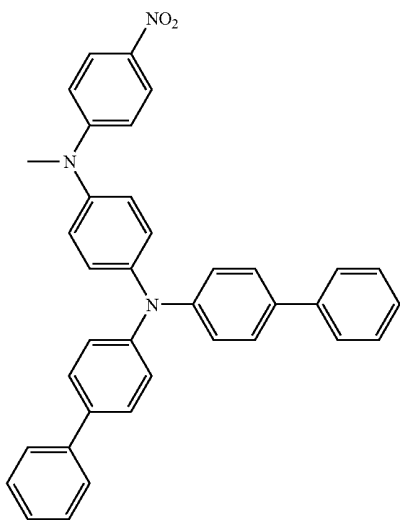
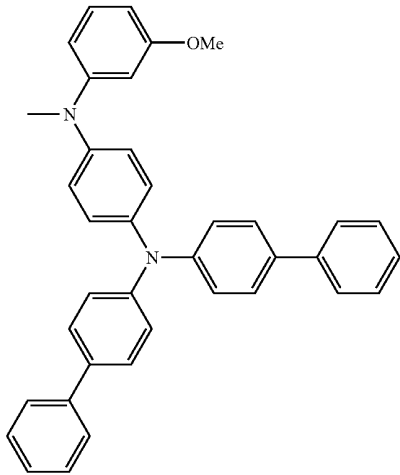
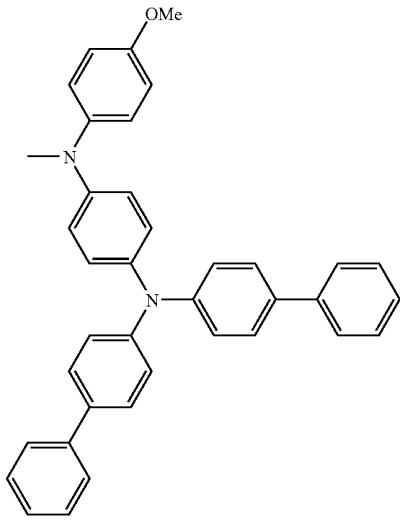

**292**

-continued

199

5

10

15

20

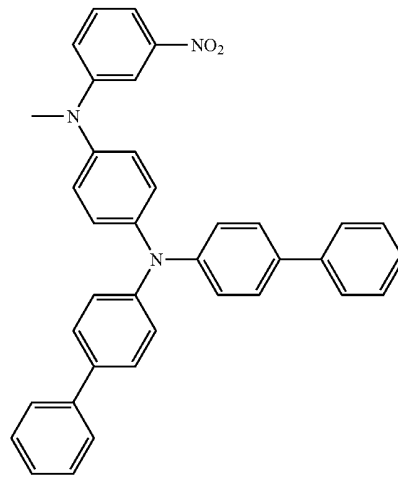

202

200

25

30

35

40

45

201

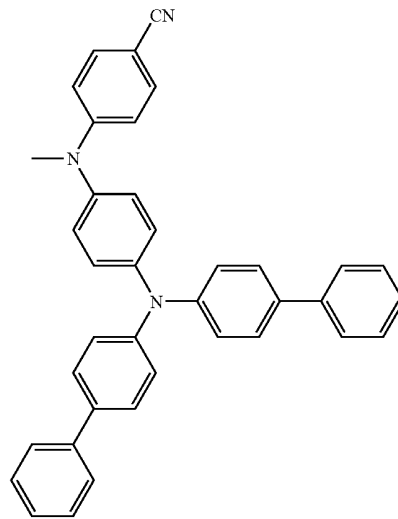

203

50

55

60

65

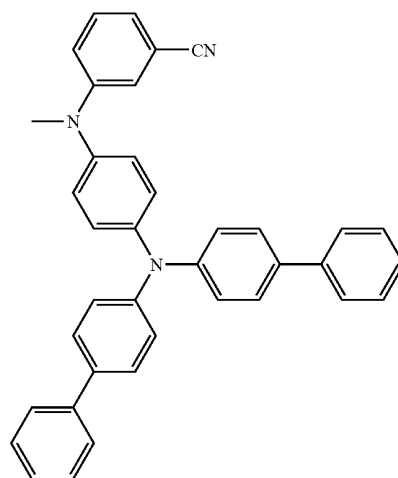

204

293

-continued

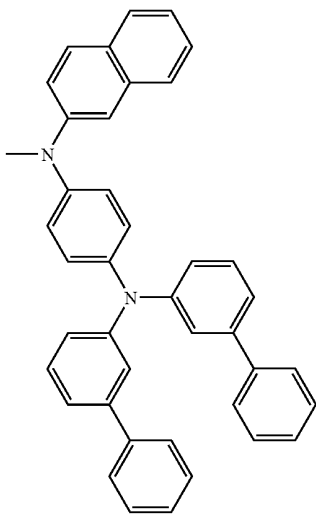
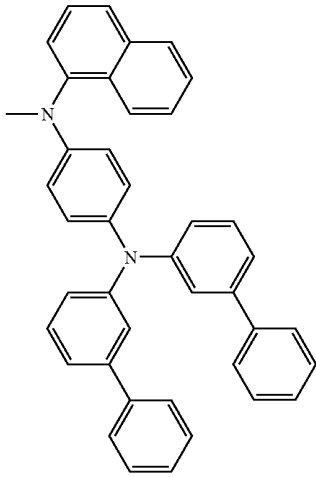
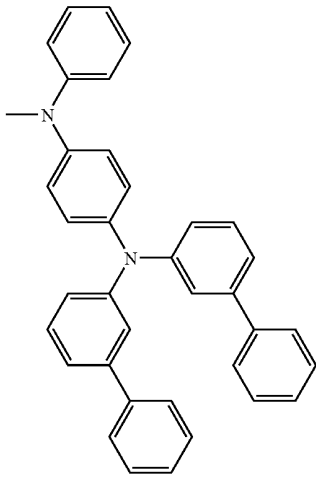

294

-continued

205

208

5

10

15

20

206

25

209

30

35

40

45

207

50

55

60

65

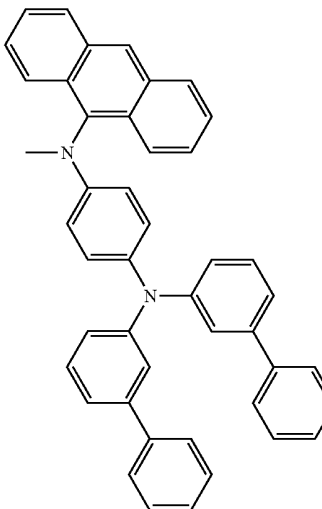
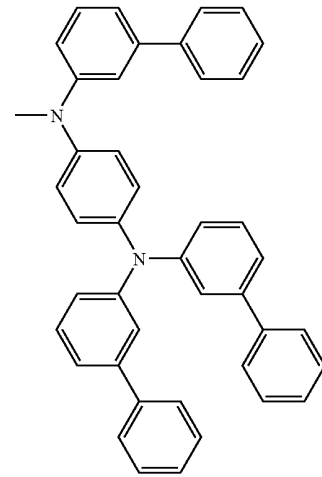
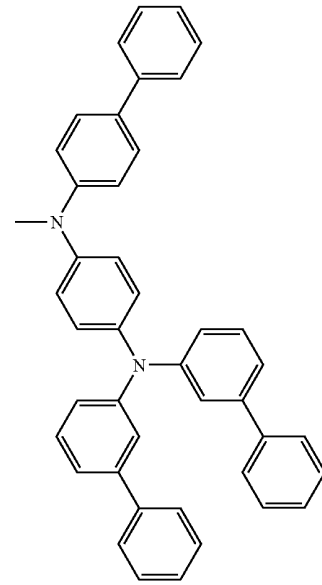

295

-continued

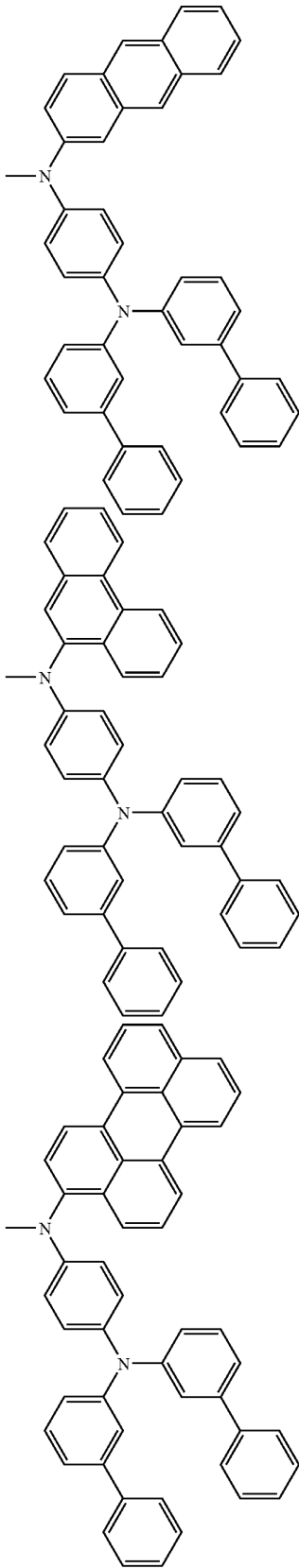

296

-continued

211

5

10

15

20

212

25

30

35

40

213

45

50

55

60

65

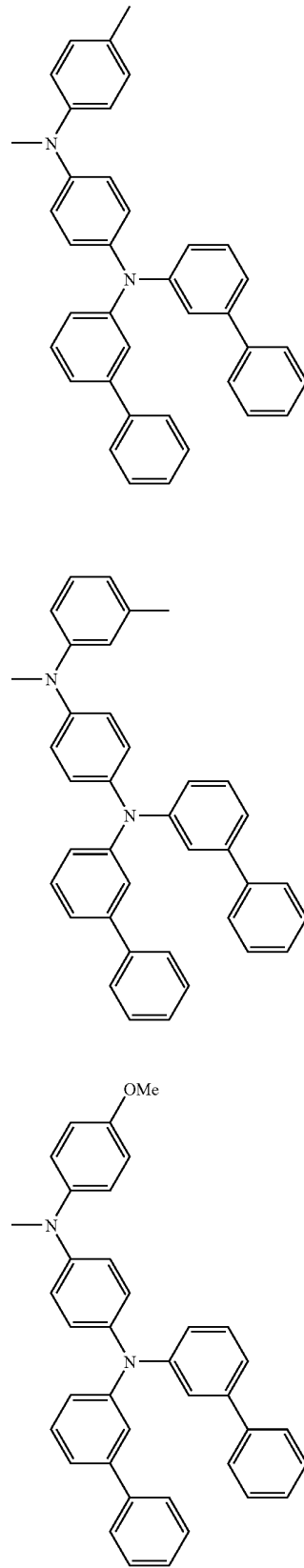

214

215

216

27

-continued

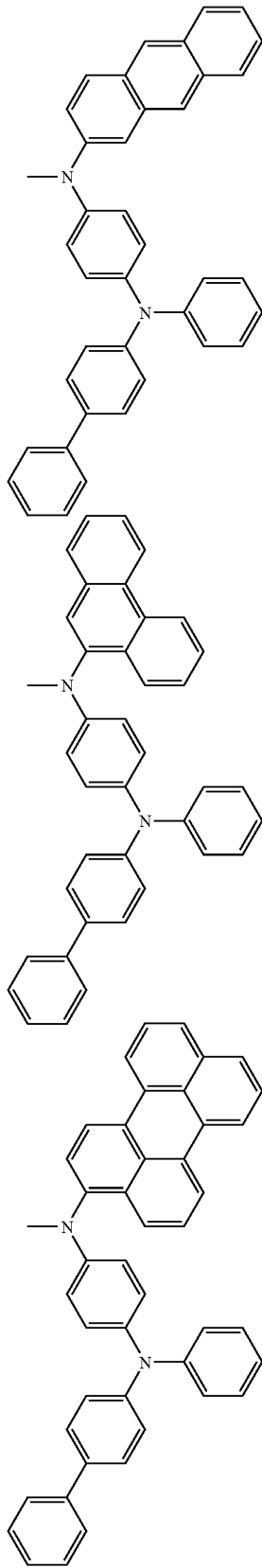

58

28

-continued

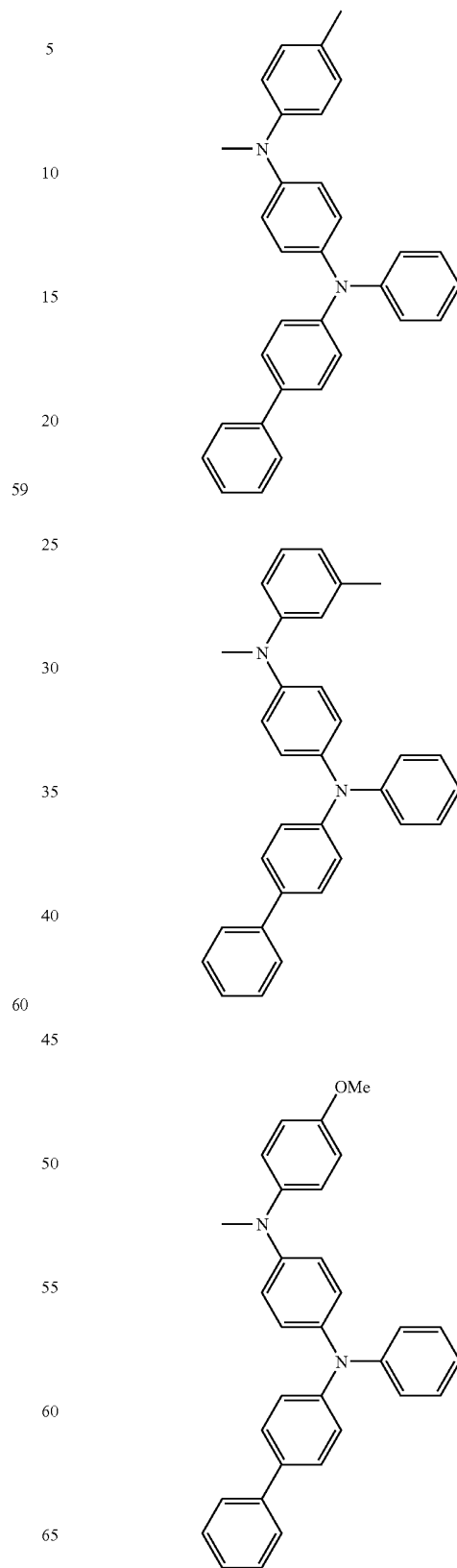

61

59

62

60

63

**297**  
-continued

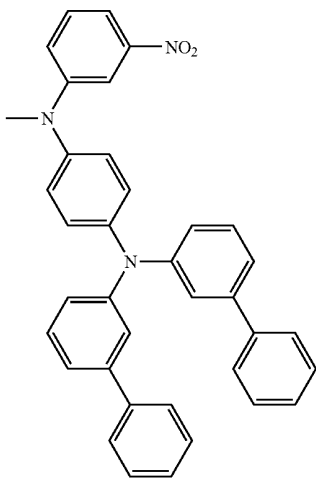
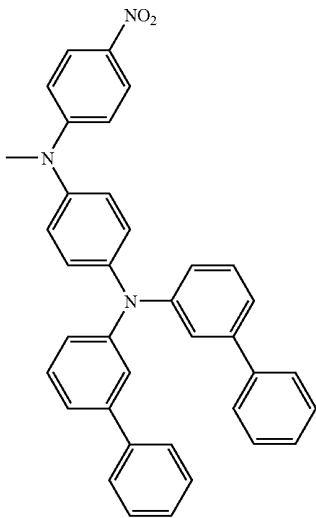
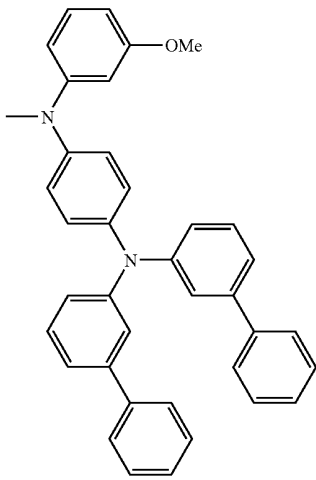

**298**  
-continued

217

5

10

15

20

218

25

30

35

40

45

219

50

55

60

65

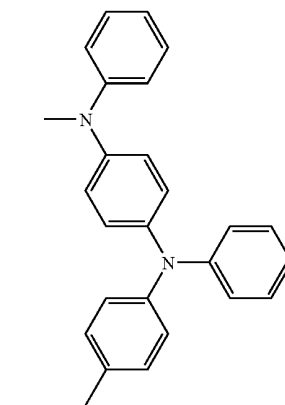
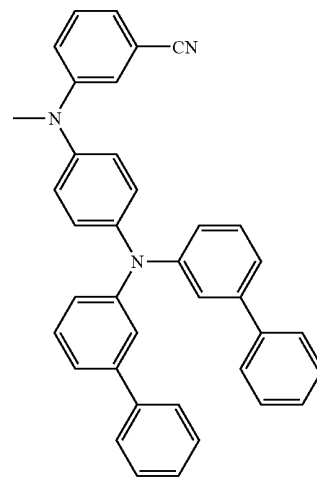
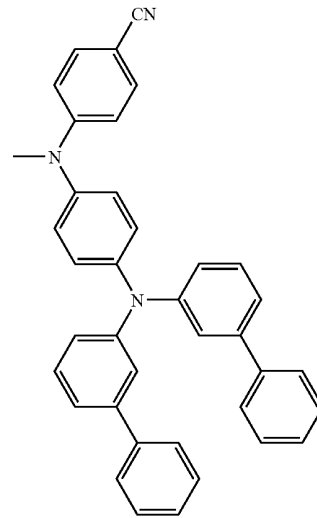

220

221

222

**299**  
-continued

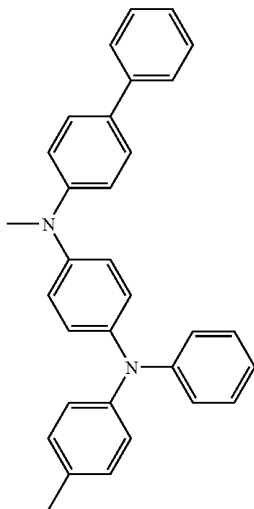
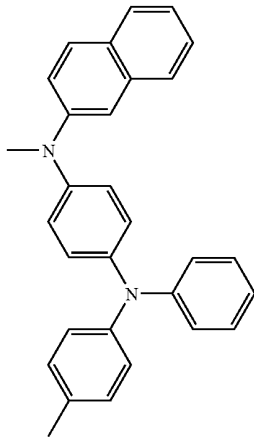
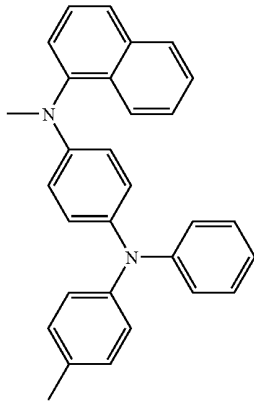

**300**  
-continued

223 5  
10  
15  
20

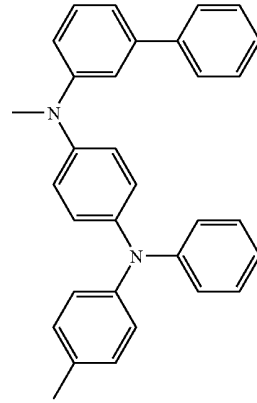

226

224 25  
30  
35  
40

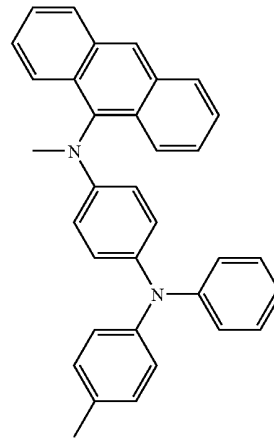

227

225 45  
50  
55  
60  
65

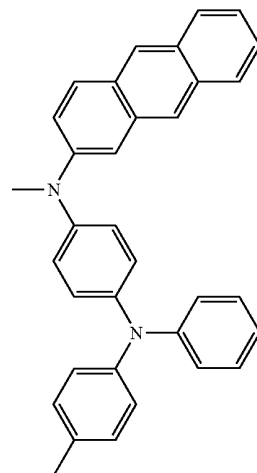

228

**301**  
-continued

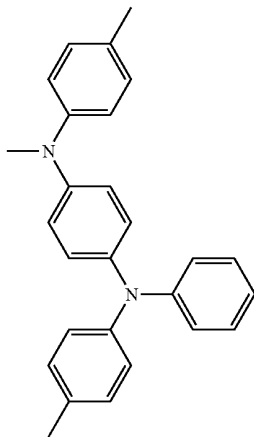
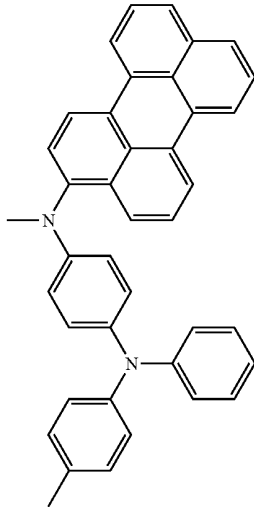
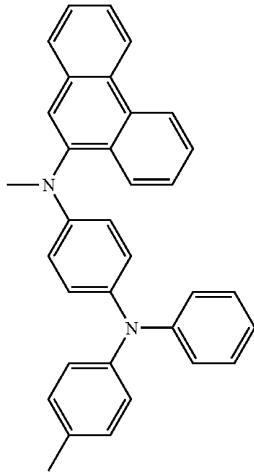

**302**  
-continued

229 5

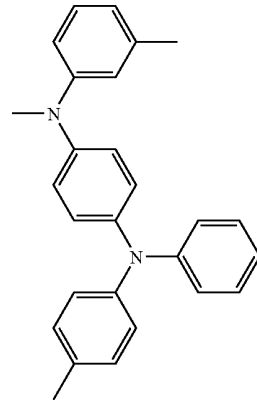

232

10

15

20

25

230

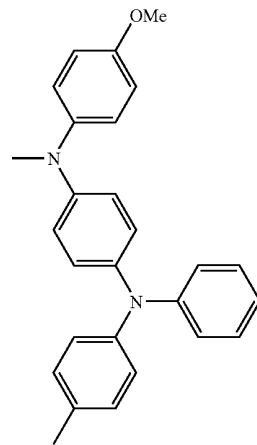

233

30

35

40

45

231

50

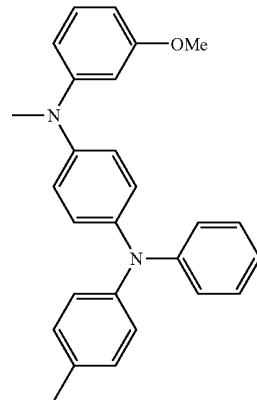

234

55

60

65

303

-continued

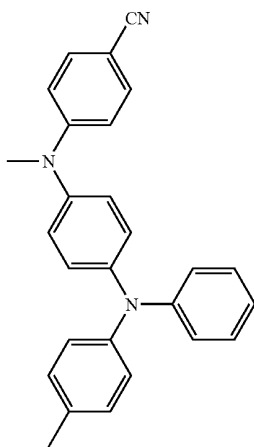
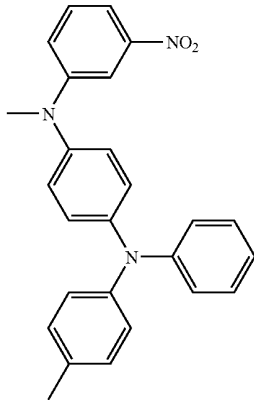
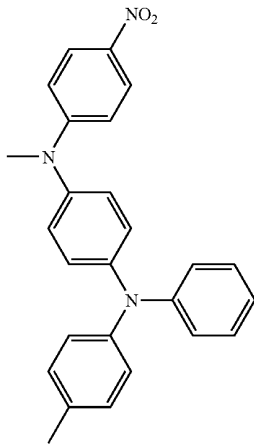

304

-continued

235 5

10

15

20

25

236

30

35

40

45

237

50

55

60

65

238

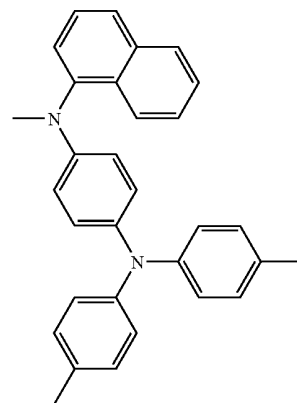
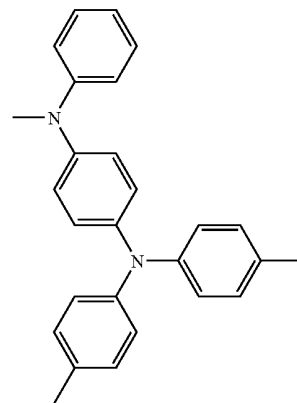
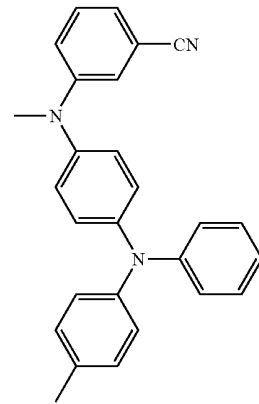

239

240

**305**  
-continued

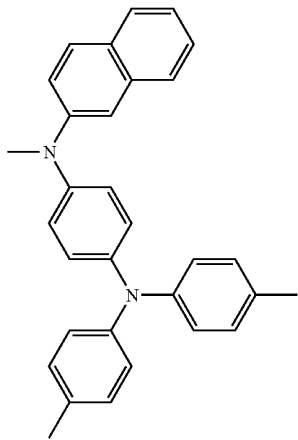

241 5

**306**  
-continued

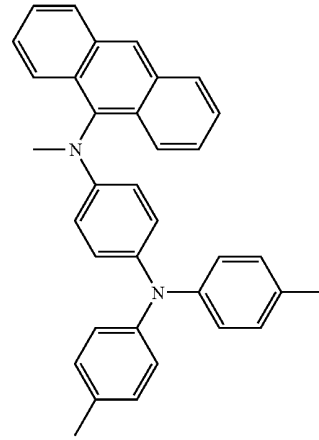

244

10

15

20

242 25

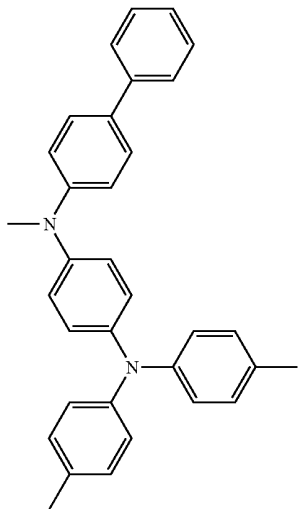

245

30

35

40

45

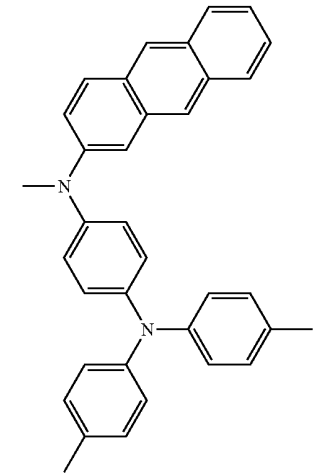

243 50

246

55

60

65

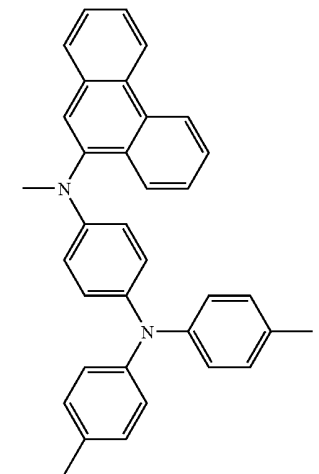
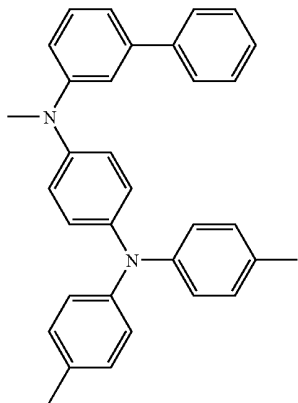

**307**  
-continued

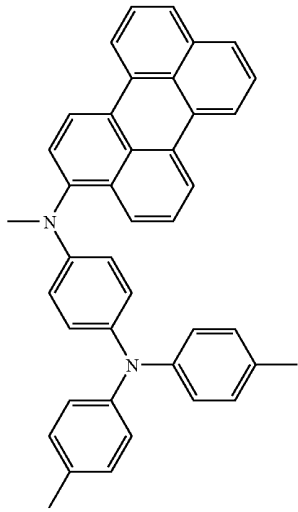

247 5

10

15

20

25

**308**  
-continued

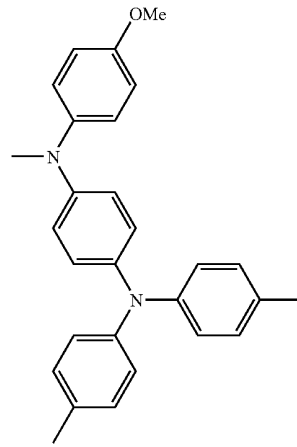

250

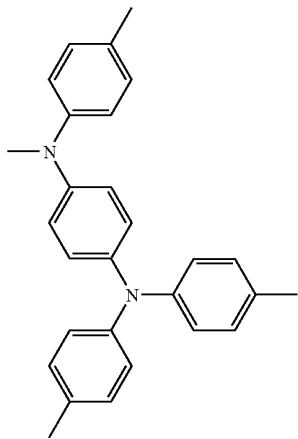

248

30

35

40

45

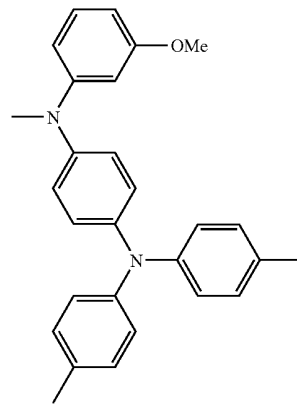

251

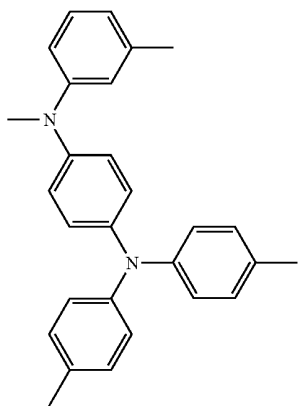

249

50

55

60

65

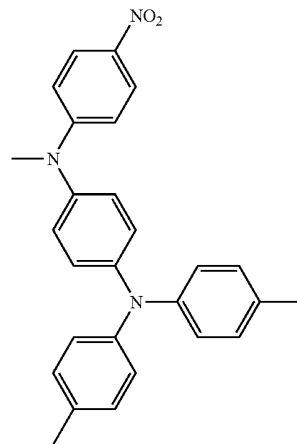

252

**309**  
-continued

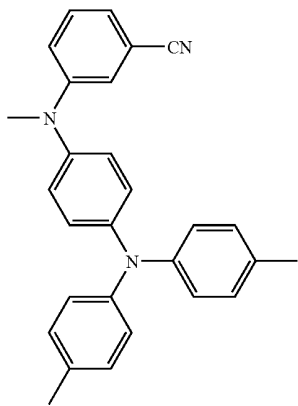
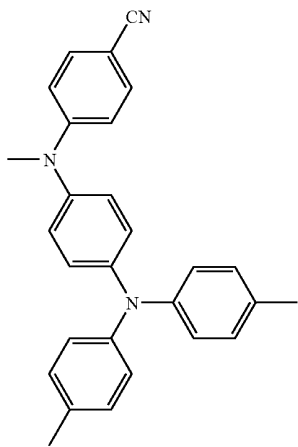
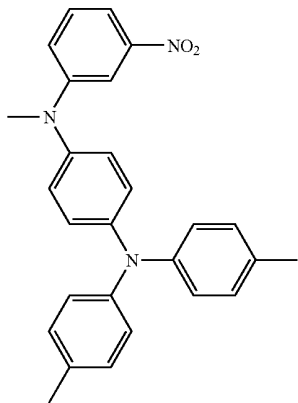

**310**  
-continued

253  
5

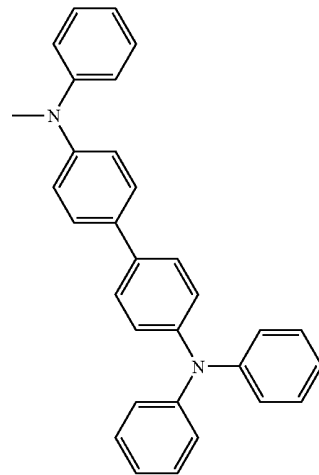

256

25

254

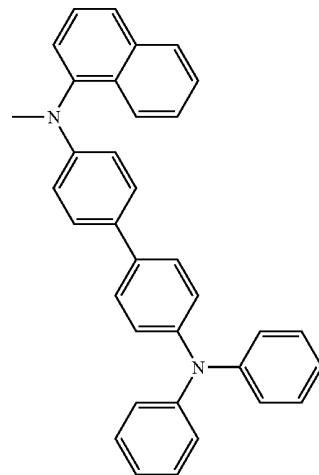

257

45

255

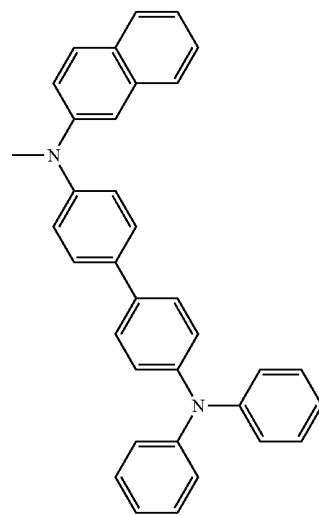

258

55

60

65

311

-continued

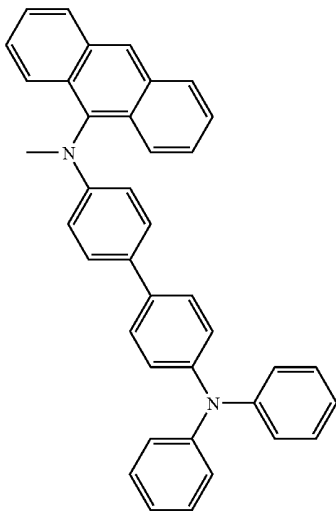
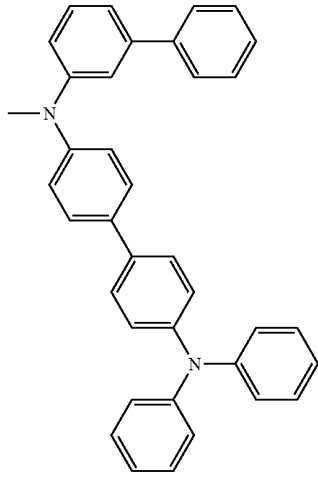
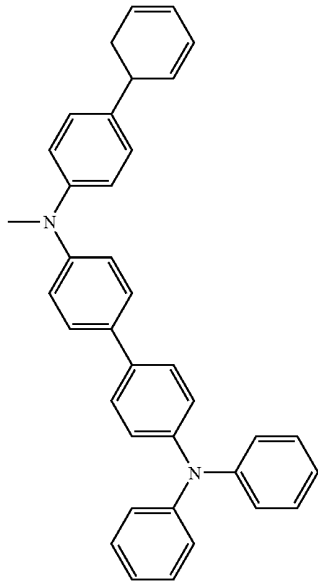

312

-continued

259

5

10

15

20

25  
260

30

35

40

45  
261

50

55

60

65

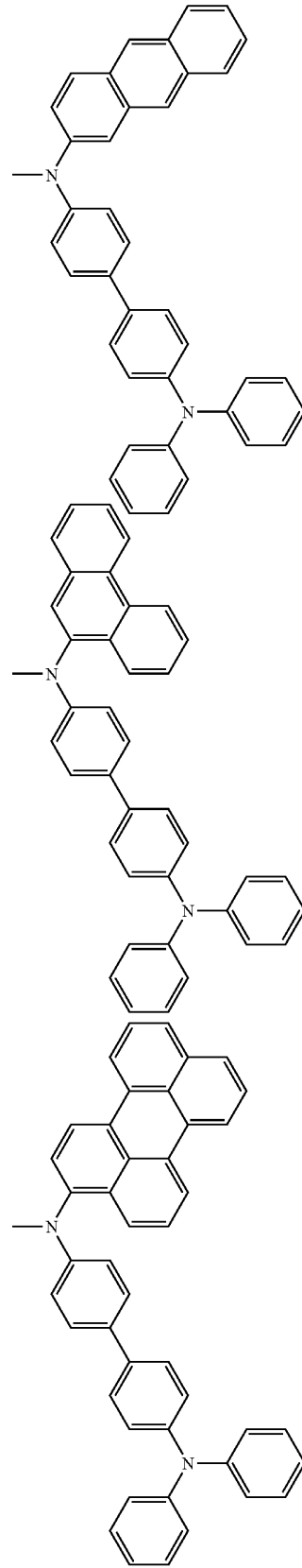

262

263

264

**313**  
-continued

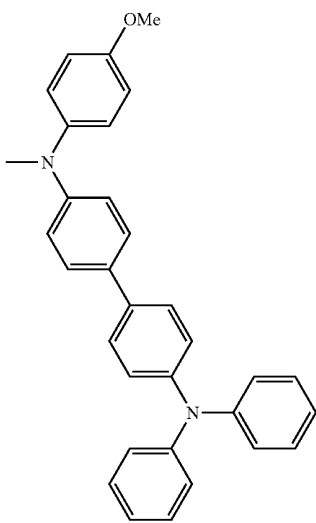
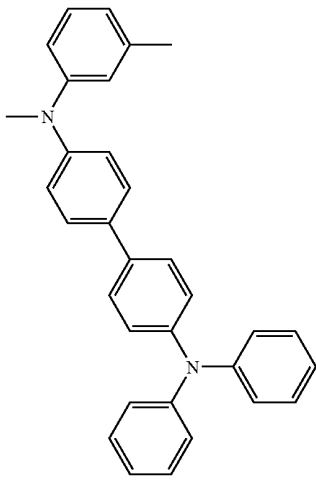
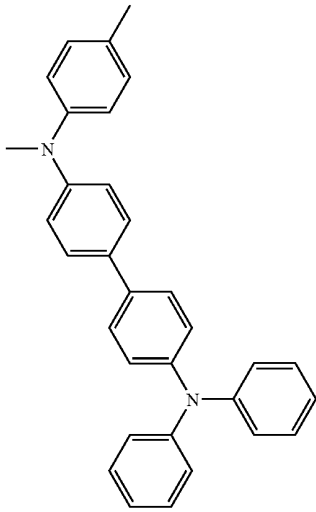

**314**  
-continued

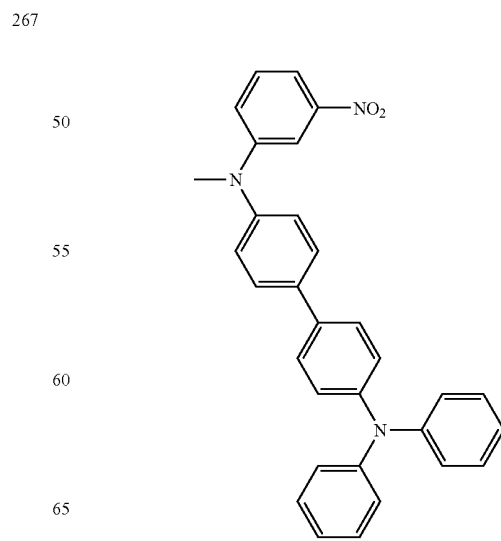
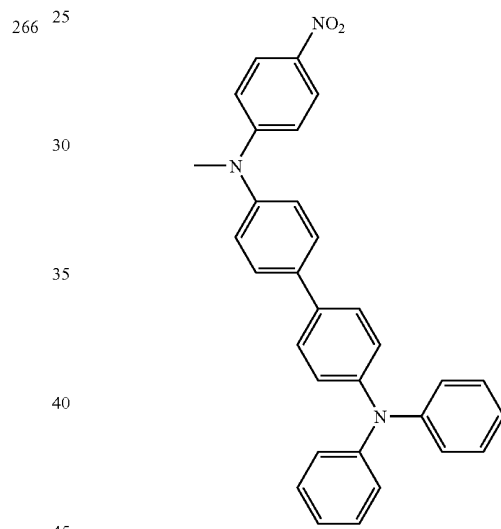
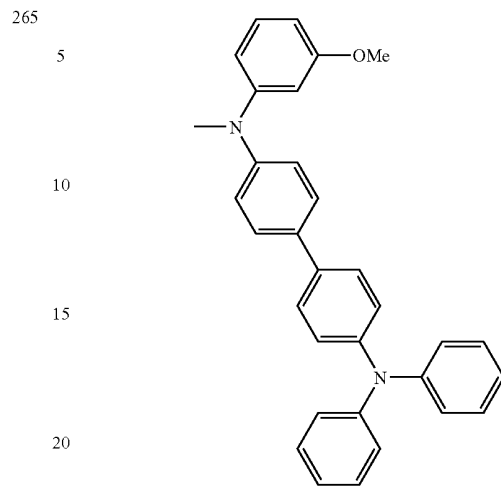

268

269

270

315

-continued

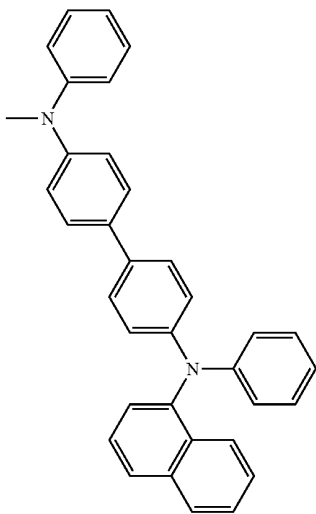
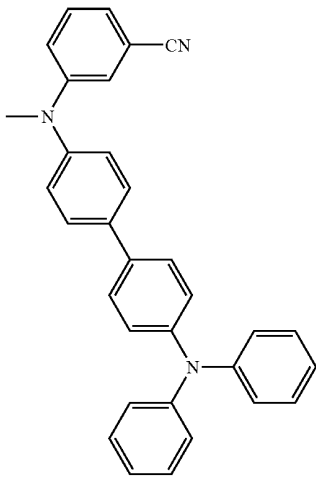
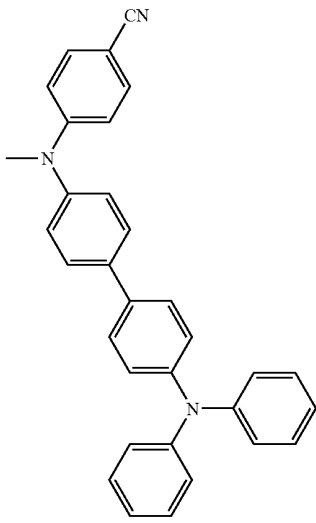

316

-continued

271

274

5

10

15

20

272 25

30

35

40

45

273

50

55

60

65

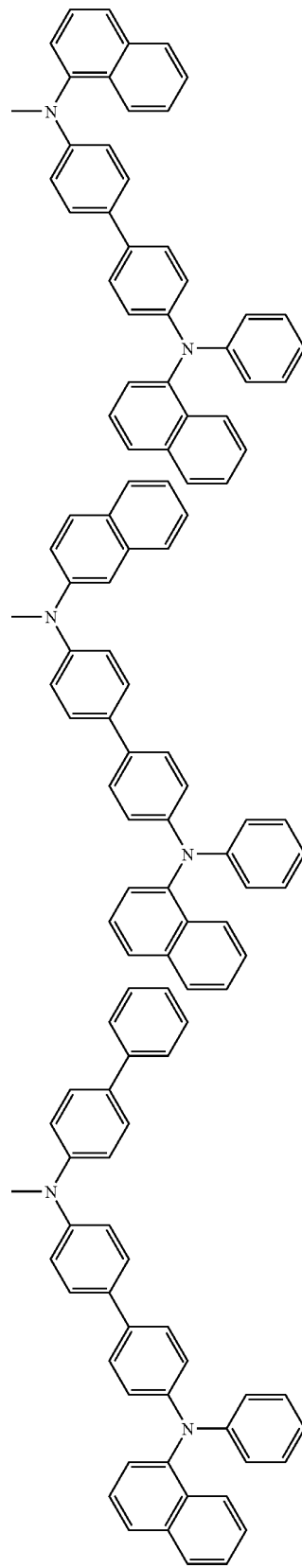

275

276

29

-continued

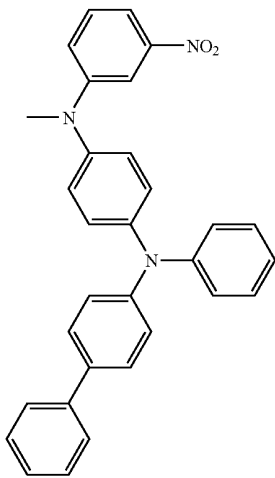
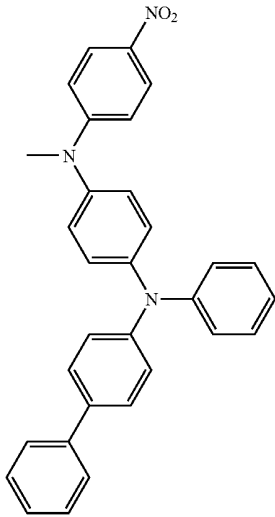
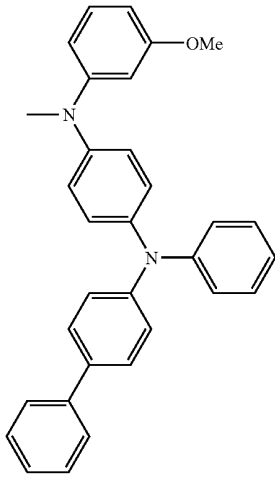

30

-continued

64

5

10

15

20

25

30

35

40

45

66

50

55

60

65

67

68

69

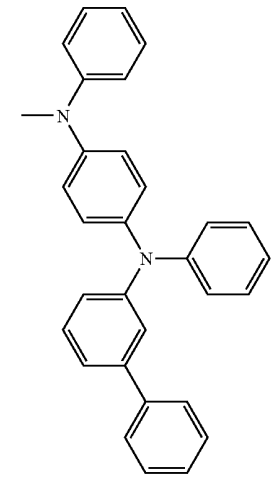
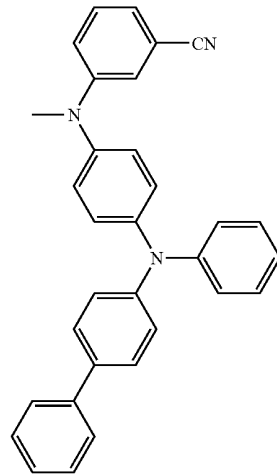
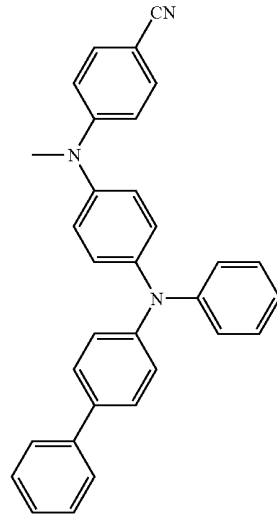

317

-continued

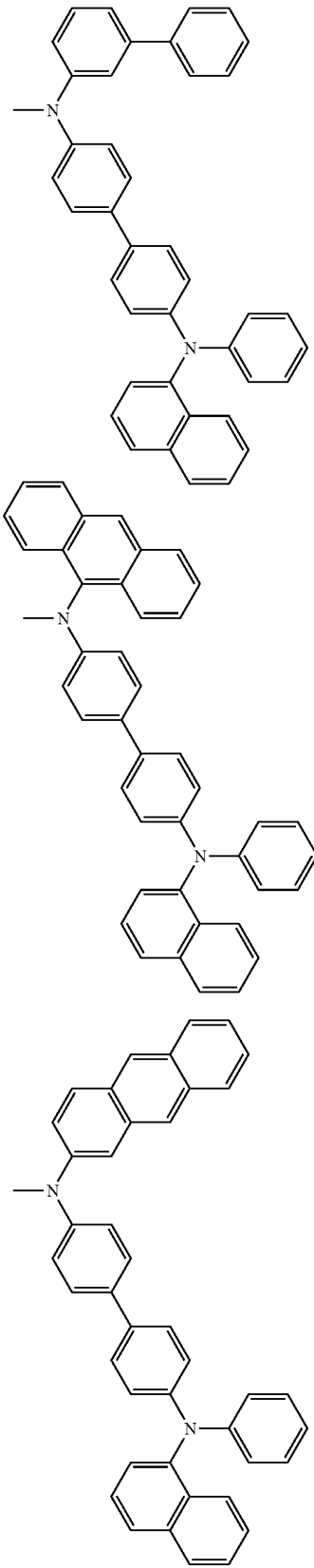

277

5

10

15

20

278

25

30

35

40

279

45

50

55

60

65

318

-continued



280

281

319

-continued

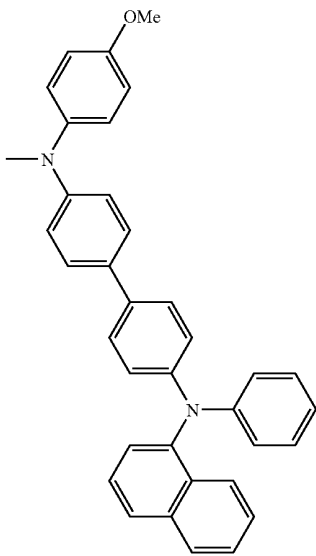
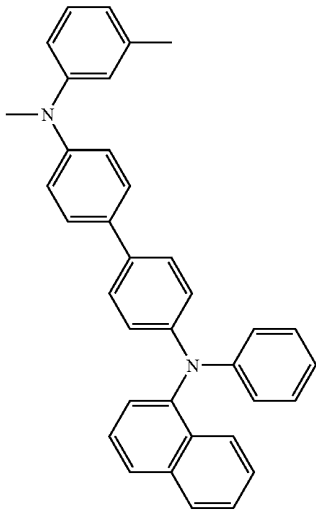
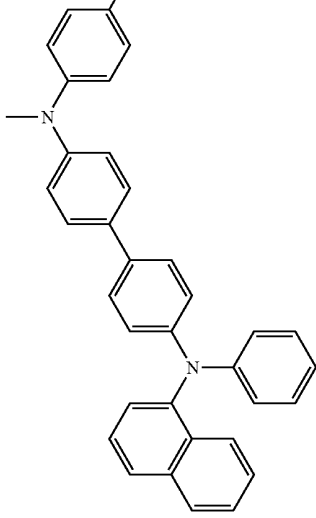

320

-continued

282

285

5

10

15

20

283

286

25

30

35

40

284

287

45

50

55

60

65

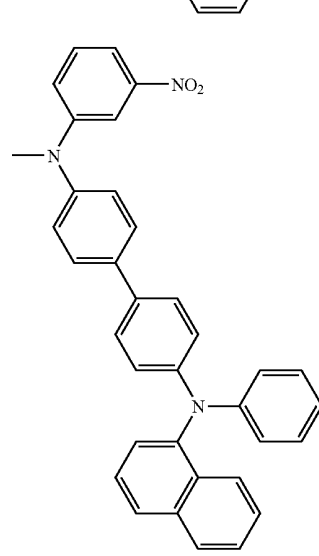
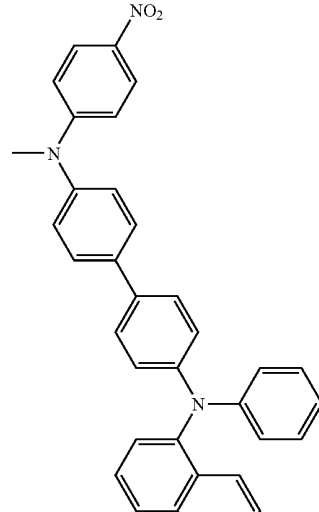
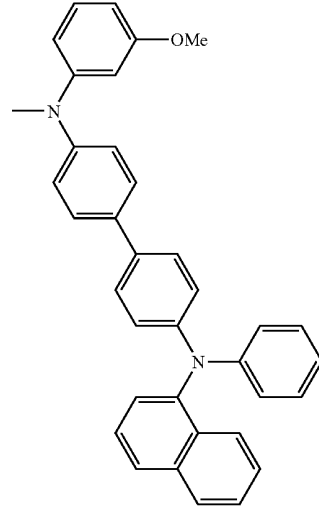

**321**

-continued

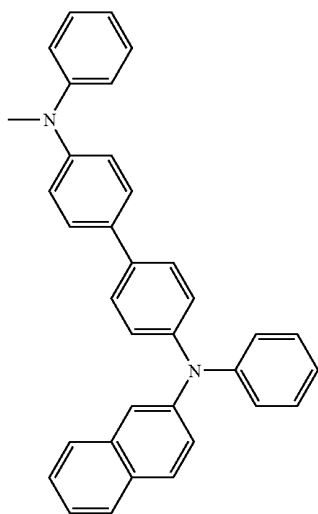
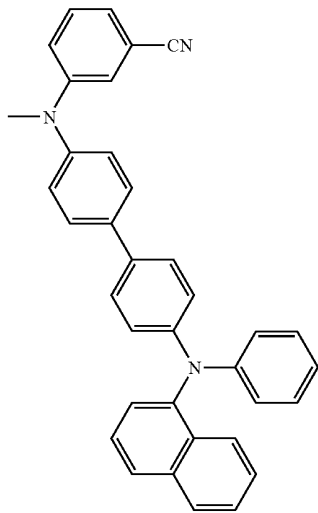
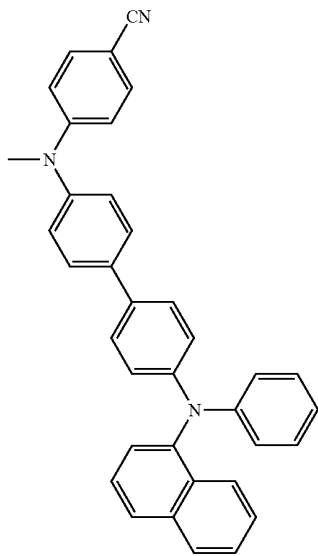

**322**

-continued

288

5

10

15

20

289

25

30

35

40

290

45

50

55

60

65

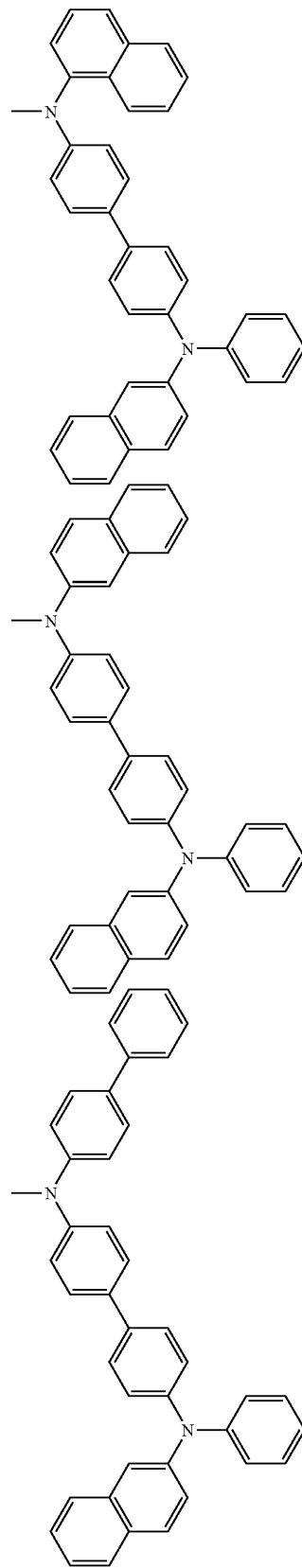

291

292

293

323

-continued

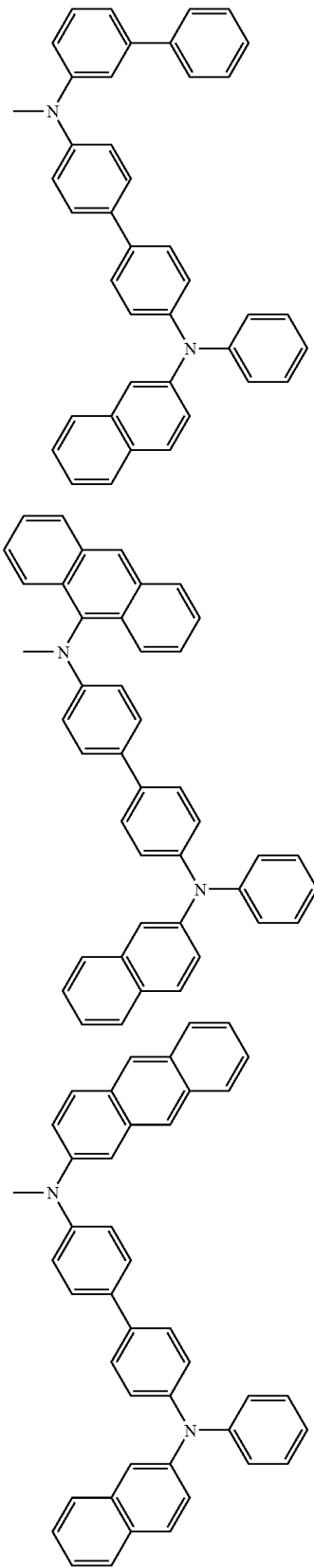

294

324

-continued

5  
10  
15  
20  
295  
25  
30  
35  
40  
296  
45  
50  
55  
60  
65



297

298

325

continued

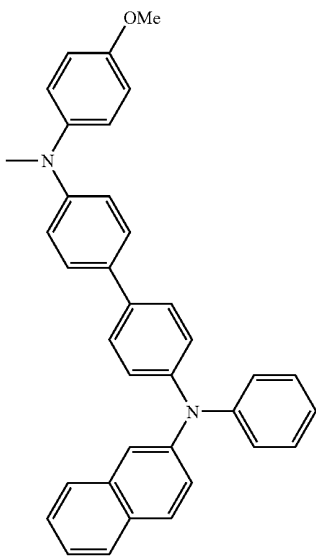
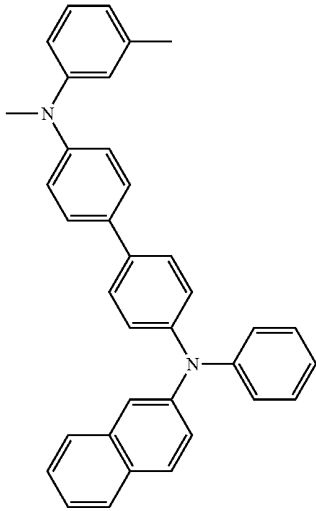
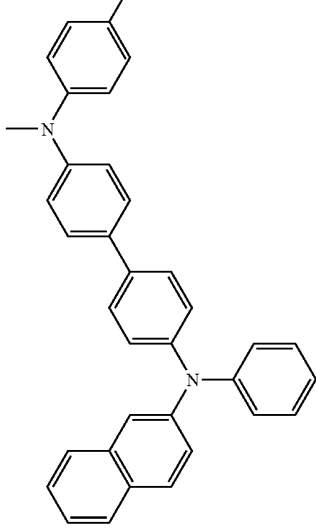

326

-continued

299

302

5

10

15

20

300

25

30

35

40

301 45

303

50

55

60

65

304

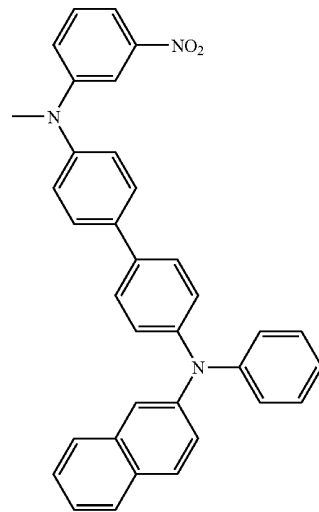
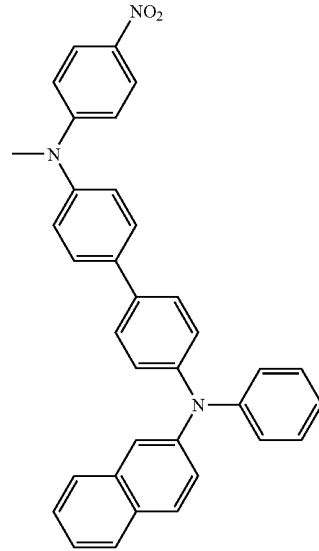
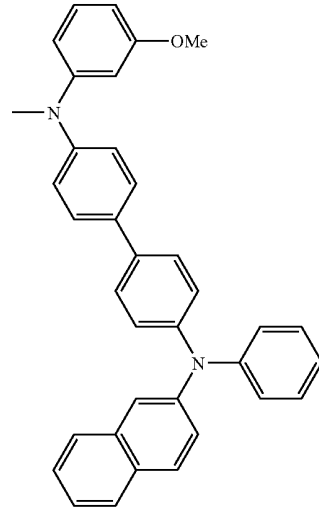

327

-continued

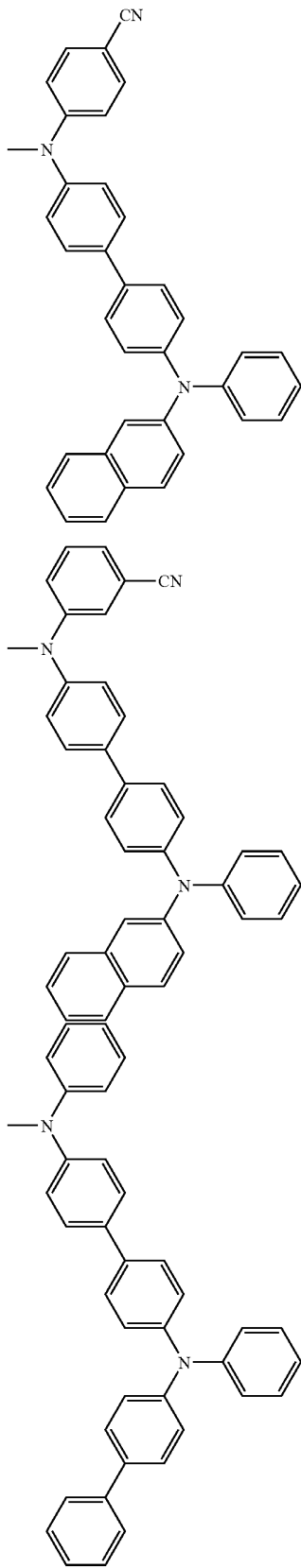

328

-continued

305

5

10

15

20

306

25

30

35

40

307

45

50

55

60

65

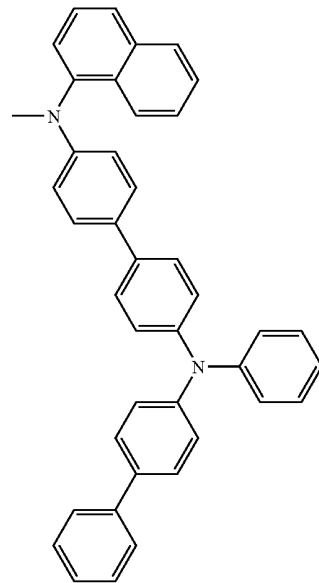

308

309

**329**  
-continued

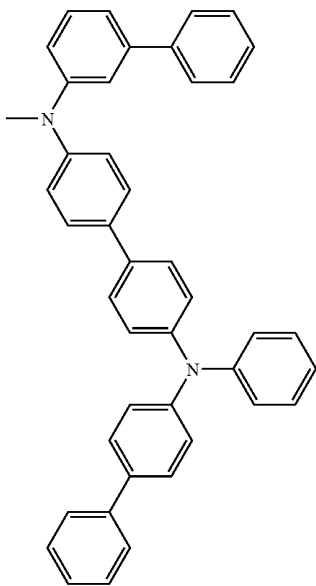
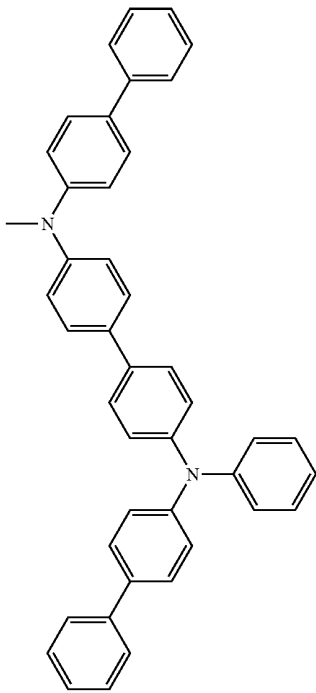

**330**  
-continued

310  
5

312

10

15

20

25

30

35

40

311

45

50

55

60

65

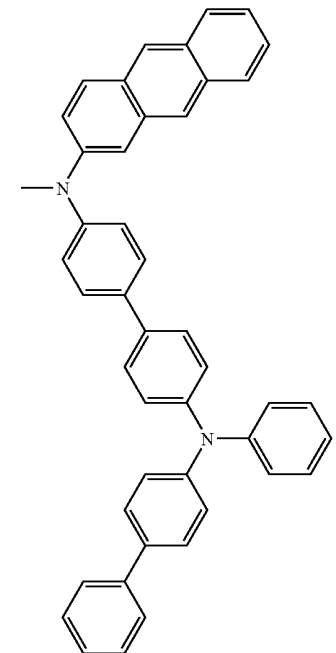
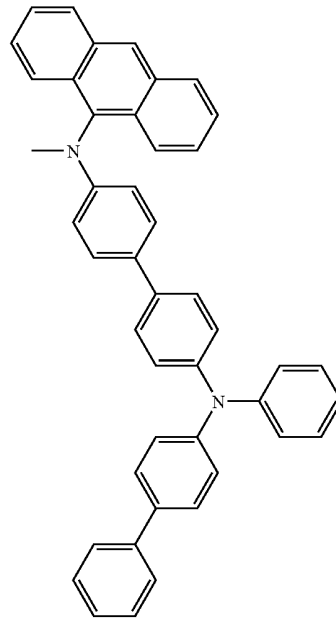

**331**  
-continued

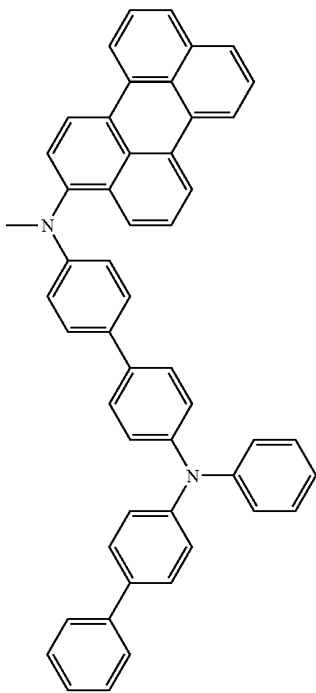
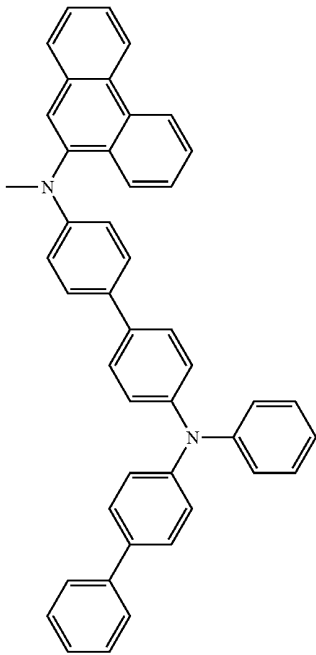

**332**  
-continued

5  
314  
10  
15  
20  
25  
30  
35

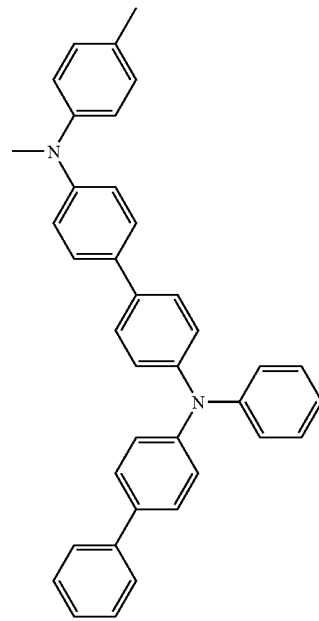

316

315  
40  
45  
50  
55  
60  
65

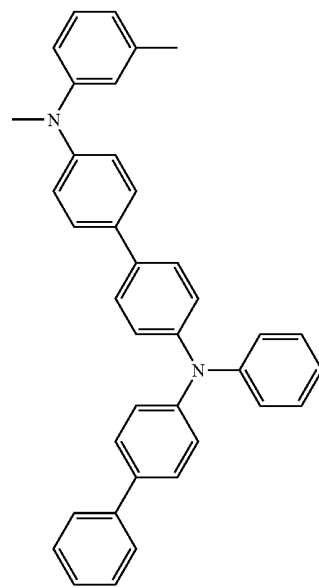

317

**333**  
-continued

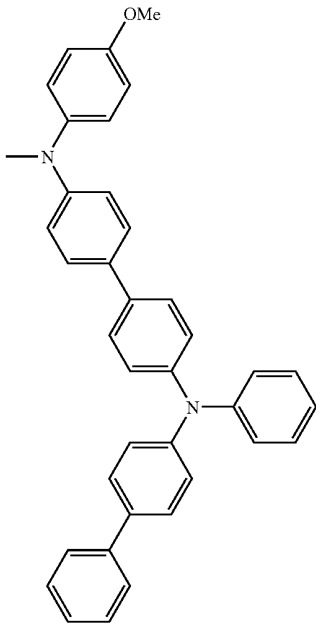

318 5

10

15

20

25

30

35

40

**334**  
-continued

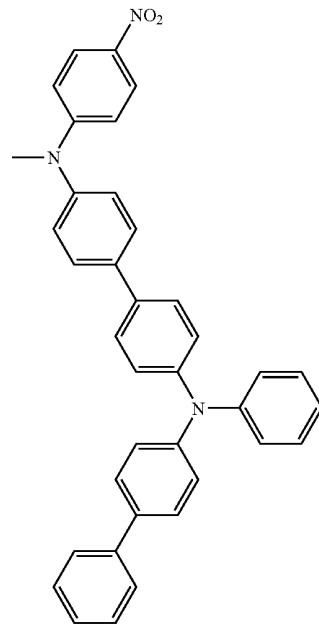

320

319

45

50

55

60

65

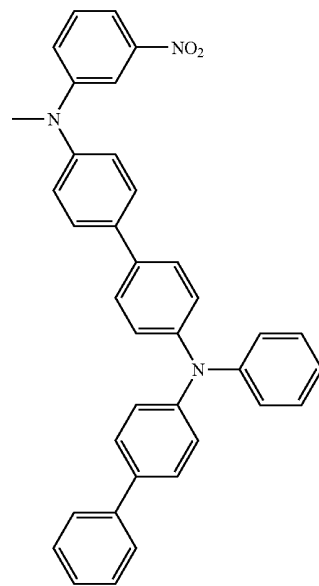
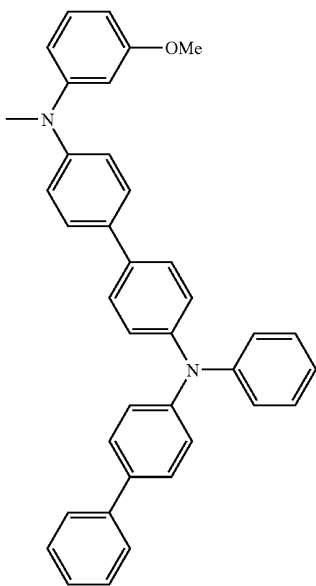

321

**335**  
-continued

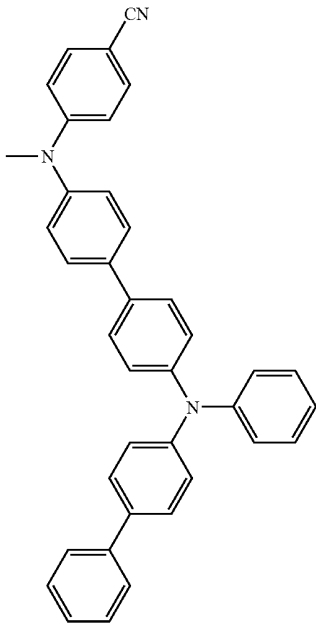

**336**  
-continued

322 5

324

10

15

20

25

30

35

40

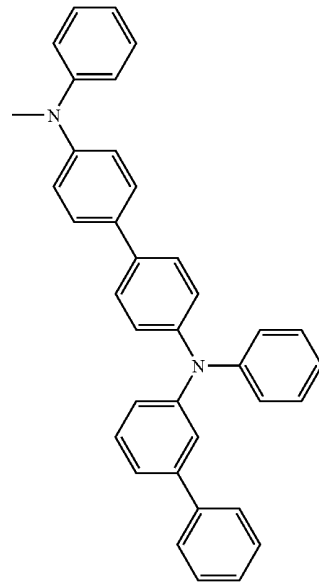

323

325

45

50

55

60

65

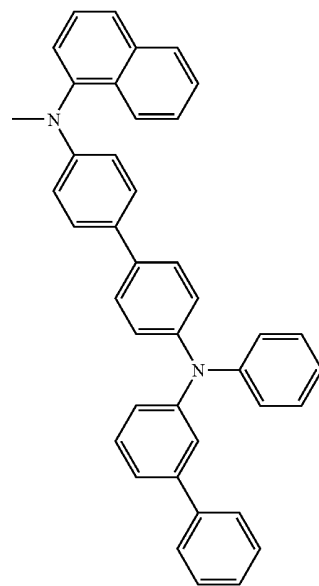
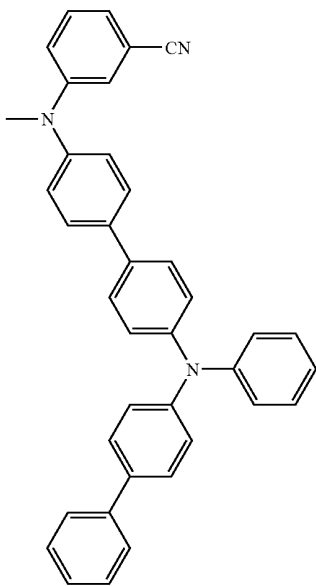

**31**

-continued

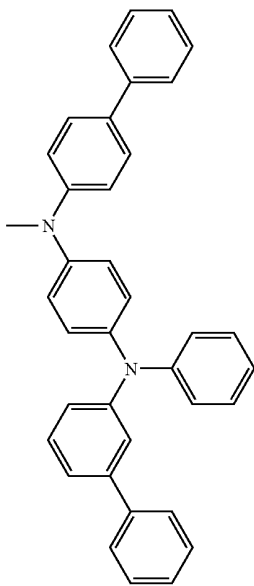
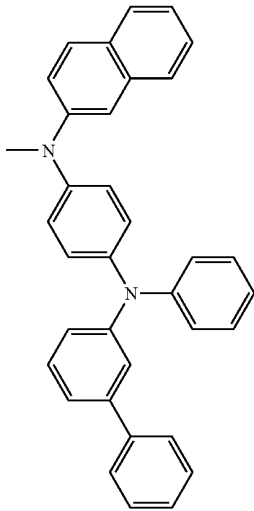
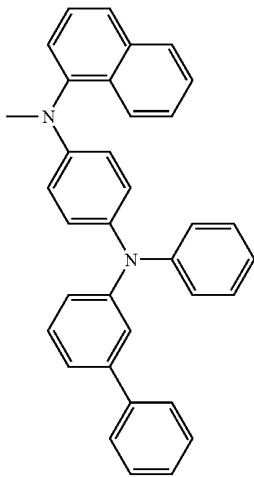

**32**

-continued

70

73

5

10

15

20

71

25

30

35

40

72

45

74

50

55

60

65

75

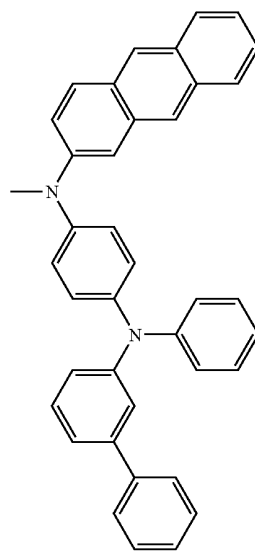
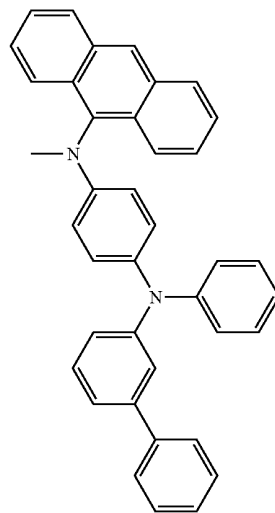
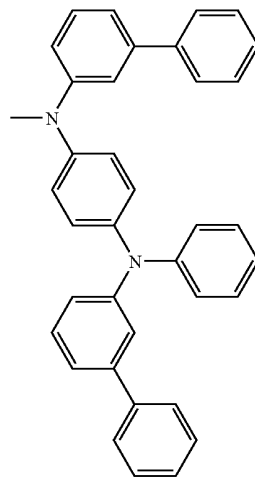

**337**  
-continued

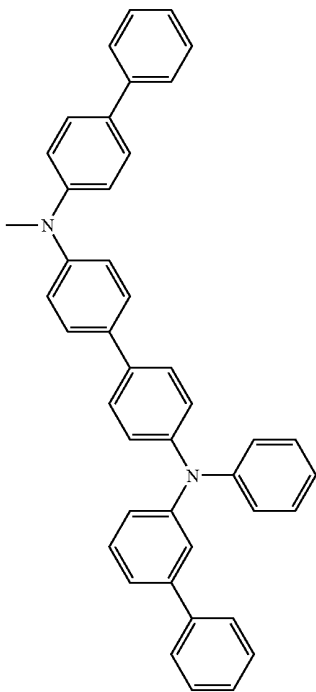
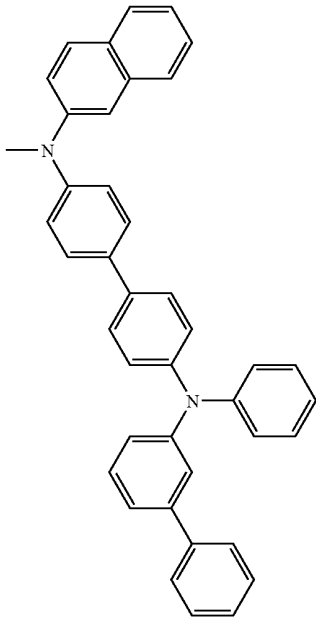

**338**  
-continued

326 5  
10  
15  
20  
25  
30  
35

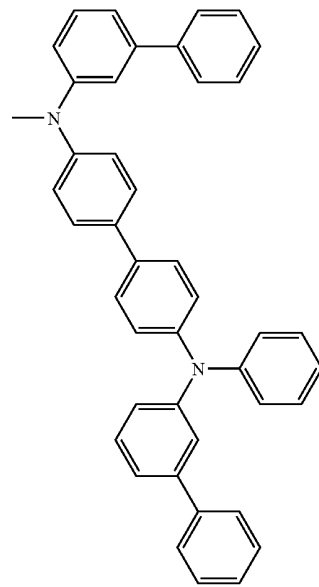

328

327 40  
45  
50  
55  
60  
65

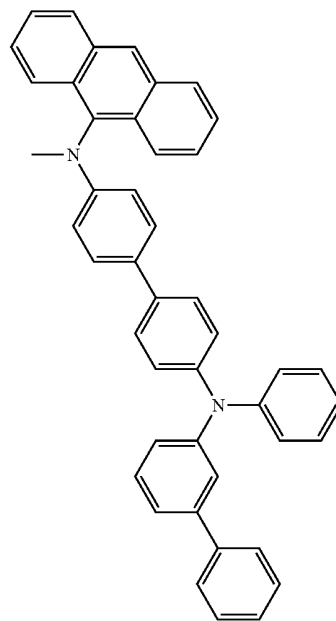

329

**339**  
-continued

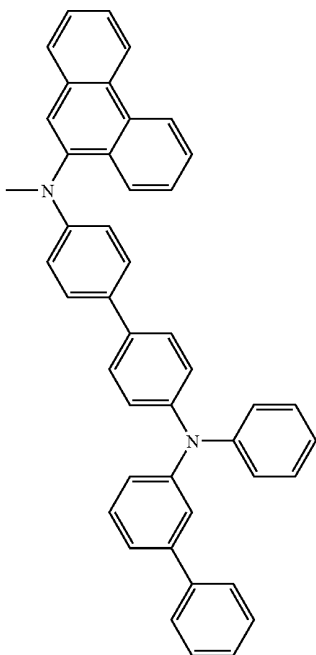
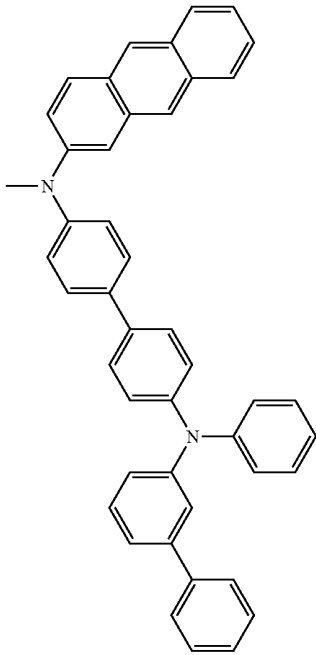

**340**  
-continued

330 5

332

10

15

20

25

30

35

40

331

333

45

50

55

60

65

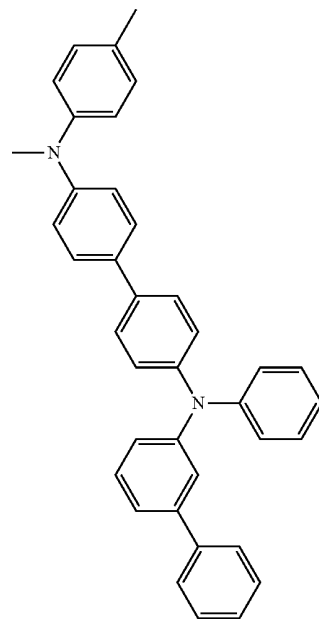
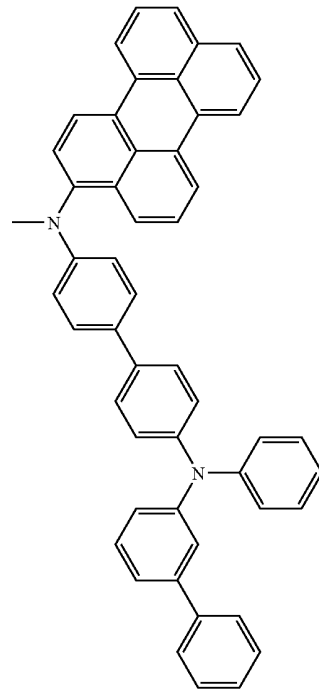

**341**  
-continued

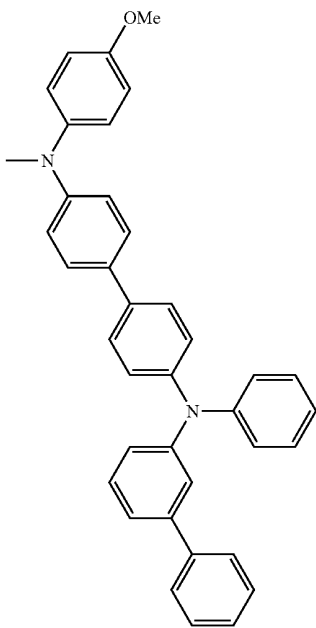
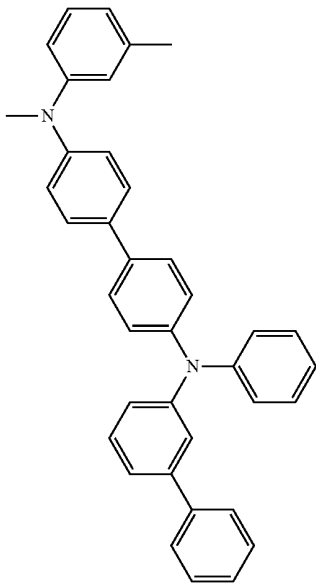

**342**  
-continued

5  
334  
10  
15  
20  
25  
30  
35

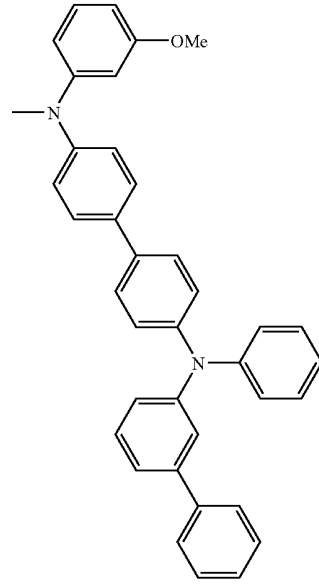

336

40  
335  
45  
50  
55  
60  
65

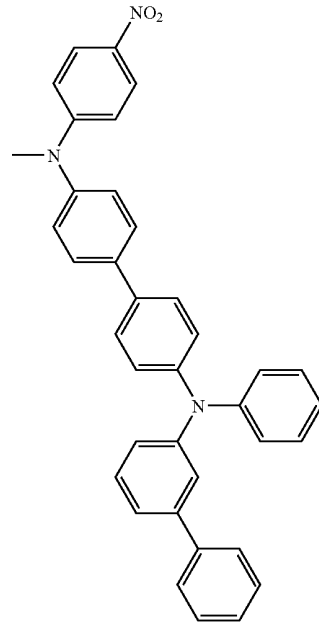

337

**343**  
-continued

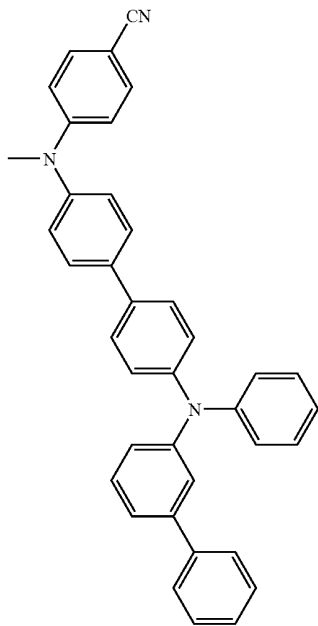
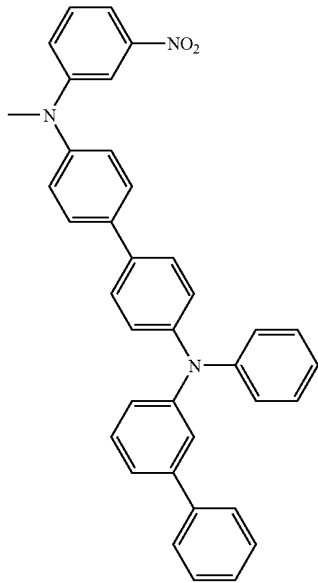

**344**  
-continued

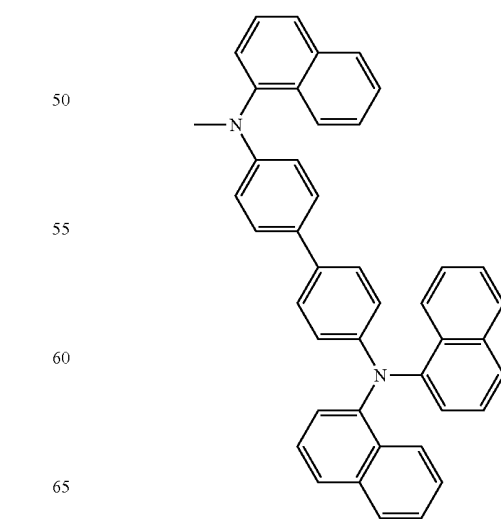
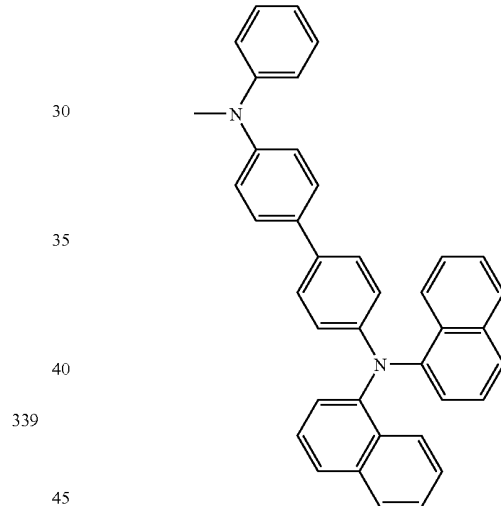
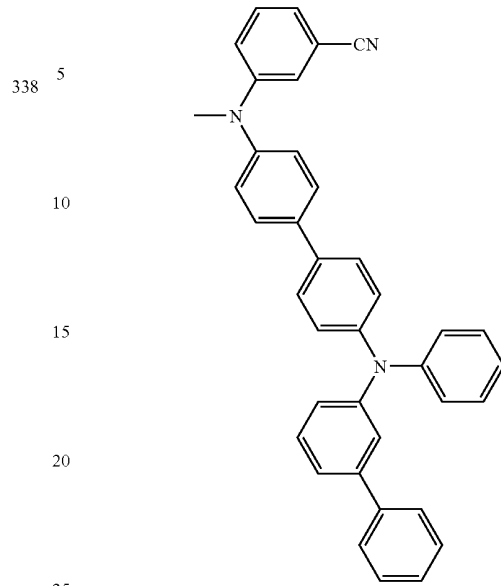

340

341

342

345

-continued

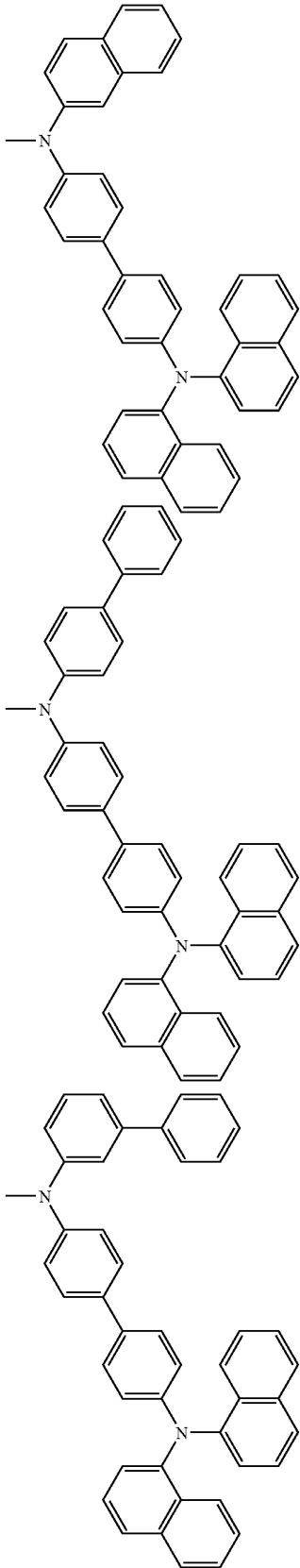

343

5

10

15

20

344

25

30

35

40

45

345

50

55

60

65

346

-continued

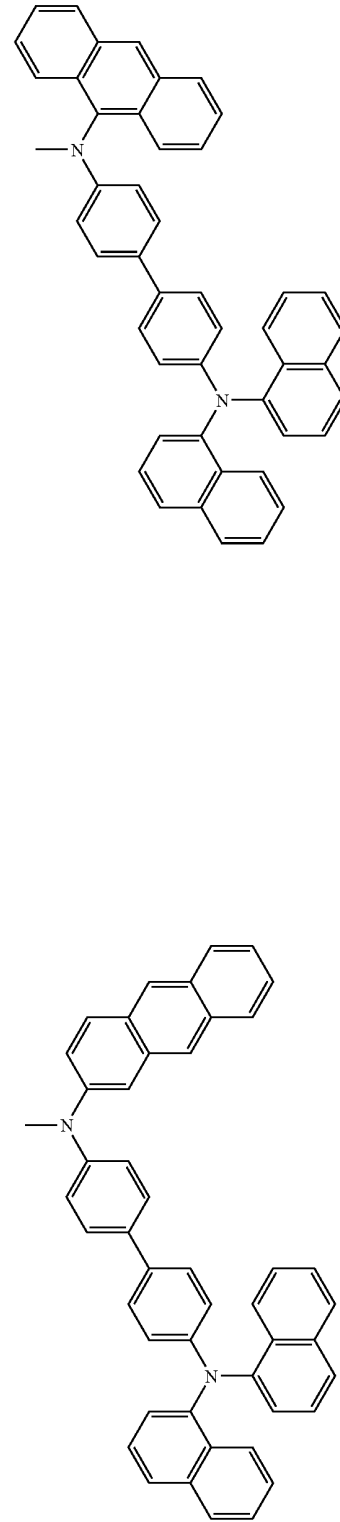

346

347

**347**  
-continued

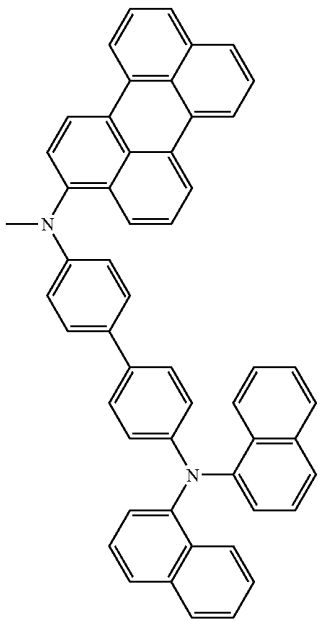
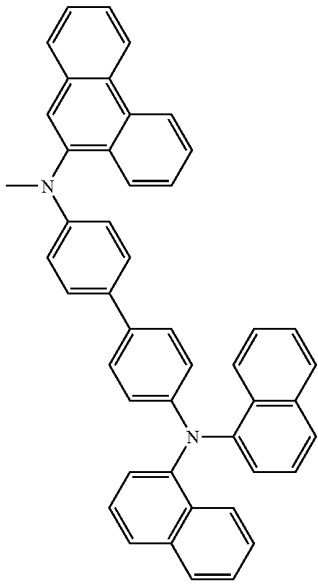

**348**  
-continued

348

5

10

15

20

25

30

35

40

349

45

50

55

60

65

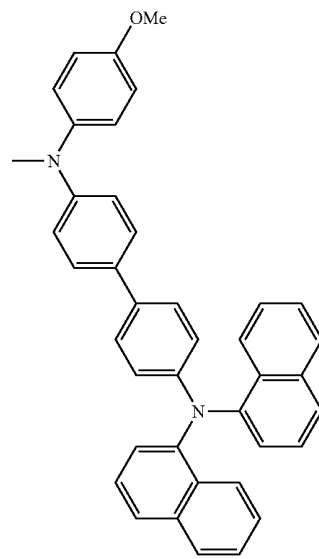
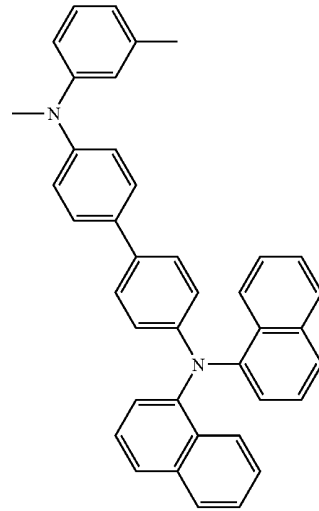
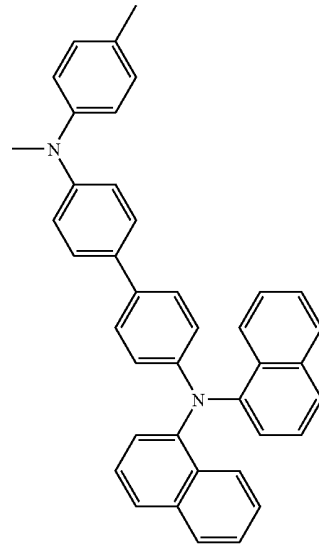

350

351

352

349

-continued

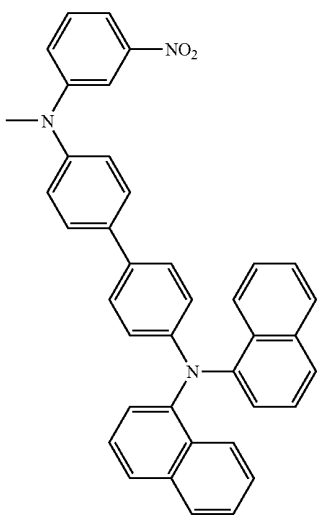
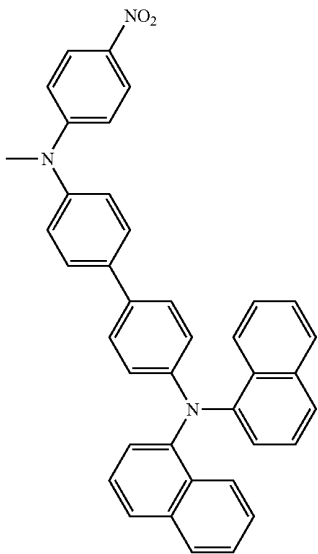
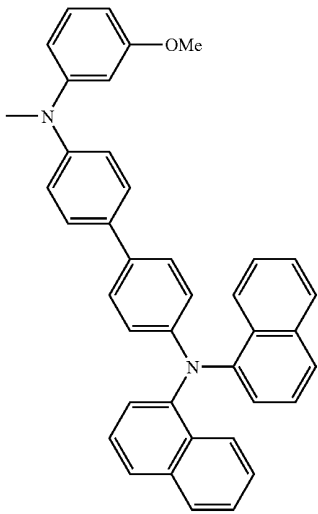

350

-continued

353

5

10

15

20

354

25

30

35

40

45

355

50

55

60

65

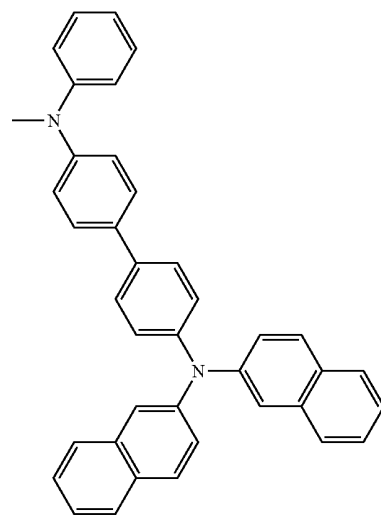
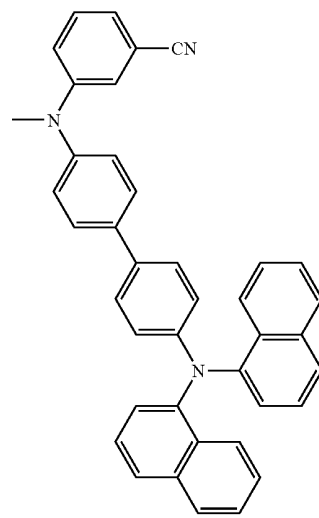
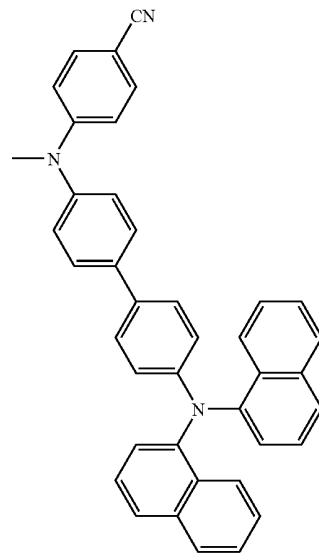

356

357

358

351

-continued

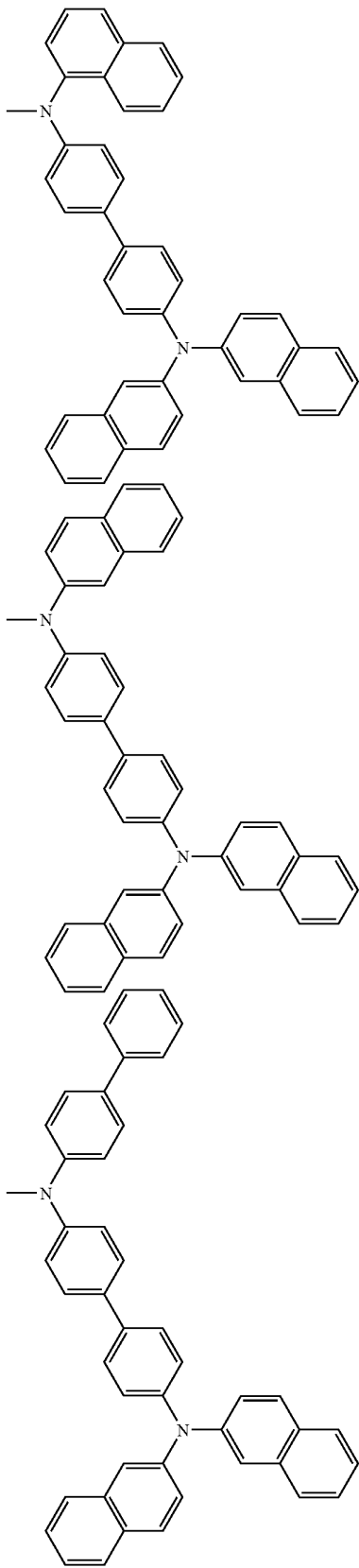

352

-continued

359

362

5

10

15

20

360

363

25

30

35

40

361

45

364

50

55

60

65

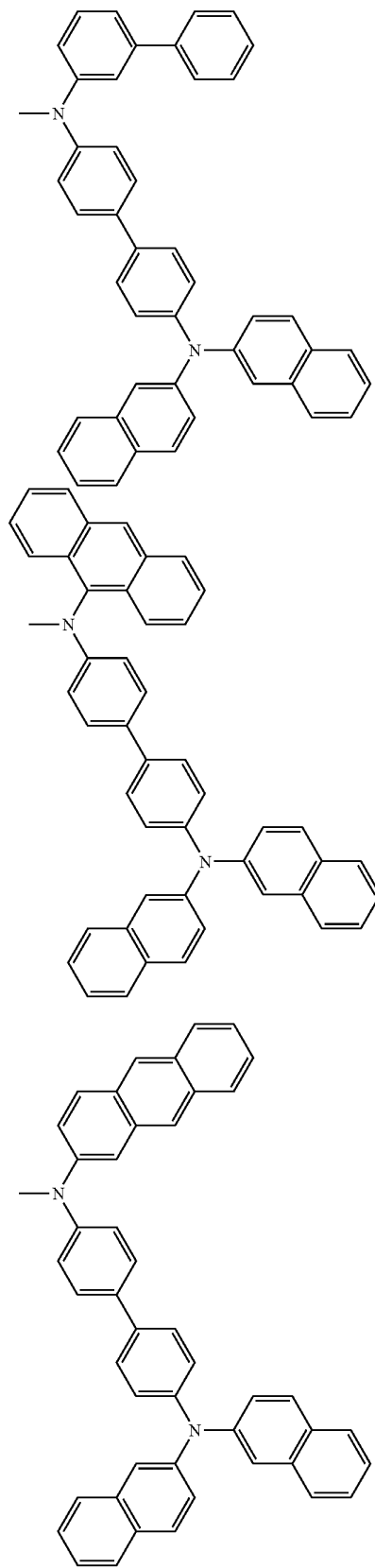

**353**  
-continued

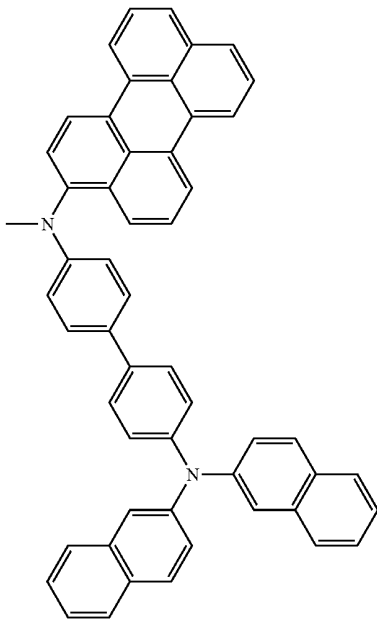
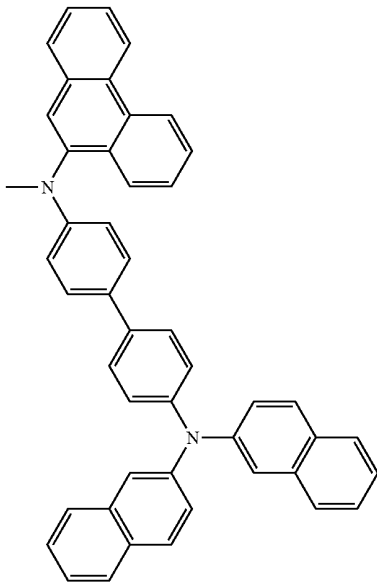

**354**  
-continued

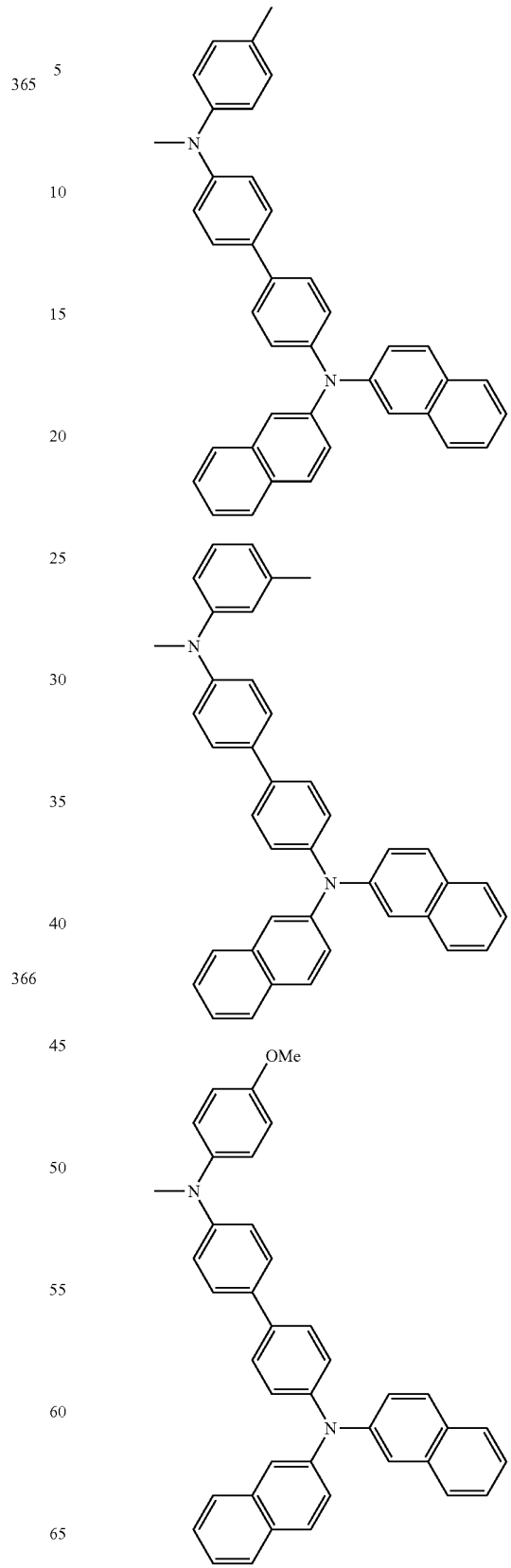

367

368

369

355

-continued

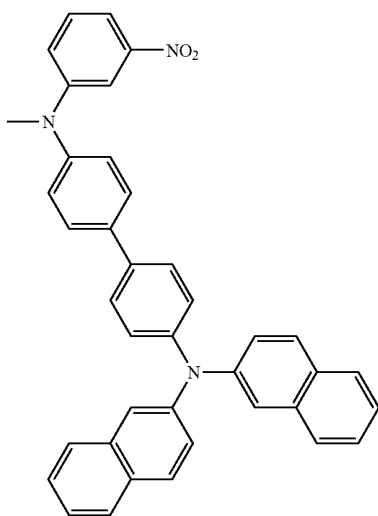
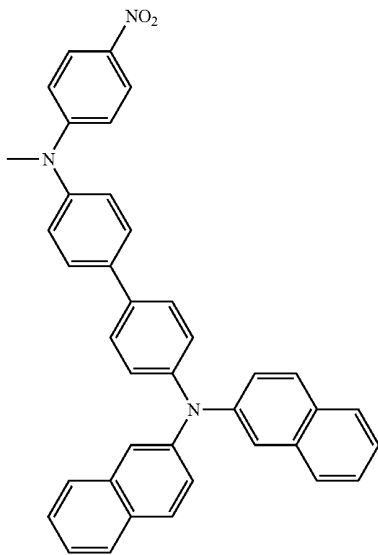
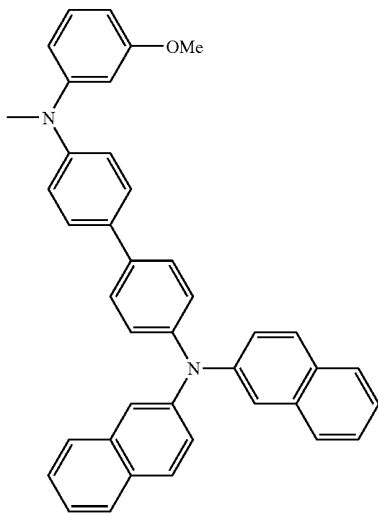

356

-continued

370

373

5

10

15

20

371

374

25

30

35

40

45

375

372

50

55

60

65

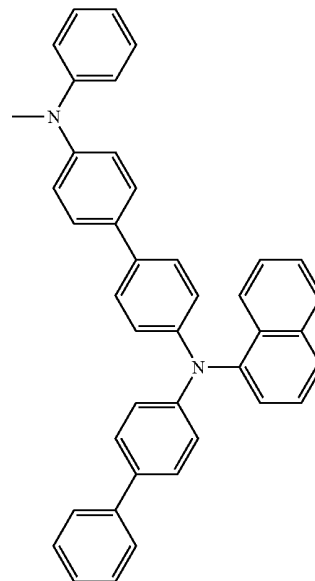
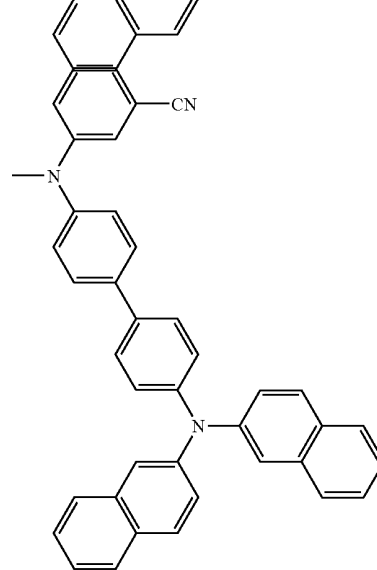
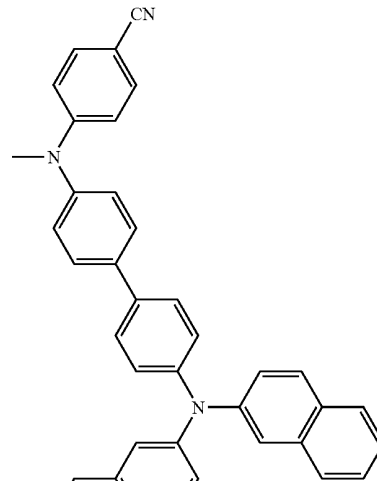

33

-continued

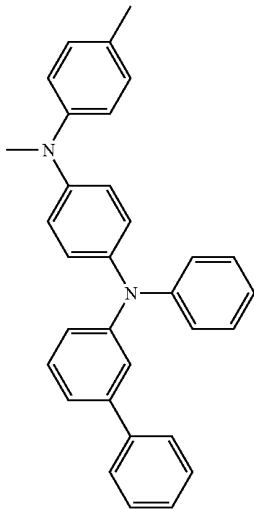
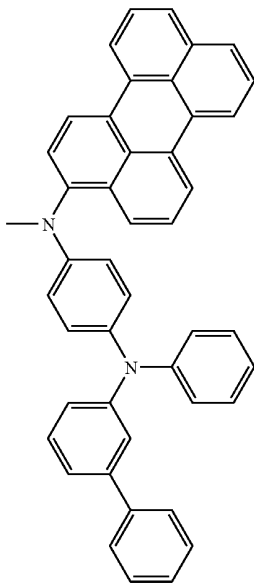
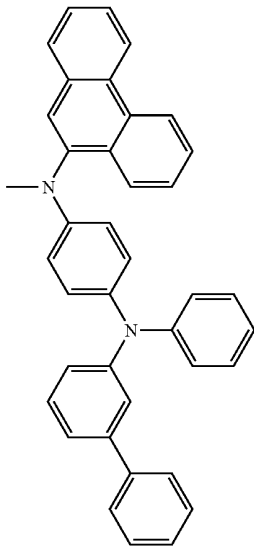

34

-continued

76

5

10

15

20

77

25

30

35

40

45

78

50

55

60

65

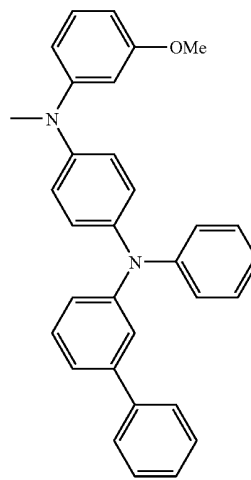
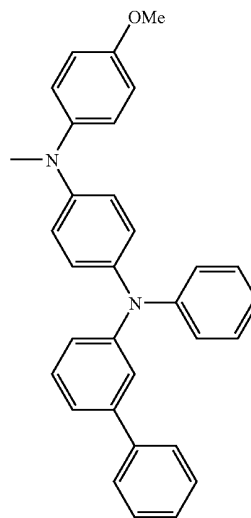
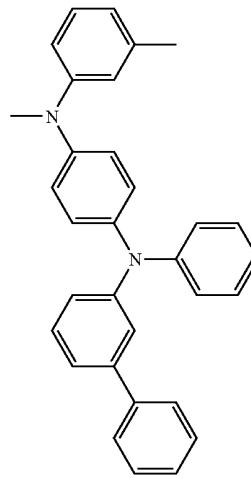

79

80

81

**357**  
-continued

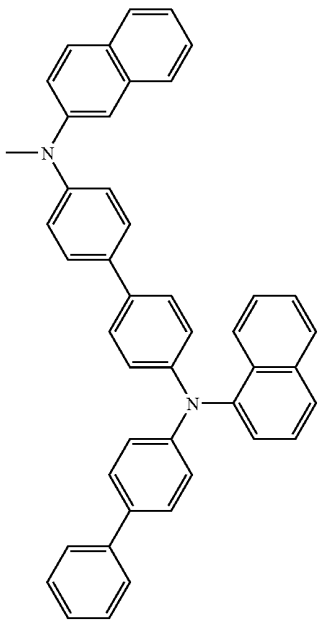
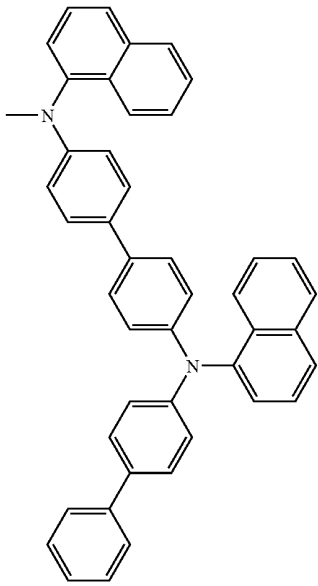

**358**  
-continued

376

5

378

10

15

20

25

30

35

40

377

45

50

55

60

65

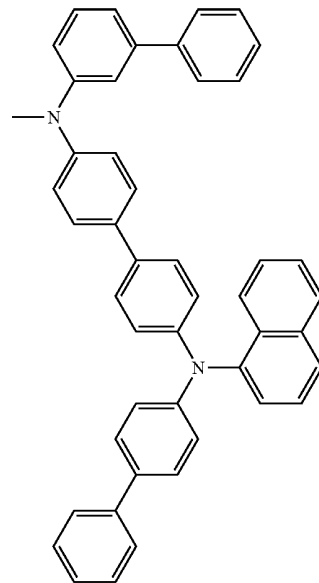
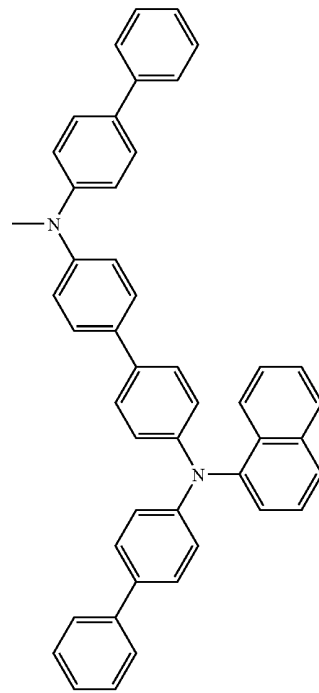

**359**  
-continued

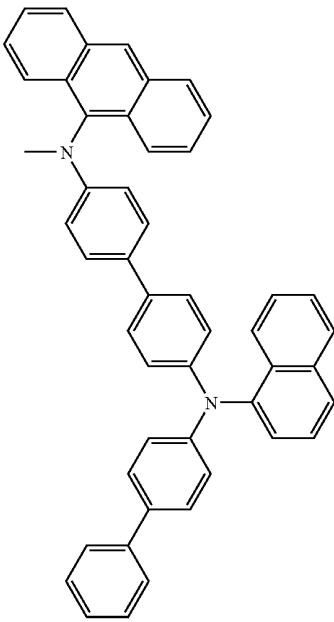

380 5

**360**  
-continued

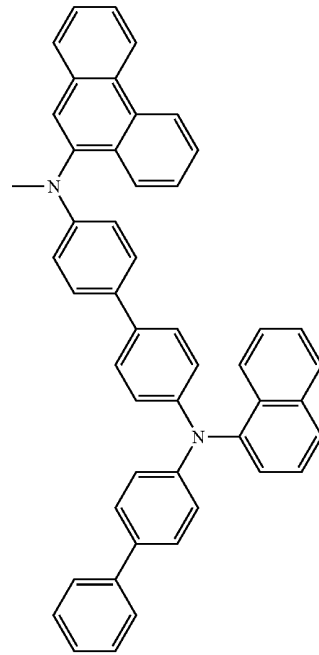

382

10

15

20

25

30

35

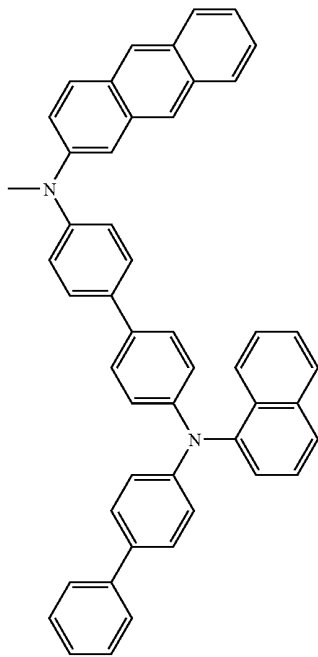

381

45

50

55

60

65

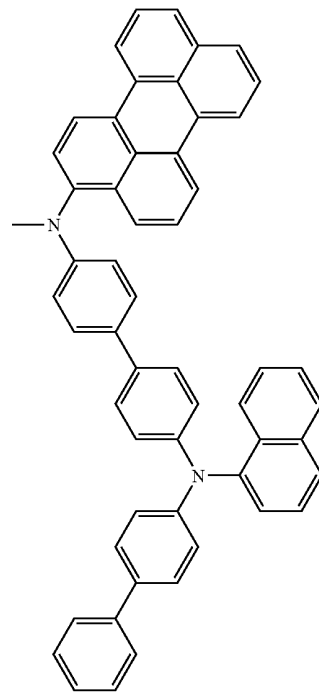

383

**361**  
-continued

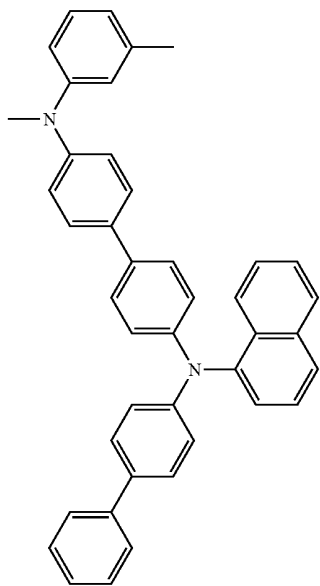
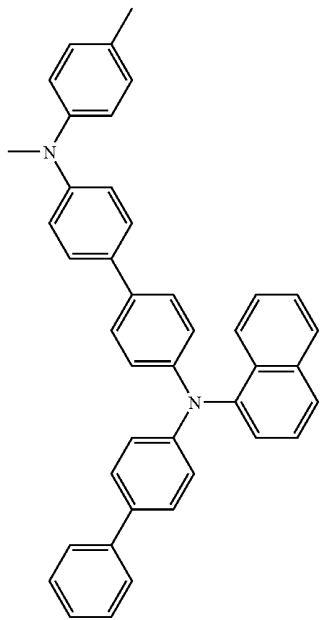

**362**  
-continued

5  
384  
10  
15  
20  
25  
30  
35  
40

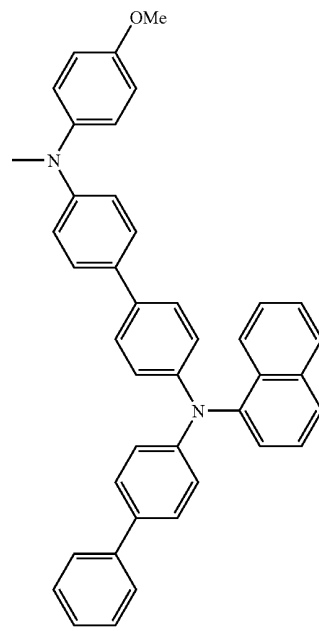

386

385  
45  
50  
55  
60  
65

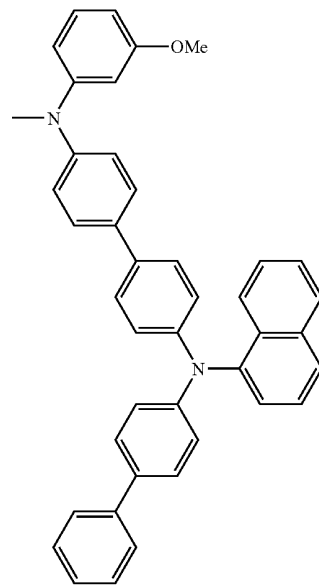

387

**363**  
-continued

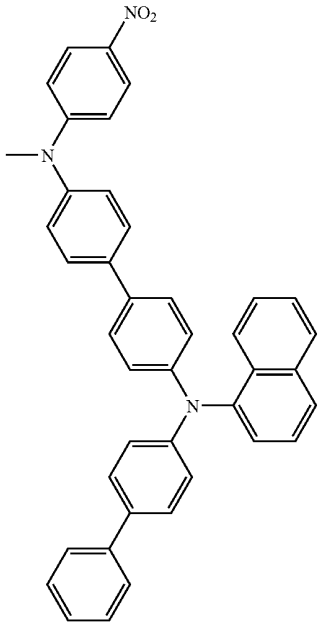

5  
388

**364**  
-continued

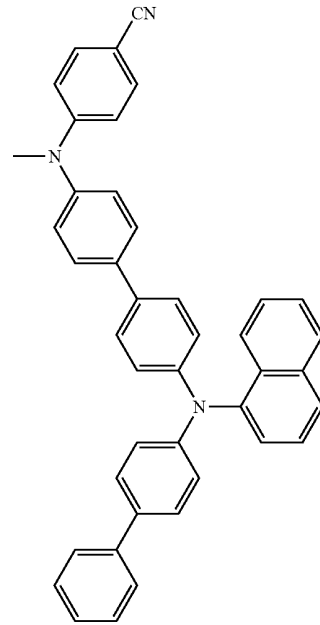

390

10  
15  
20  
25  
30  
35

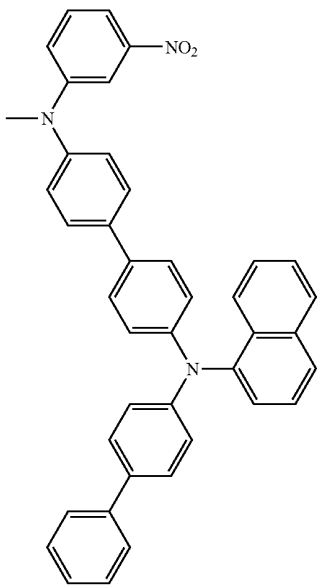

40  
389  
45  
50  
55  
60  
65

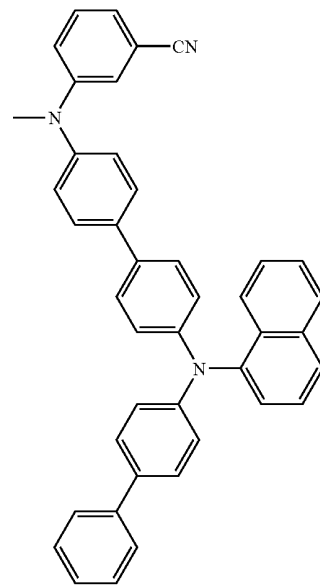

391

**365**  
-continued

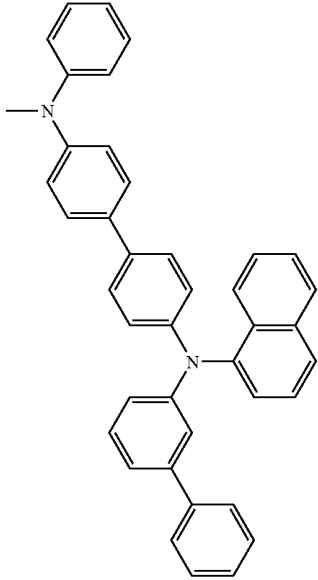

**367**  
-continued

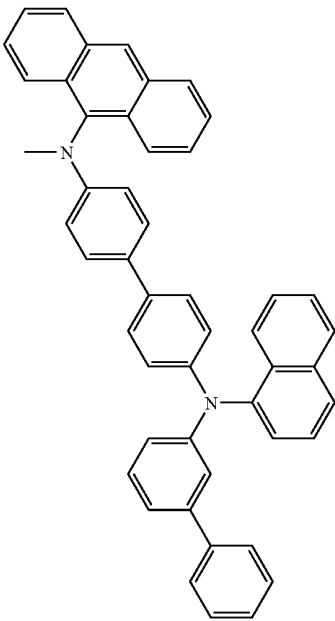
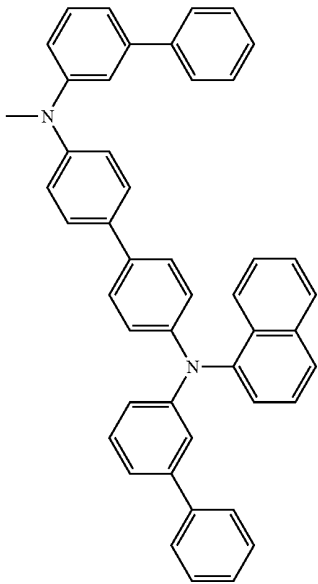

**368**  
-continued

5  
396

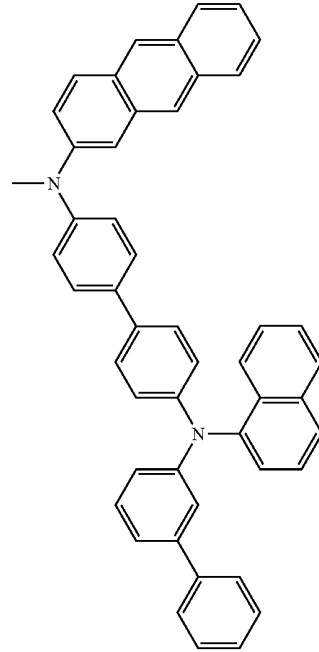

398

10  
15  
20  
25  
30  
35

40  
397

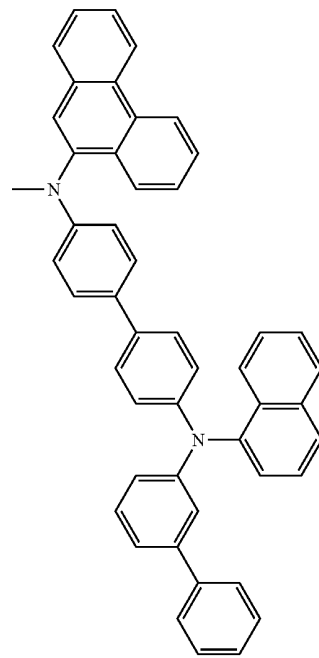

399

45  
50

55  
60

65

**369**  
-continued

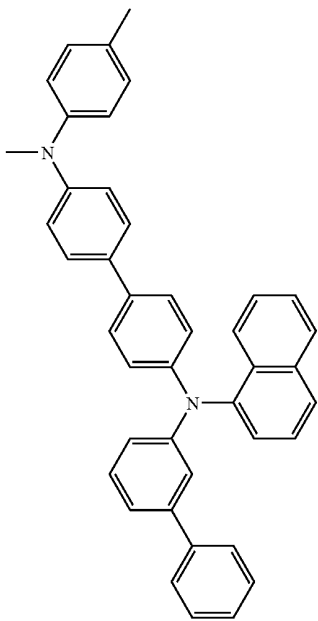
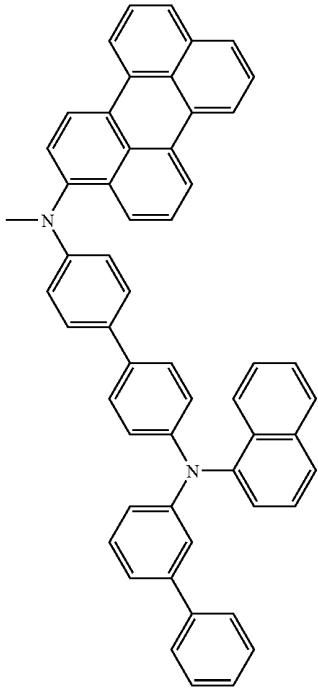

**370**  
-continued

5  
400  
10  
15  
20  
25  
30  
35

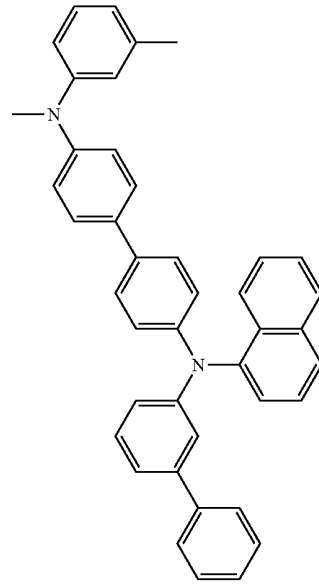

402

401  
45  
50  
55  
60  
65

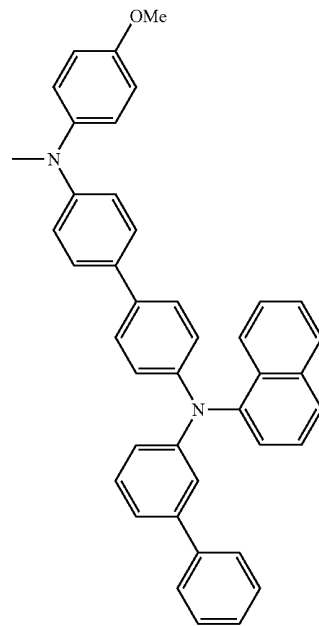

403

**371**  
-continued

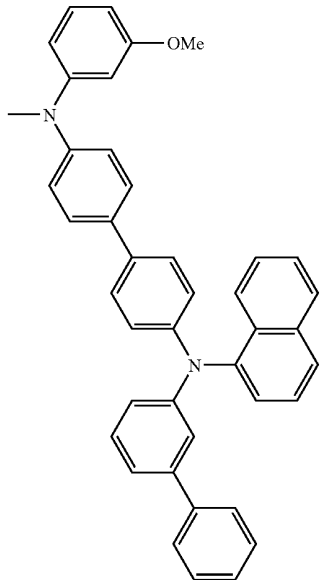

5

404

10

15

20

25

30

35

40

405

45

50

55

60

65

**372**  
-continued

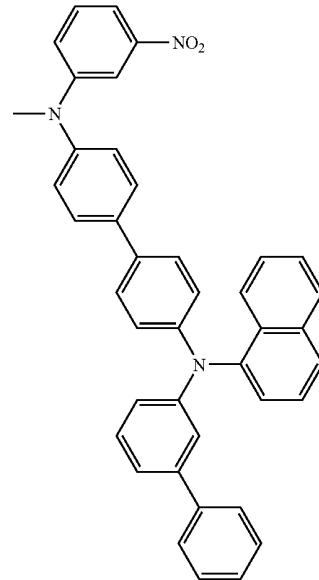

406

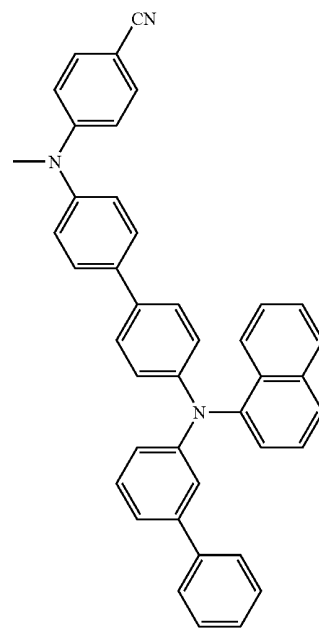
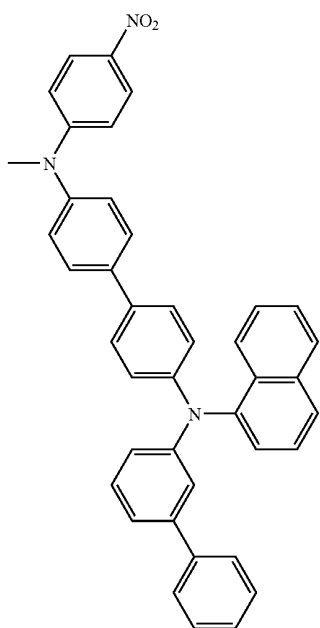

407

373  
-continued

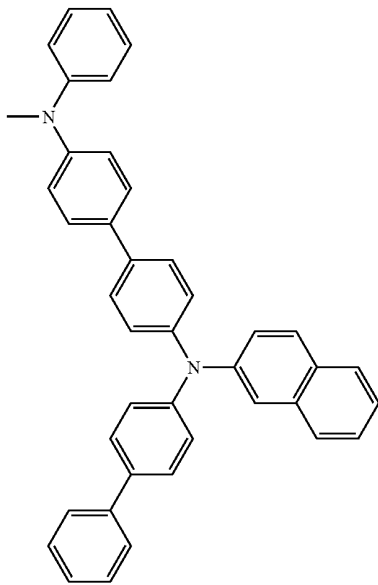
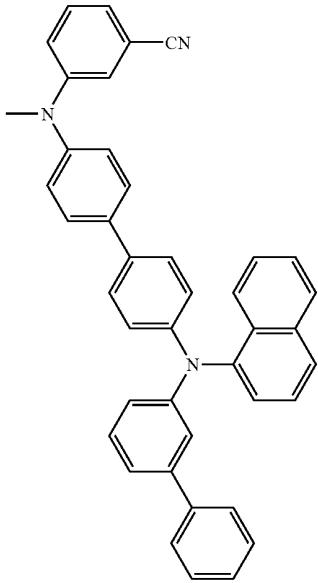

374  
-continued

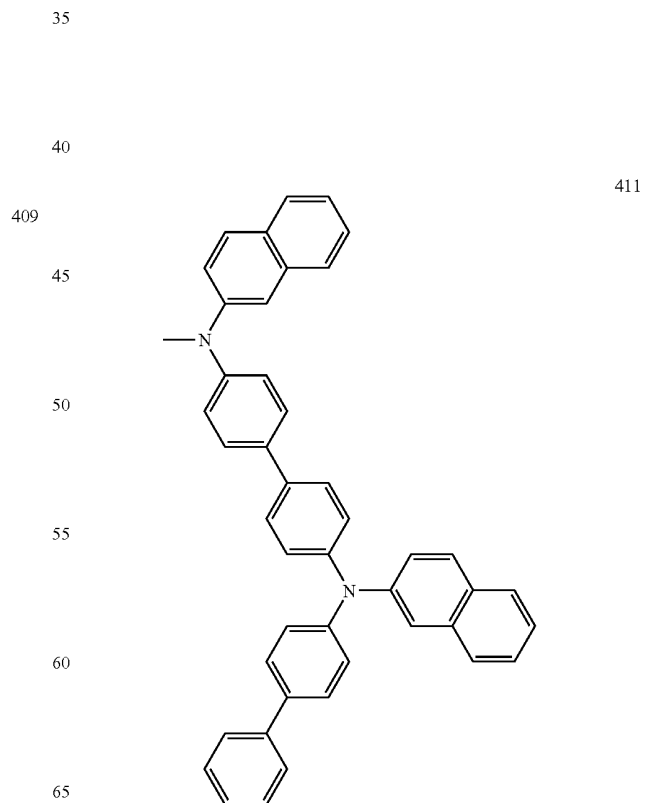
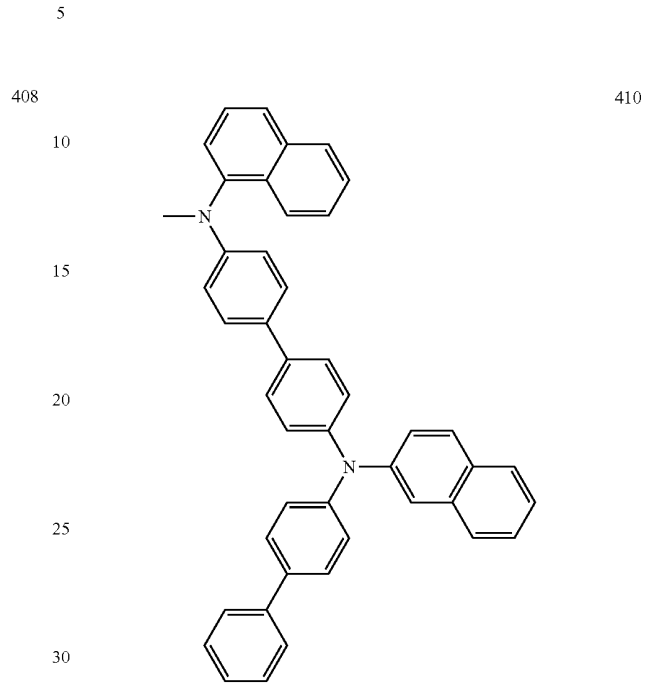

410

411



35

-continued

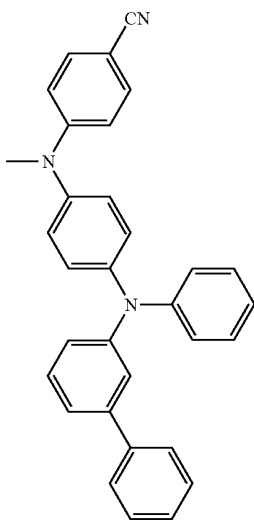
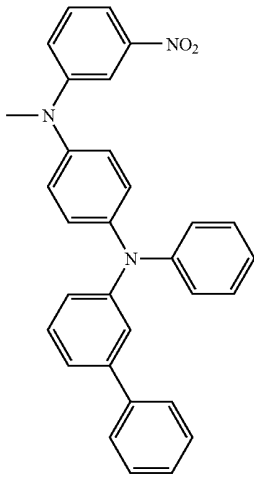
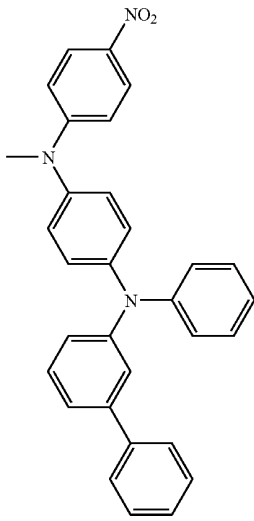

82

5

10

15

20

83

25

30

35

40

45

84

50

55

60

65

36

-continued

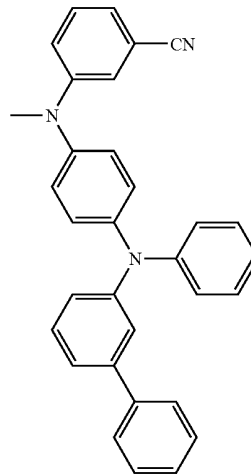

85

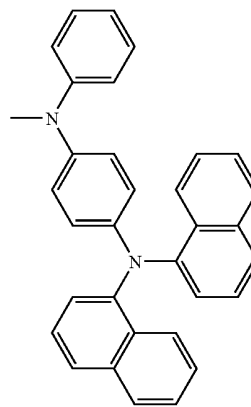

86

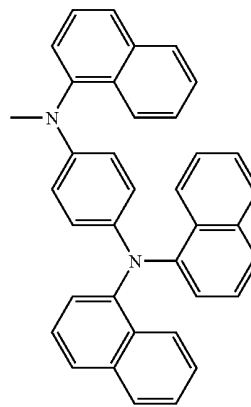

87

377  
-continued

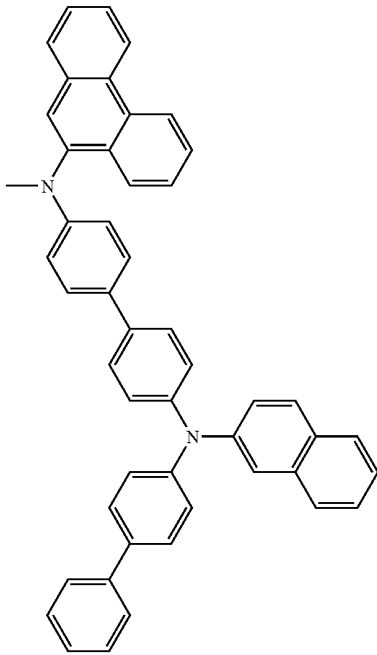

378  
-continued

5  
416  
10  
15  
20  
25  
30  
35

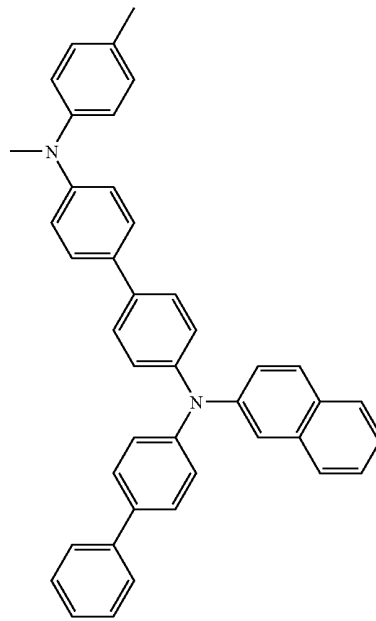

418

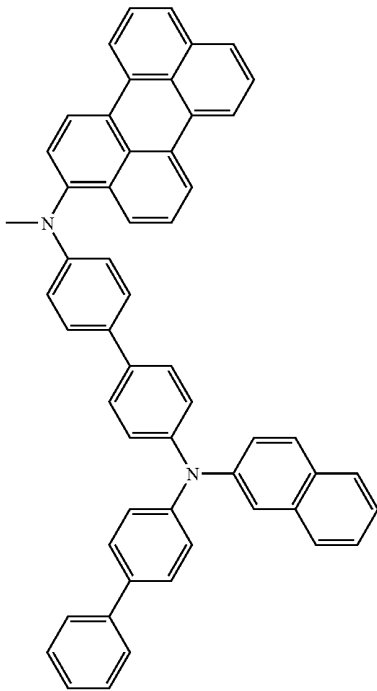

417  
40  
45  
50  
55  
60  
65

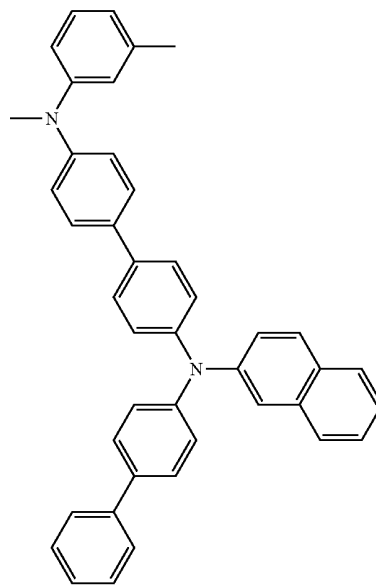

419

**379**  
-continued

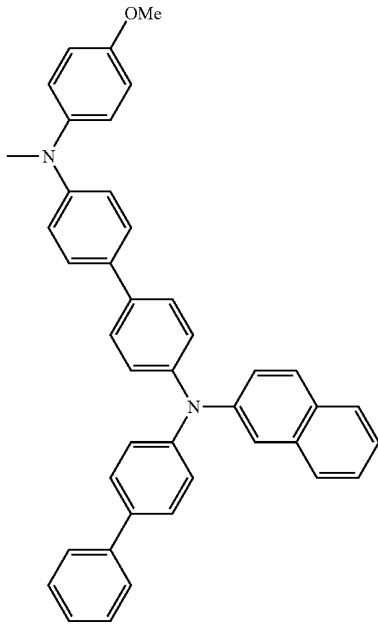

5

420

10

15

20

25

30

35

40

**380**  
-continued

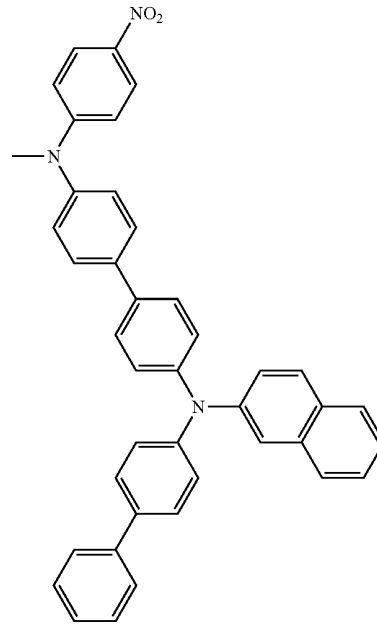

422

421

45

50

55

60

65

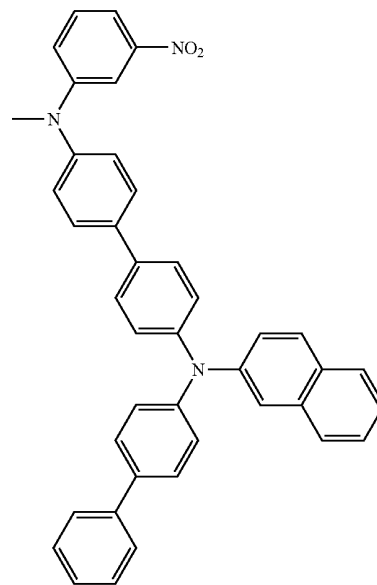
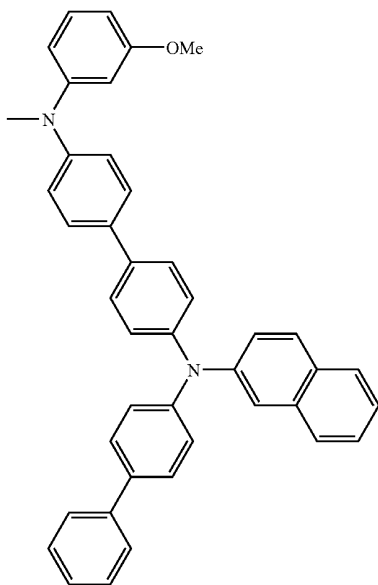

423

**381**  
-continued

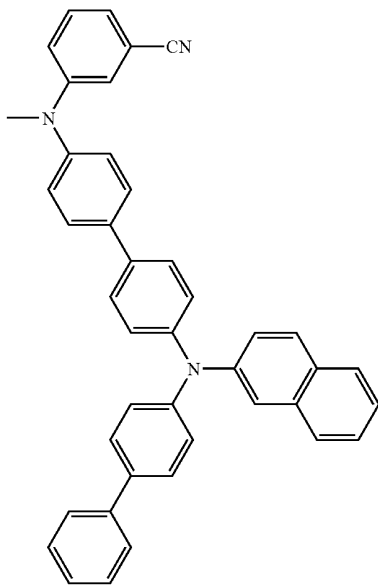
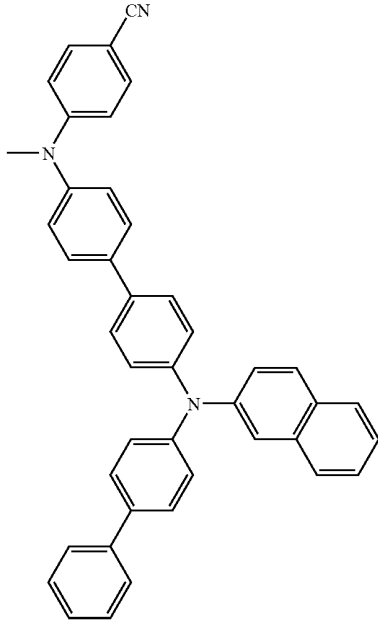

**382**  
-continued

5  
424  
10  
15  
20  
25  
30  
35

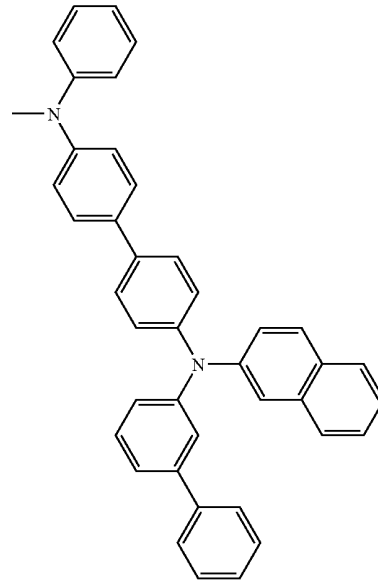

426

40  
425  
45  
50  
55  
60  
65

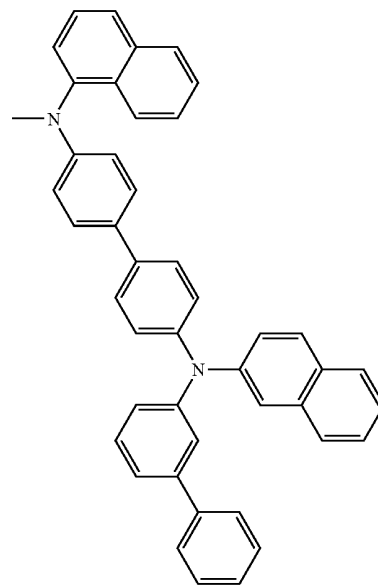

427

**383**  
-continued

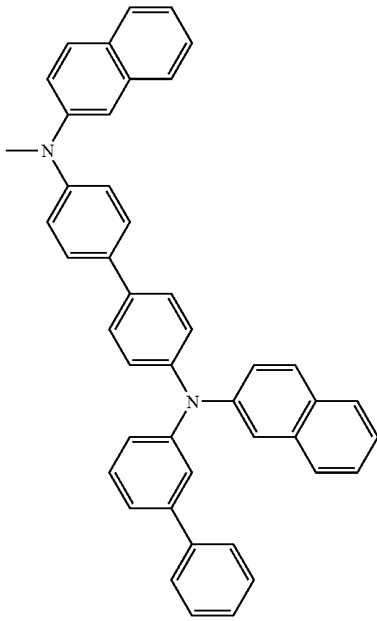

**384**  
-continued

428 5  
10  
15  
20  
25  
30  
35

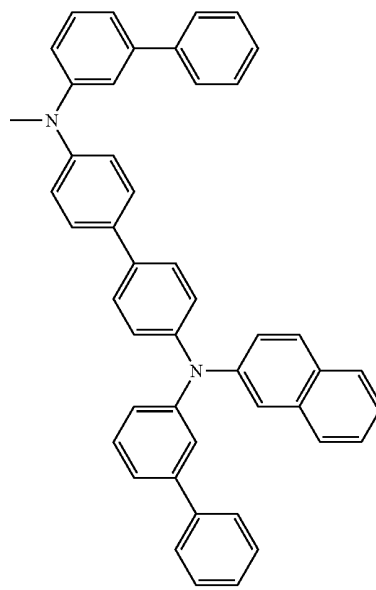

430

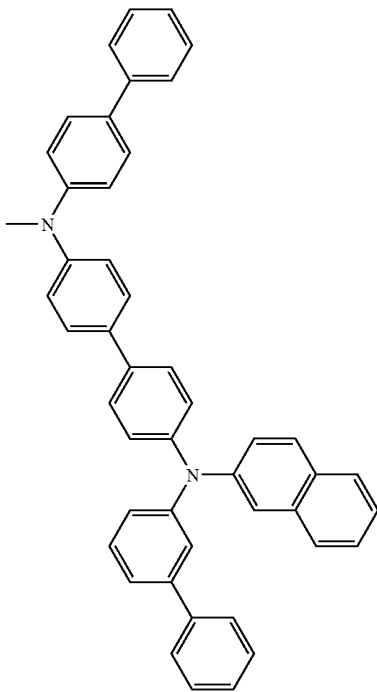

429 40  
45  
50  
55  
60  
65

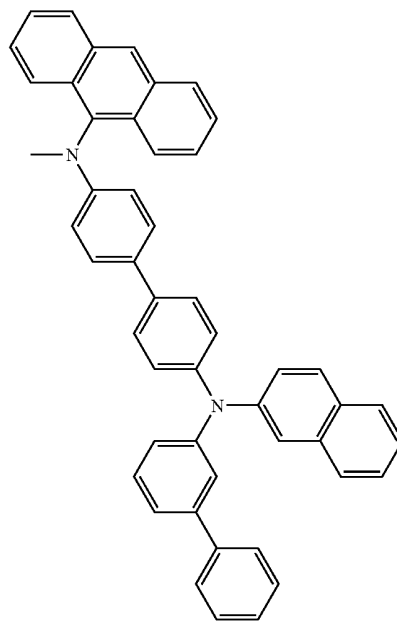

431

**385**  
-continued

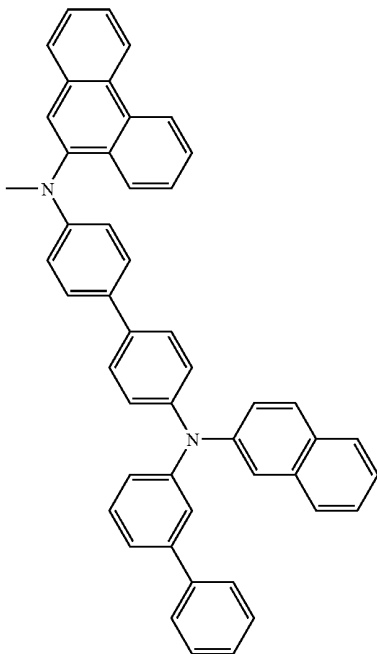
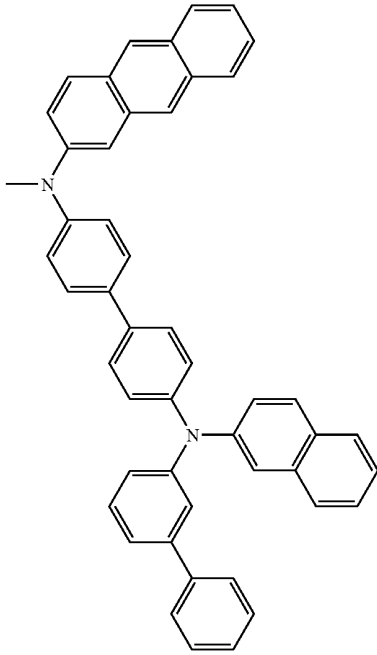

**386**  
-continued

432 <sup>5</sup>

434

10

15

20

25

30

35

40

433

435

45

50

55

60

65

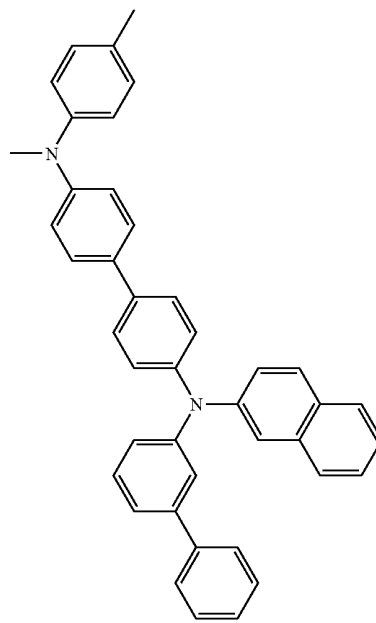
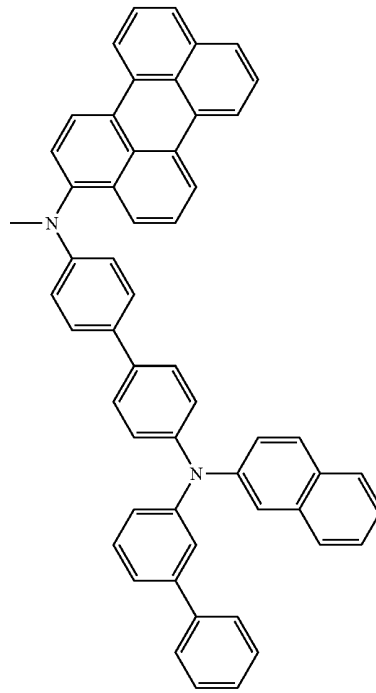

**387**  
-continued

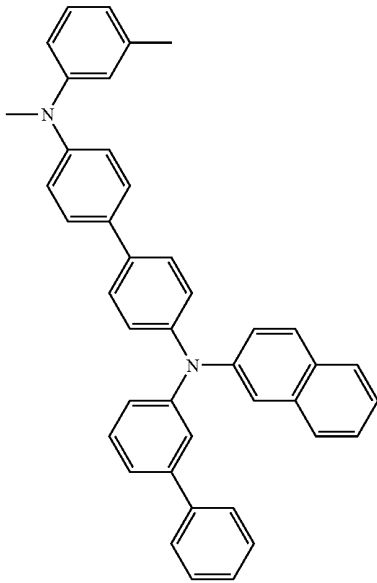

5  
436  
10  
15  
20  
25  
30  
35

**388**  
-continued

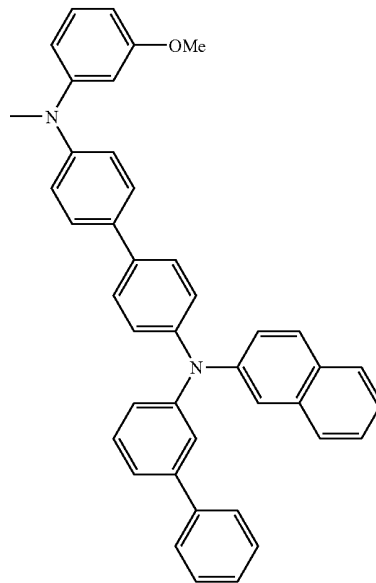

438

40  
437  
45  
50  
55  
60  
65

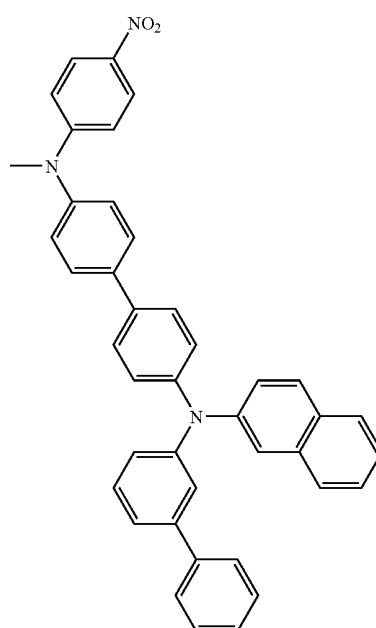
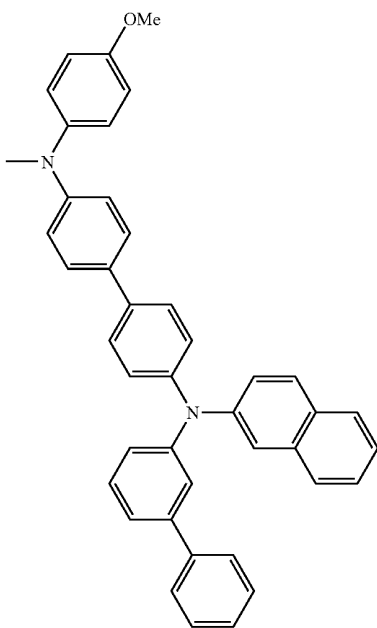

439

**389**  
-continued

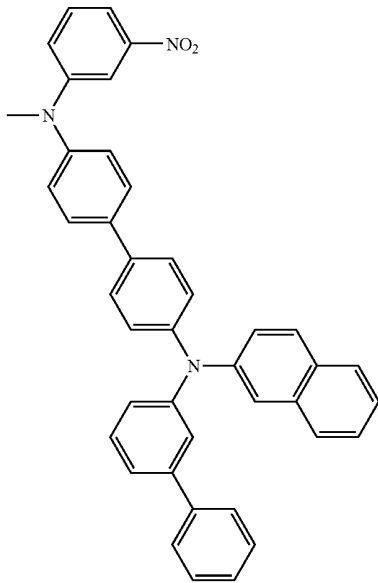

440

5

10

15

20

25

30

35

40

441

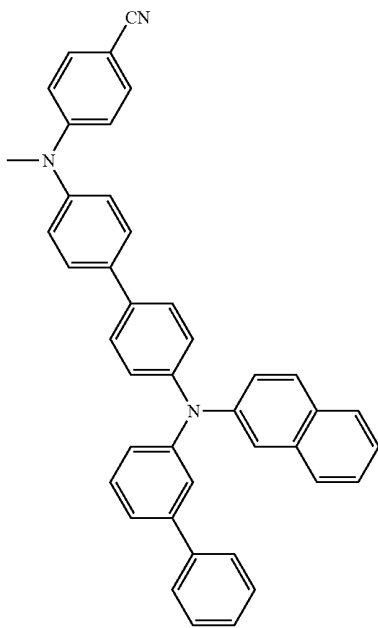

45

50

55

60

65

**390**  
-continued

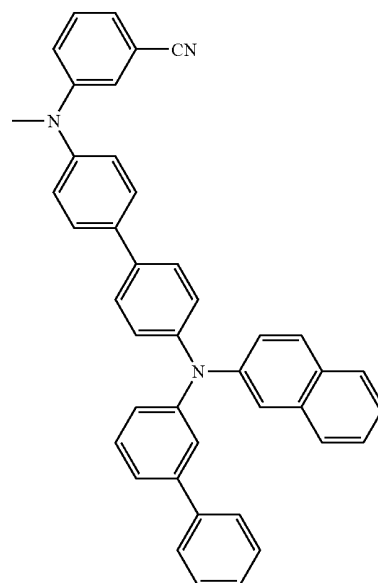

442

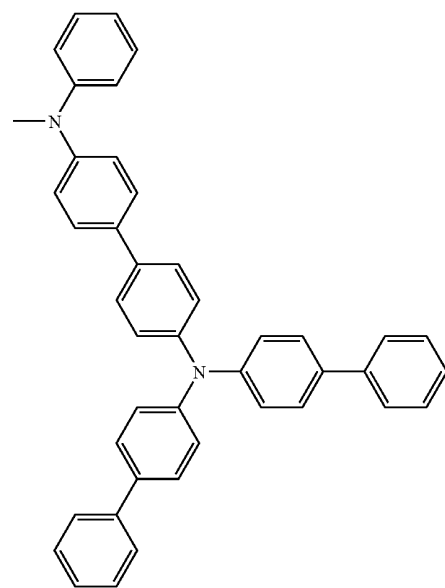

443

**391**  
-continued

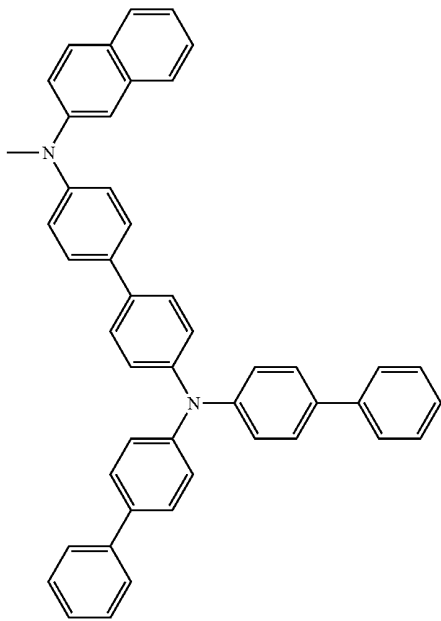
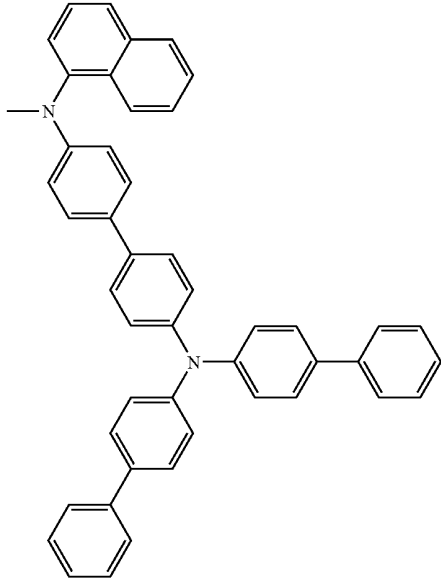

**392**  
-continued

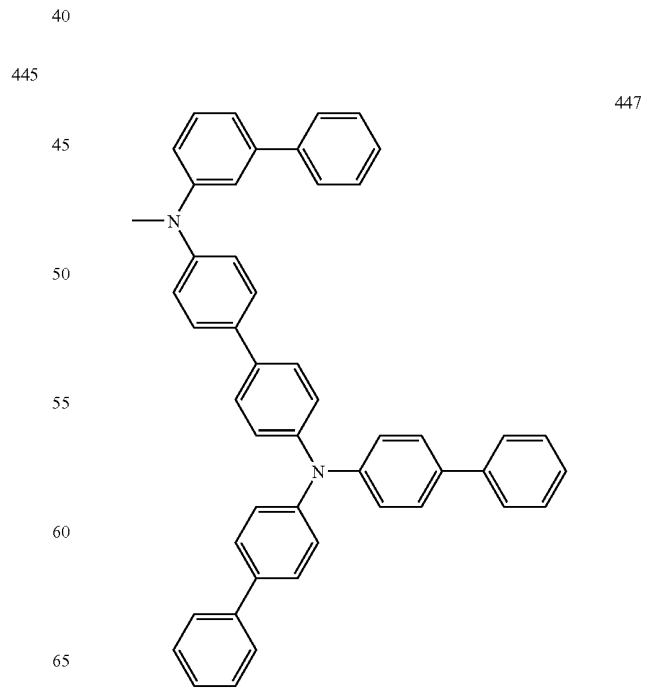
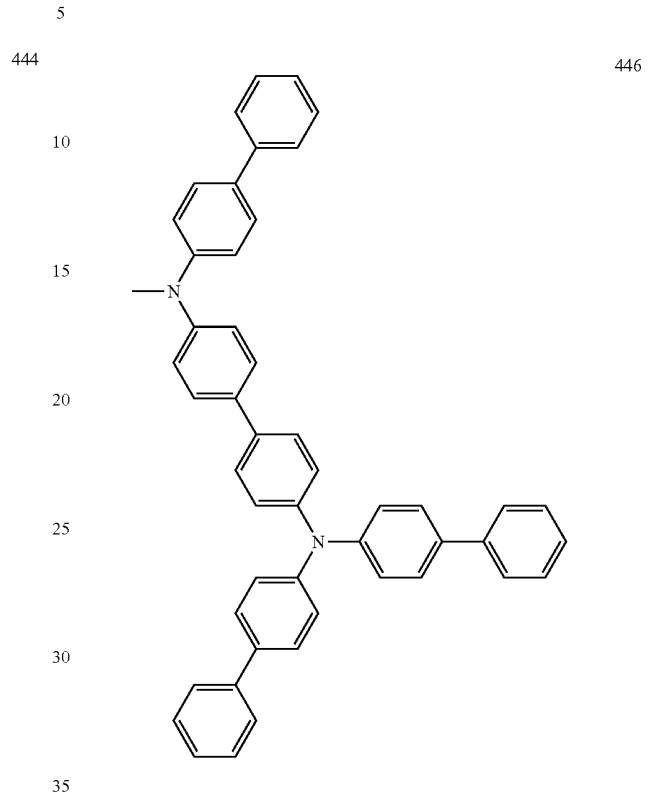

**393**  
-continued

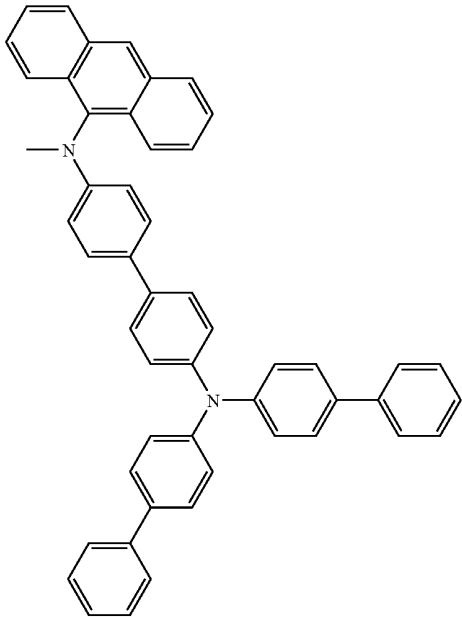

448

5

10

15

20

25

30

35

**394**  
-continued

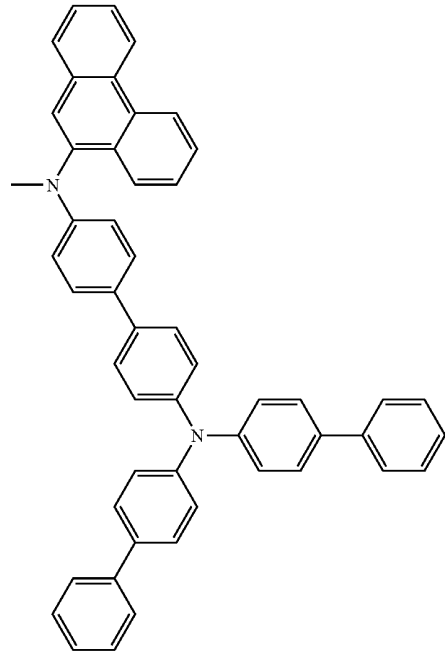

450

40

449

45

50

55

60

65

451

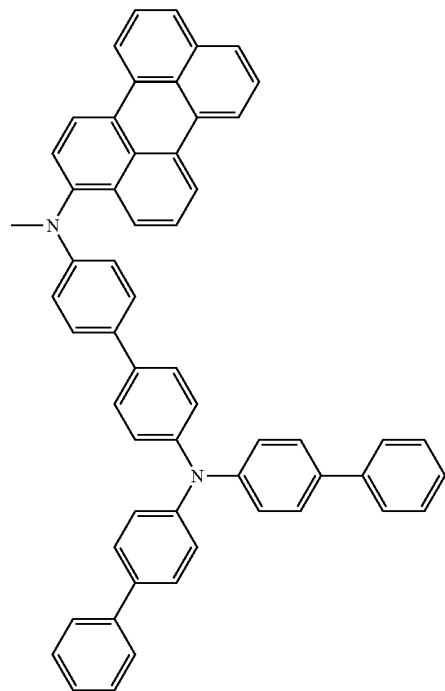
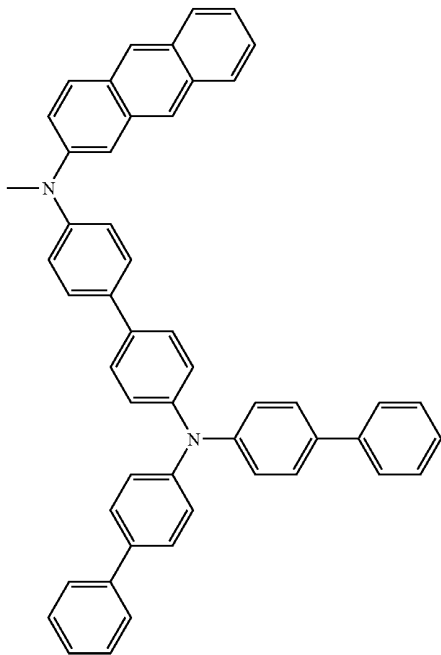

**395**  
-continued

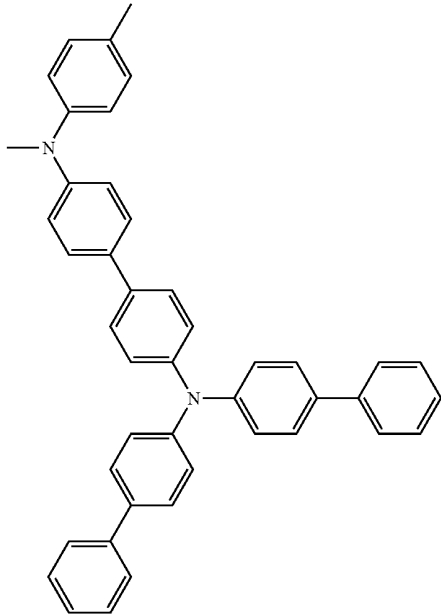

5  
452  
10  
15  
20  
25  
30  
35  
40

**396**  
-continued

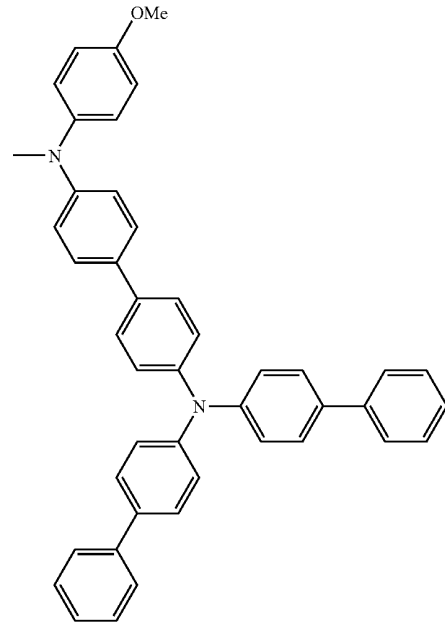

454

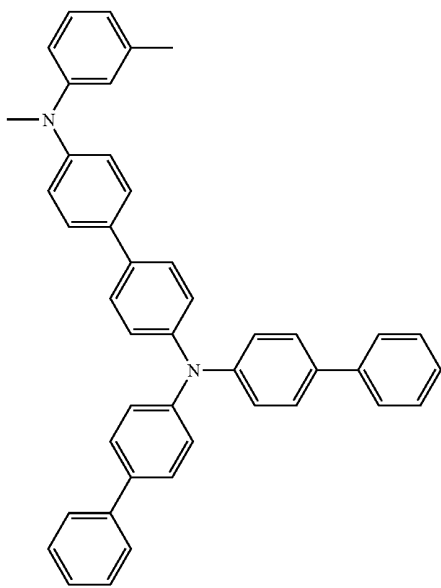

453  
45  
50  
55  
60  
65

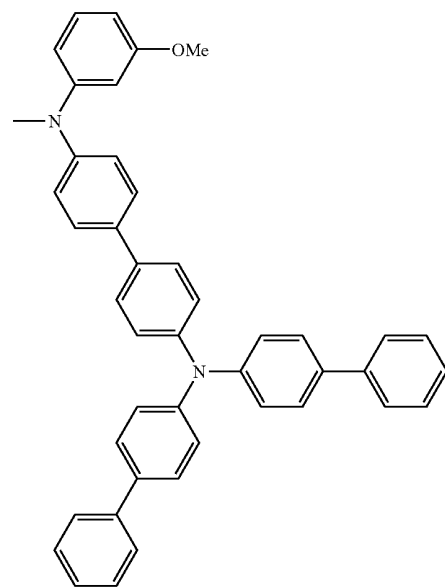

455

# COMPOUNDS AND ORGANIC LIGHT EMITTING DIODE USING THE SAME

## TECHNICAL FIELD

The present invention relates to new compounds which are capable of significantly improving a lifespan, efficiency, electrochemical stability and thermal stability of an organic light emitting diode, and an organic light emitting diode in which the compound is contained in an organic compound layer.

This application is a national phase application of International Application No. PCT/KR2007/006178 filed on Dec. 3, 2007, which claims priority to Korean Patent Application No. 10-2006-0120557 filed on Dec. 1, 2006, both of which are incorporated by reference for all purposes, as if fully set forth herein.

## BACKGROUND ART

An organic light emission phenomenon is an example of a conversion of current into visible rays through an internal process of a specific organic molecule. The organic light emission phenomenon is based on the following mechanism. When organic material layers are interposed between an anode and a cathode, if voltage is applied between the two electrodes, electrons and holes are injected from the cathode and the anode into the organic material layer. The electrons and the holes which are injected into the organic material layer are recombined to form an exciton, and the exciton is reduced to a bottom state to emit light. An organic light emitting diode which is based on the above mechanism typically comprises a cathode, an anode, and organic material layer(s), for example, organic material layers including a hole injection layer, a hole transport layer, a light emitting layer, and an electron transport layer, interposed therebetween.

The materials used in the organic light emitting diode are mostly pure organic materials or complexes of organic material and metal. The material used in the organic light emitting diode may be classified as a hole injection material, a hole transport material, a light emitting material, an electron transport material, or an electron injection material, according to its use. In connection with this, an organic material having a p-type property, which is easily oxidized and is electrochemically stable when it is oxidized, is mostly used as the hole injection material or the hole transport material. Meanwhile, an organic material having an n-type property, which is easily reduced and is electrochemically stable when it is reduced, is used as the electron injection material or the electron transport material. As the light emitting layer material, an organic material having both p-type and n-type properties is preferable, which is stable when it is oxidized and when it is reduced. Also a material having high light emission efficiency for conversion of the exciton into light when the exciton is formed is preferable.

In addition, it is preferable that the material used in the organic light emitting diode further have the following properties.

First, it is preferable that the material used in the organic light emitting diode have excellent thermal stability. The reason is that joule heat is generated by movement of electric charges in the organic light emitting diode. NPB (N,N-di(naphthalene-1-yl)-N,N-diphenyl-benzidine), which has recently been used as the hole transport layer material, has a glass transition temperature of 100° C. or lower, thus it is difficult to apply to an organic light emitting diode requiring a high current.

Second, in order to produce an organic light emitting diode that is capable of being actuated at low voltage and has high efficiency, holes and electrons which are injected into the organic light emitting diode must be smoothly transported to a light emitting layer, and must not be released out of the light

emitting layer. To achieve this, a material used in the organic light emitting diode must have a proper band gap and a proper HOMO (highest occupied molecular orbital) or LUMO (lowest unoccupied molecular orbital) energy levels. A LUMO energy level of PEDOT (poly(3,4-ethylenedioxythiophene)); PSS (poly(styrenesulfonate)), which is currently used as a hole transport material of an organic light emitting diode produced using a solution coating method, is lower than that of an organic material used as a light emitting layer material, thus it is difficult to produce an organic light emitting diode having high efficiency and a long lifespan.

Moreover, the material used in the organic light emitting diode must have excellent chemical stability, electric charge mobility, and interfacial characteristic with an electrode or an adjacent layer. That is to say, the material used in the organic light emitting diode must be little deformed by moisture or oxygen. Furthermore, proper hole or electron mobility must be assured so as to balance densities of the holes and of the electrons in the light emitting layer of the organic light emitting diode to maximize the formation of excitons. Additionally, it has to be able to have a good interface with an electrode including metal or metal oxides so as to assure stability of the device.

Accordingly, there is a need to develop an organic material having the above-mentioned requirements in the art.

## DISCLOSURE OF INVENTION

### Technical Problem

Therefore, an object of the present inventions is to provide a new compound which is capable of satisfying conditions required of a material usable for an organic light emitting diode, for example, a proper energy level, electrochemical stability, and thermal stability, and which has a chemical structure capable of playing various roles required in the organic light emitting diode, depending on a substituent group, and an organic light emitting diode containing the same.

### Technical Solution

The present invention provides a new compound represented by the following Formula 1.

[Formula 1]

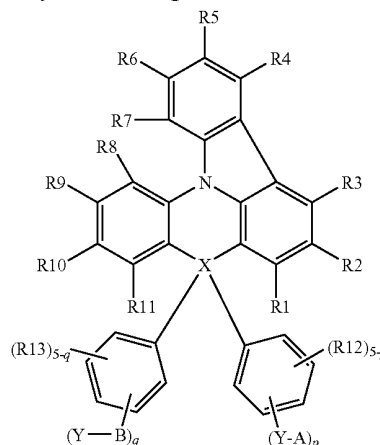

wherein, X is C or Si,

Ys may be the same or different from each other, and may be each independently directly connected to each other; bivalent aromatic hydrocarbons; bivalent aromatic hydrocarbons which are substituted with at least one substituent group selected from the group consisting of nitro, nitrile, halogen,

**37**  
-continued

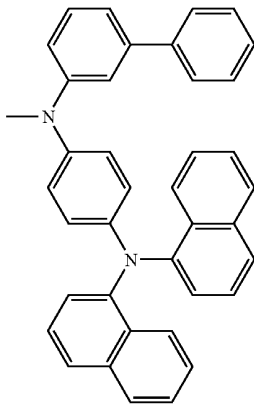
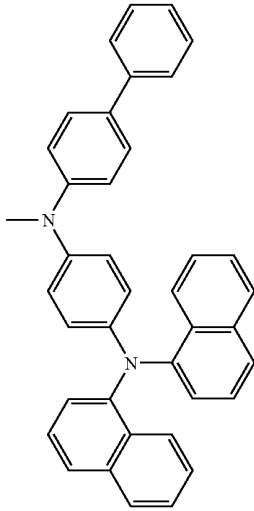
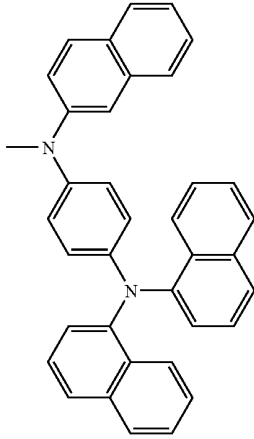

**38**  
-continued

88 5

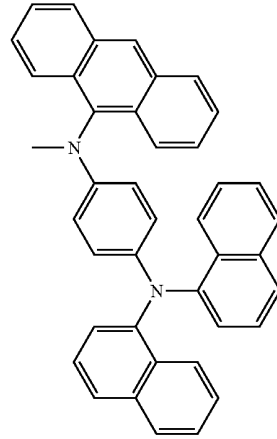

10

15

20

25  
89

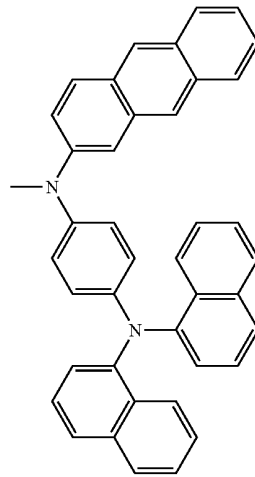

30

35

40

45

50  
90

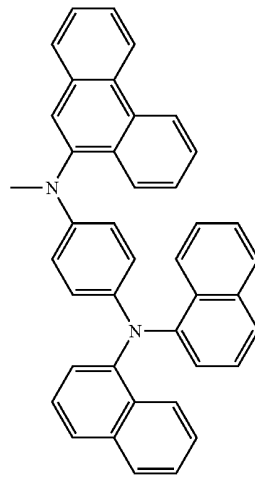

55

60

65

91

92

93

**397**  
-continued

**398**  
-continued

5

456

458

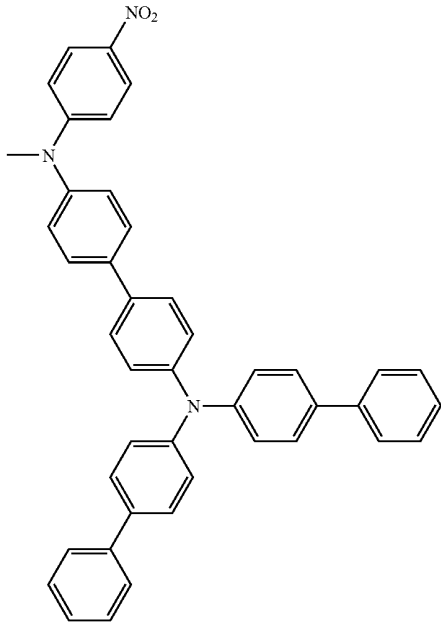

10

15

20

25

30

35

40

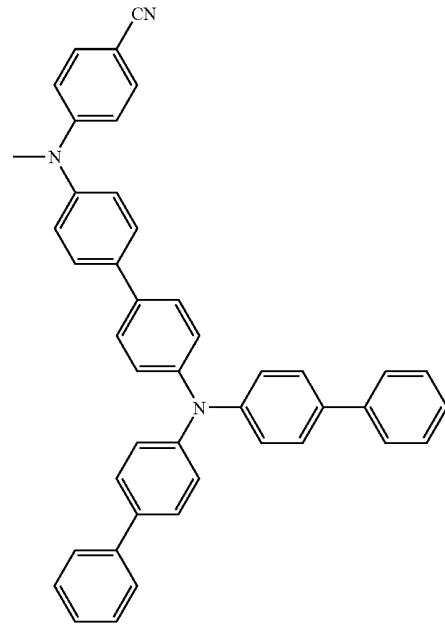

457

459

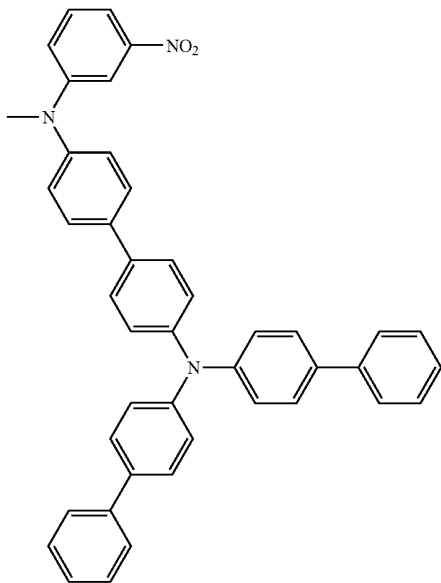

45

50

55

60

65

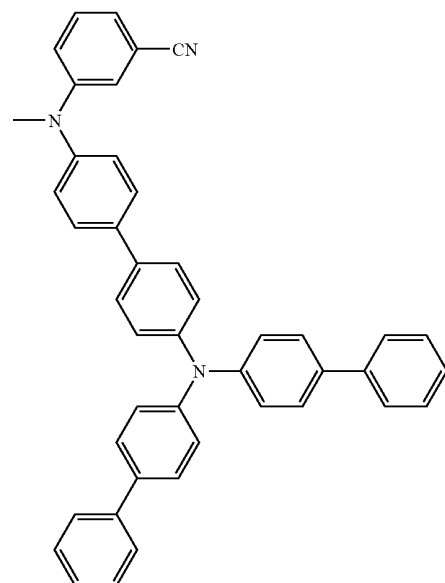

**399**  
-continued

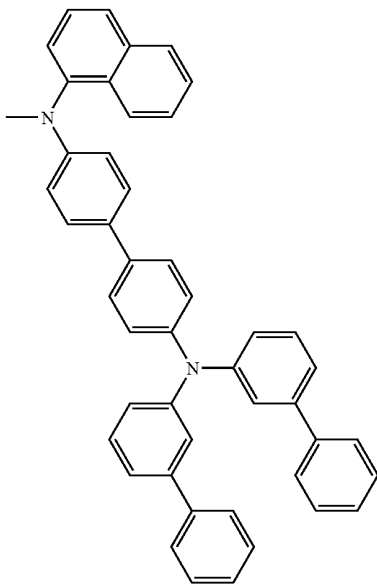
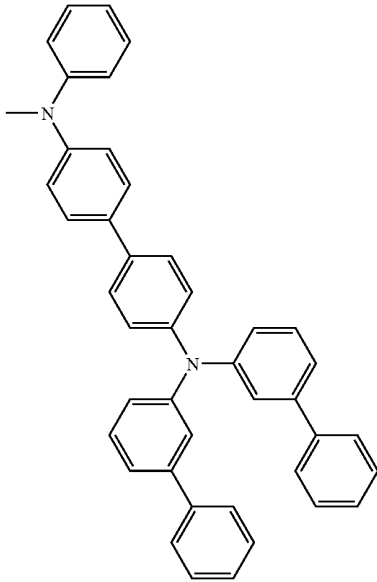

**400**  
-continued

5  
460  
10  
15  
20  
25  
30  
35

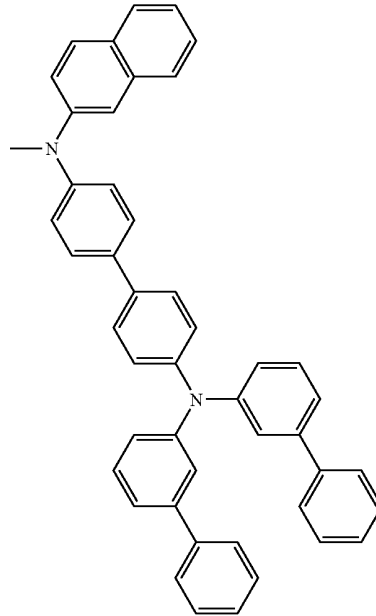

462

40  
461  
45  
50  
55  
60  
65

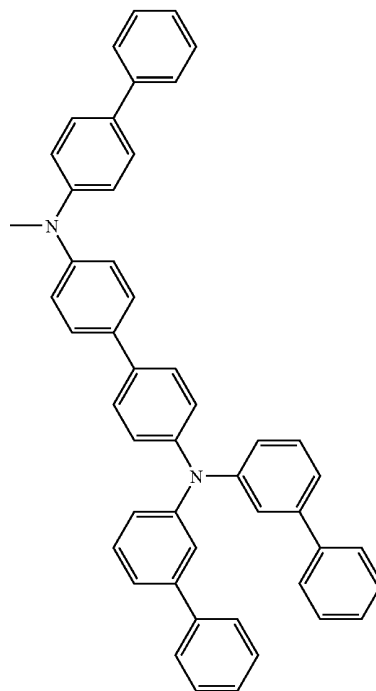

463



**403**  
-continued

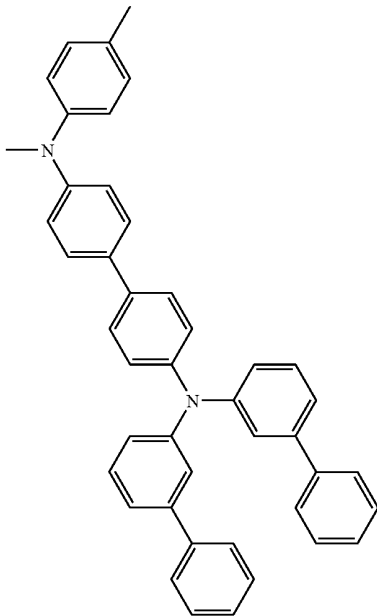
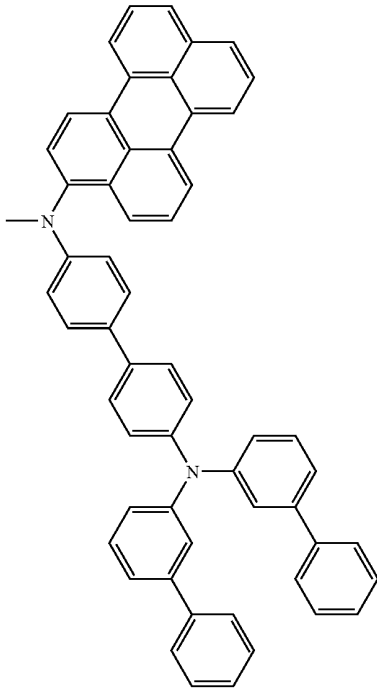

**404**  
-continued

468 <sup>5</sup>

470

10

15

20

25

30

35

40

469

471

45

50

55

60

65

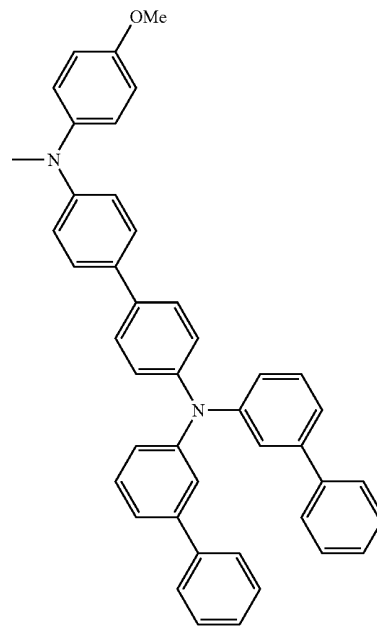
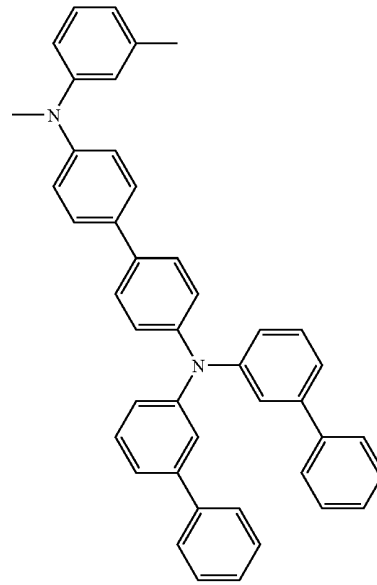

**405**  
-continued

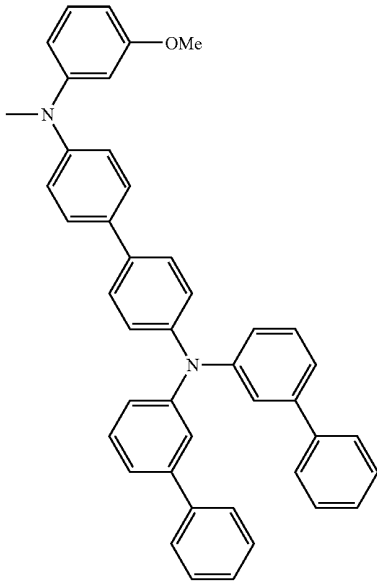

**406**  
-continued

5

474

472

10

15

20

25

30

35

40

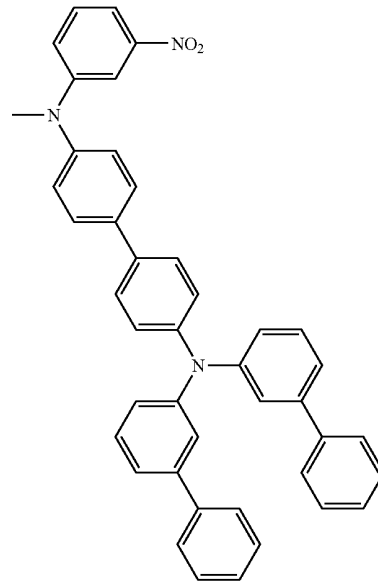

473

475

45

50

55

60

65

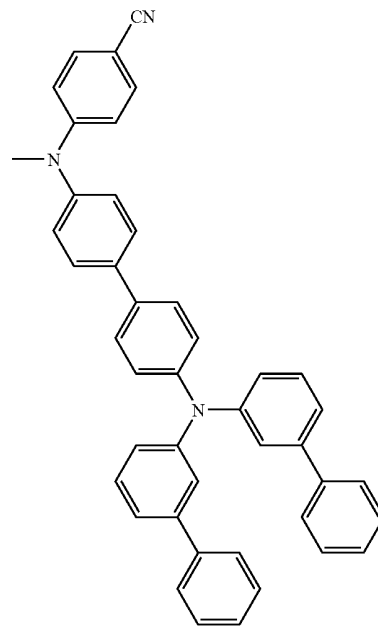
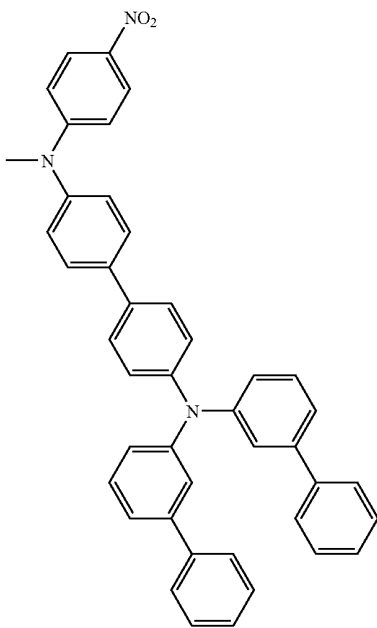

**407**  
-continued

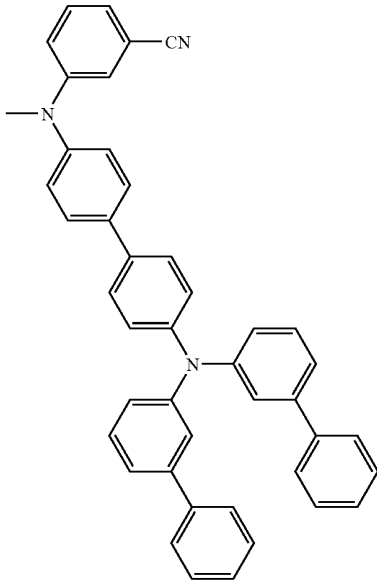

476

5

10

15

20

25

477

35

40

478

45

50

479

60

65

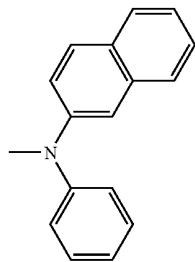
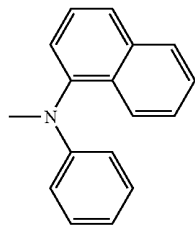
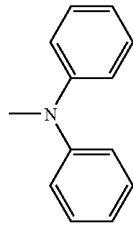

**408**  
-continued

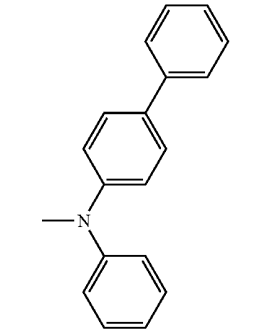

480

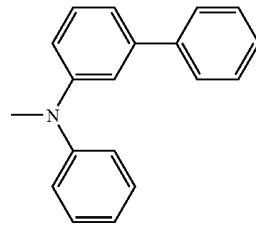

481

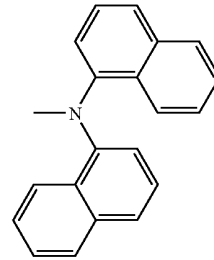

482

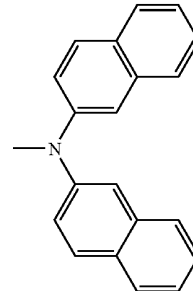

483

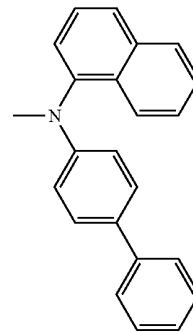

484

409

-continued

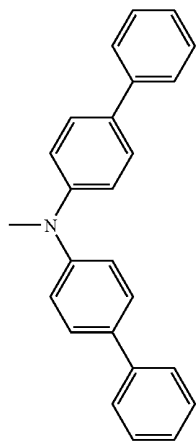
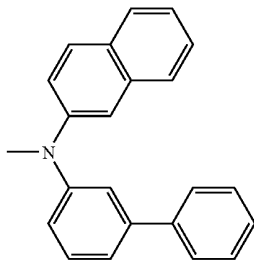
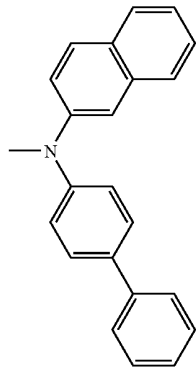
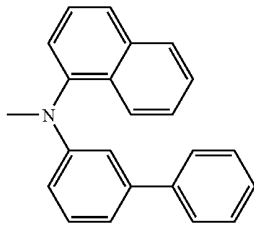

410

-continued

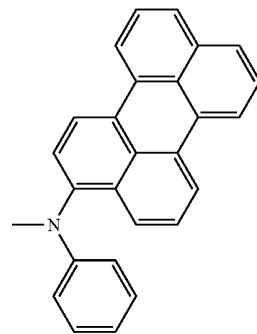
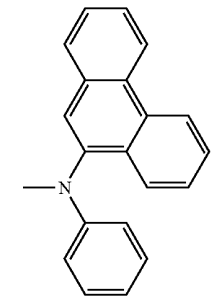
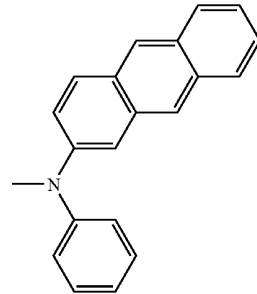
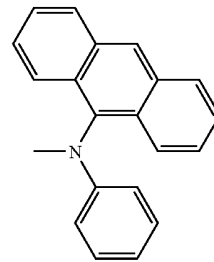
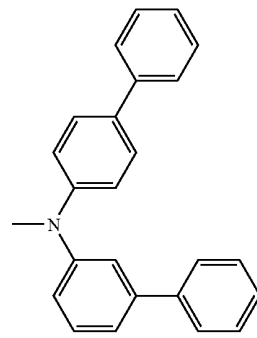

485

5

10

486

15

20

25

30

487

35

40

45

488

50

55

60

65

489

490

491

492

493

**411**

-continued

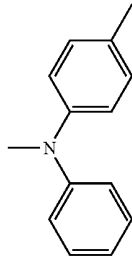

494

5

10

15

495

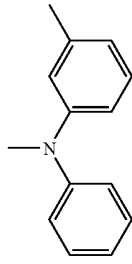

20

25

496

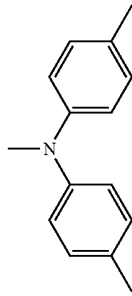

30

35

40

497

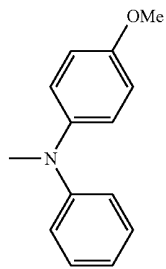

45

50

55

498

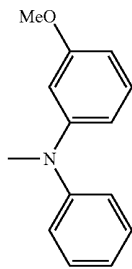

60

65

**412**

-continued

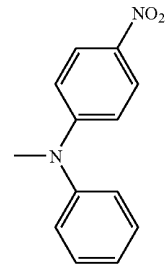

499

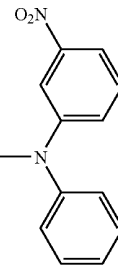

500

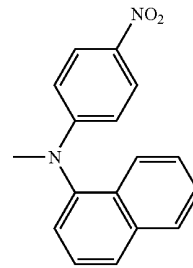

501

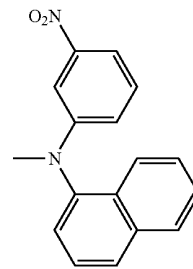

502

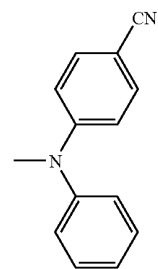

503

**413**

-continued

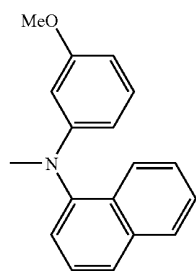
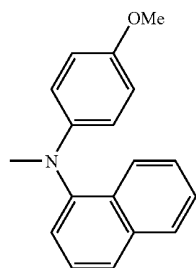
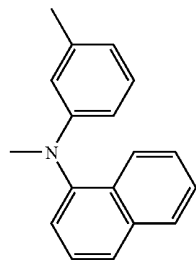
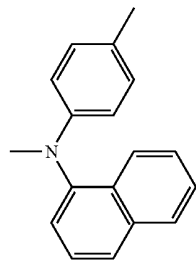
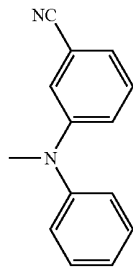

**414**

-continued

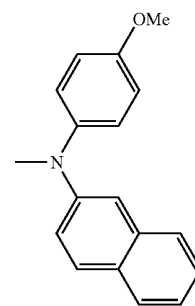
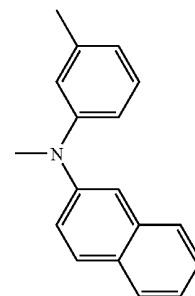
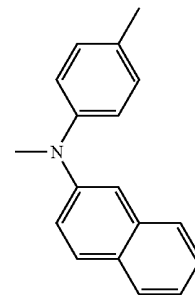
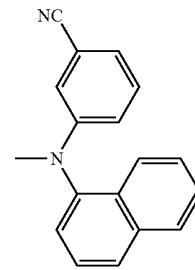
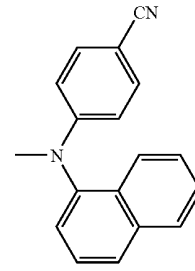

415

-continued

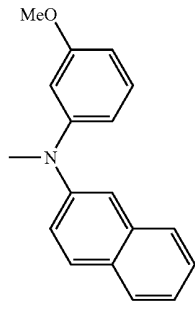

514

5

10

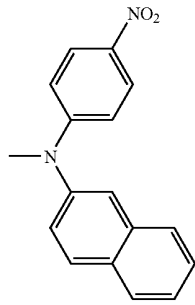

515 15

20

25

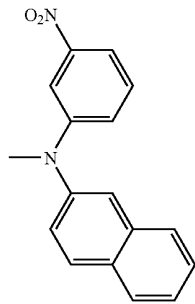

516

30

35

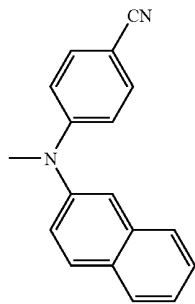

517 40

45

50

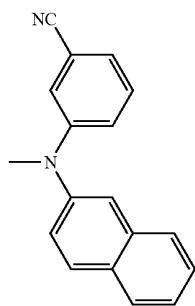

518 55

60

65

416

-continued

519

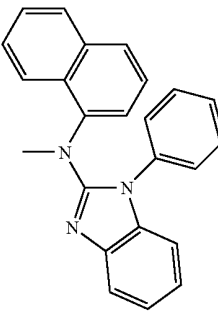
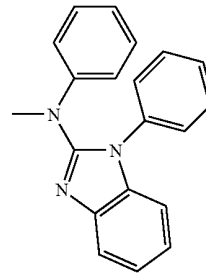

520

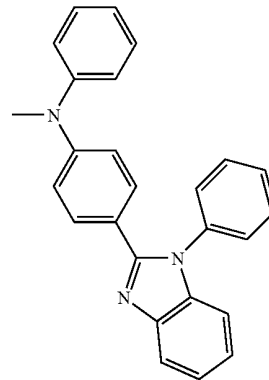

521

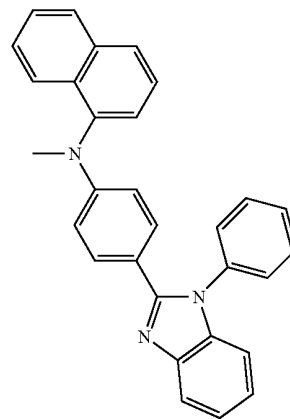

522

**39**  
-continued

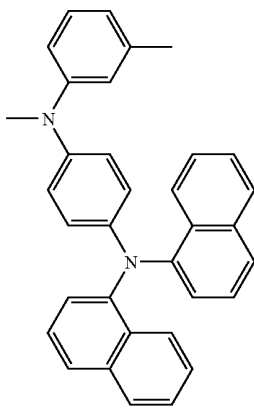
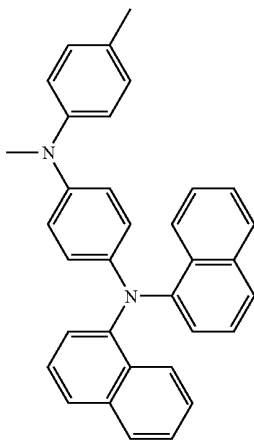
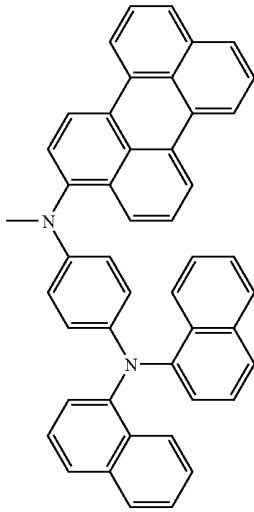

**40**  
-continued

94 5

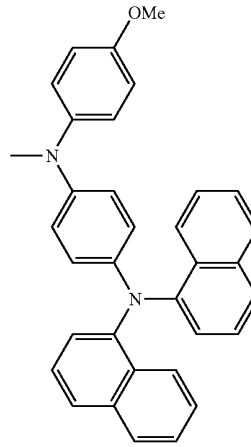

97

10

15

20

25

95

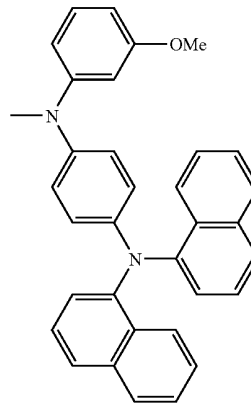

98

30

35

40

45

96

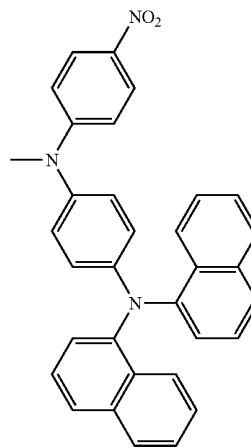

99

50

55

60

65

417

-continued

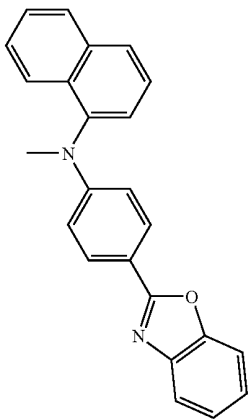
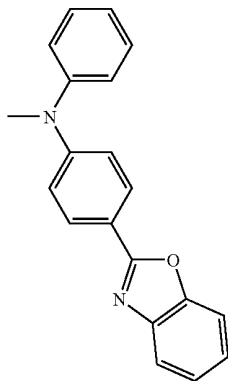
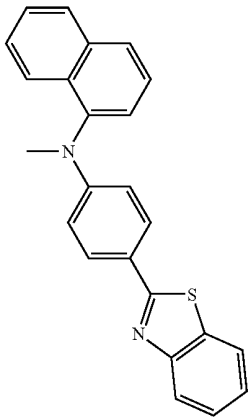
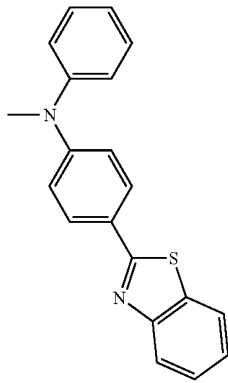

418

-continued

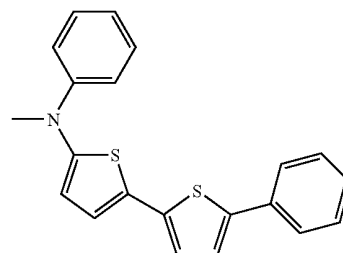
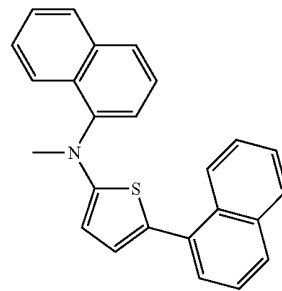
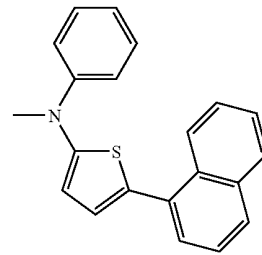
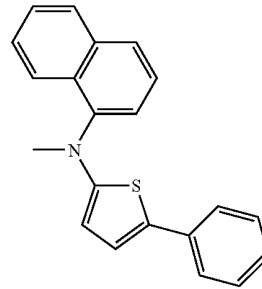
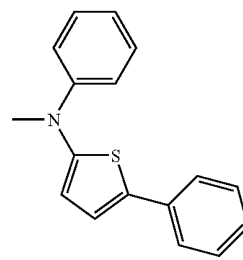

419

-continued

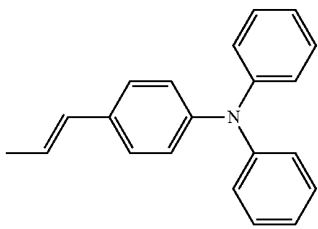
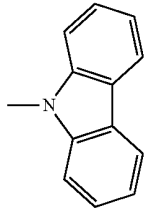
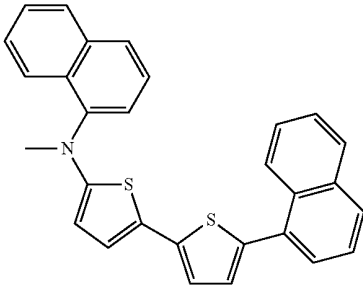
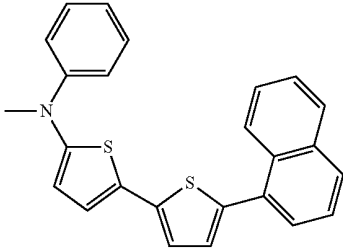
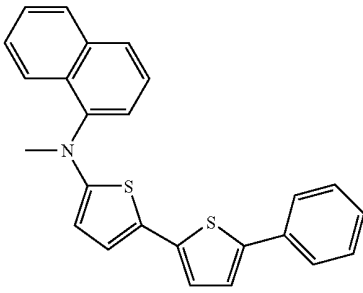

420

-continued

532

5

10

533

15

20

544

25

30

35

545

40

546

45

50

547

548

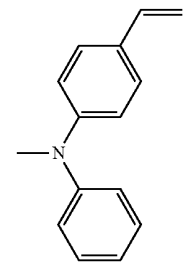
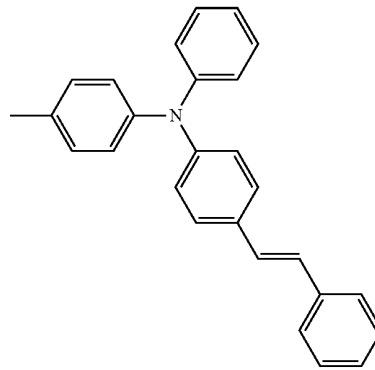

13. An organic light emitting diode comprising a first electrode, at least one organic material layer, and a second electrode, wherein the first electrode, the organic material layer(s), and the second electrode form a layered structure and at least one layer of the organic material layers comprises the compound of claim 1.

14. The organic light emitting diode according to claim 13, wherein the organic material layer comprises a hole transport layer, and the hole transport layer contains the compound.

15. The organic light emitting diode according to claim 13, wherein the organic material layer comprises a hole injection layer, and the hole injection layer contains the compound.

16. The organic light emitting diode according to claim 13, wherein the organic material layer comprises a hole injection and transport layer, and the hole injection and transport layer contains the compound.

\* \* \* \* \*

**41**  
-continued

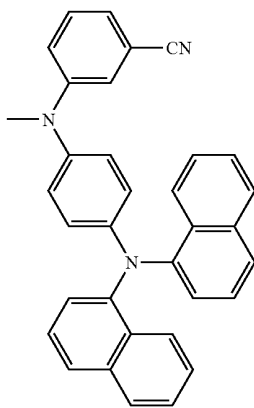
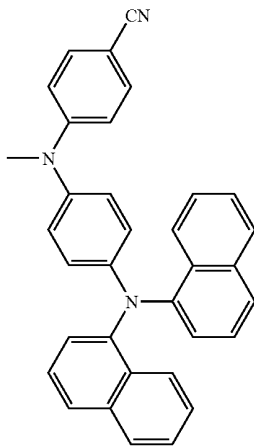
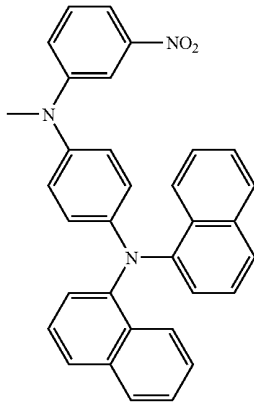

**42**  
-continued

100

5

103

10

15

20

25

101

30

35

40

45

102

50

55

60

65

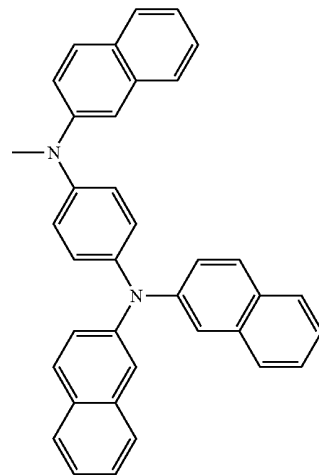
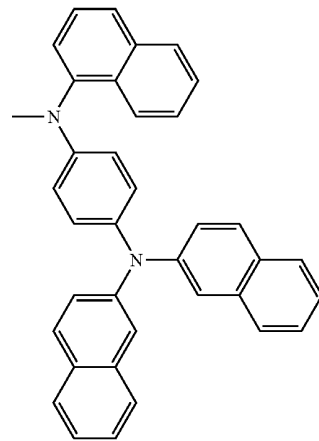
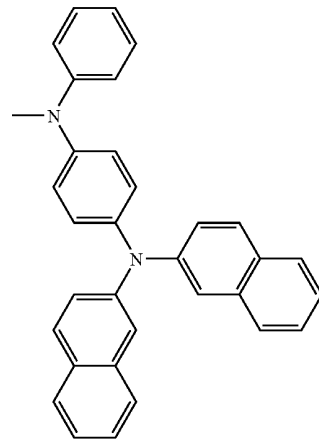

**43**  
-continued

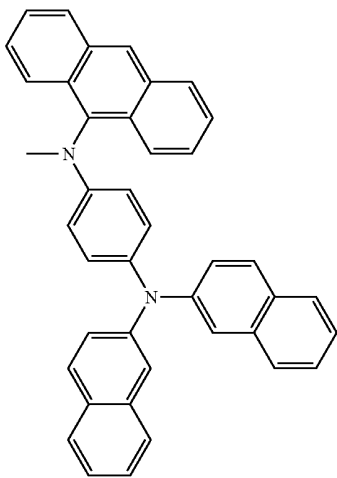
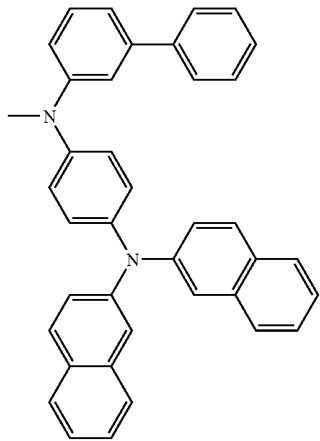
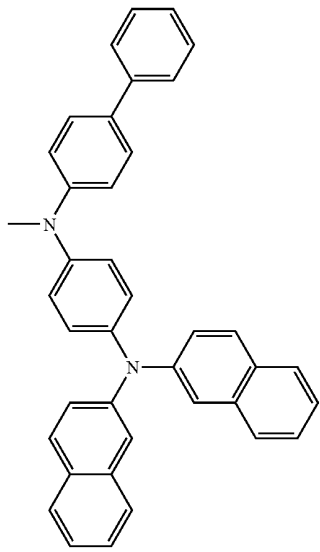

**44**  
-continued

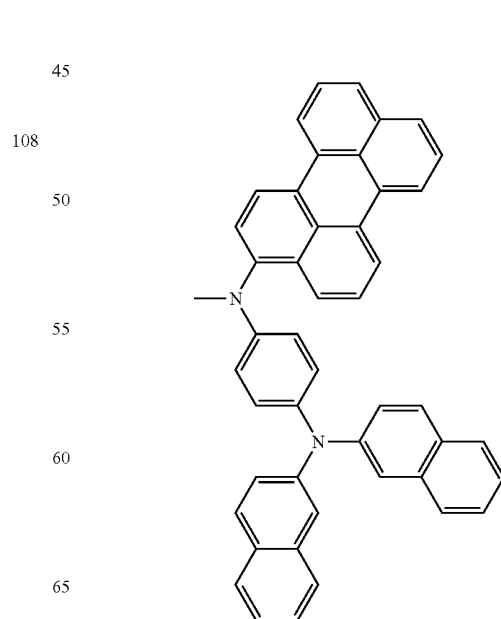
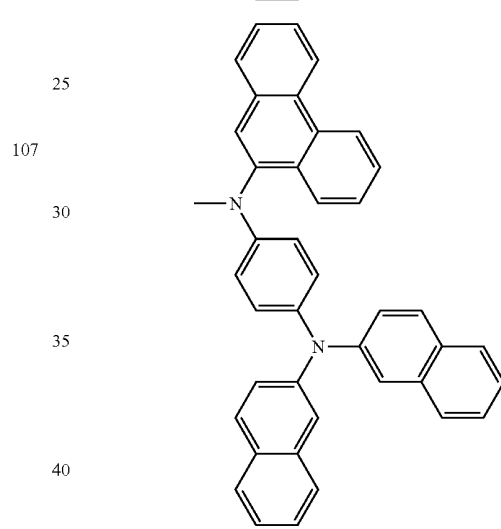
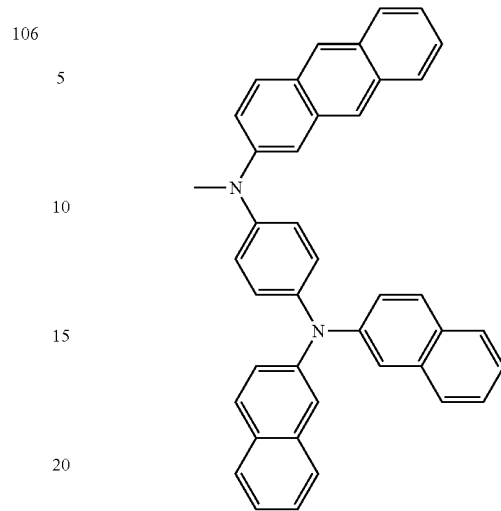

109

110

111

**45**  
-continued

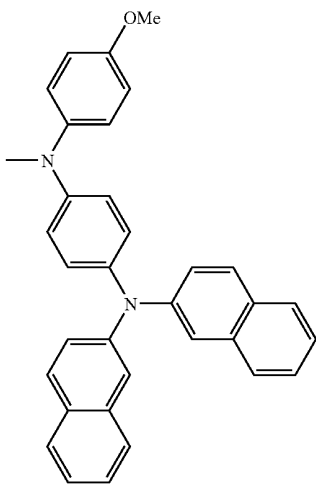
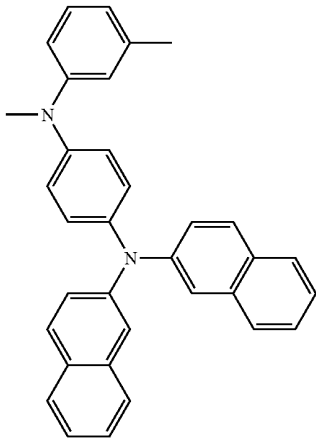
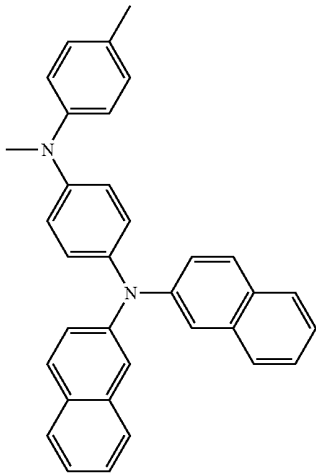

**46**  
-continued

112

5

10

15

20

25

113

30

35

40

45

114

50

55

60

65

115

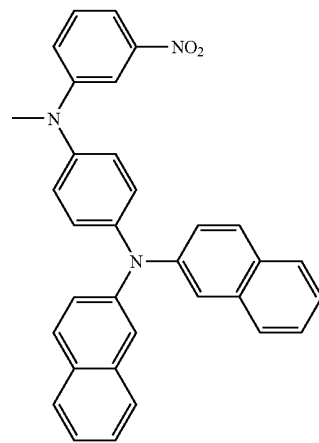
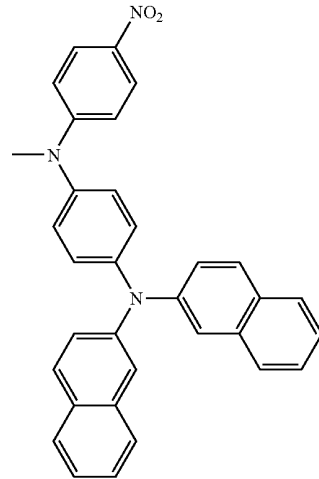
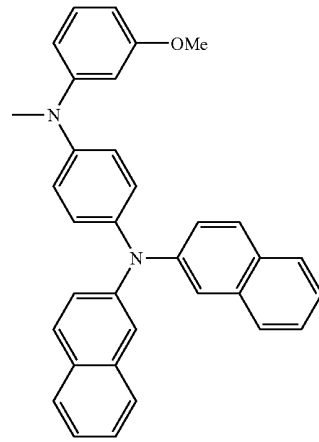

116

117

**47**  
-continued

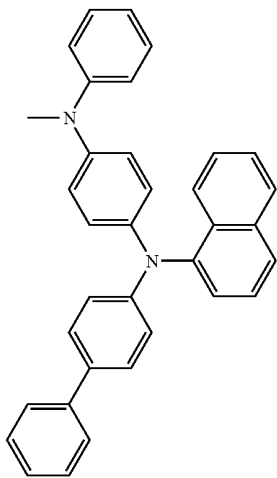
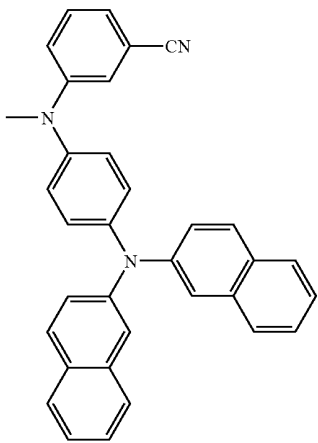
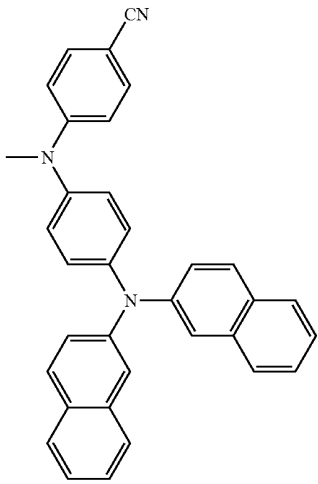

**48**  
-continued

118 5

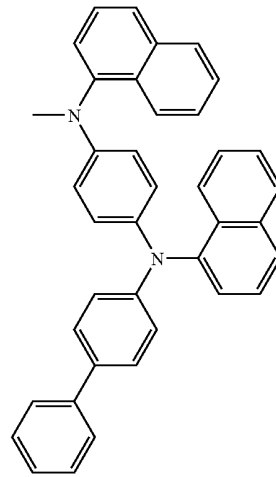

10

15

20

25

119

30

35

40

45

120

50

55

60

65

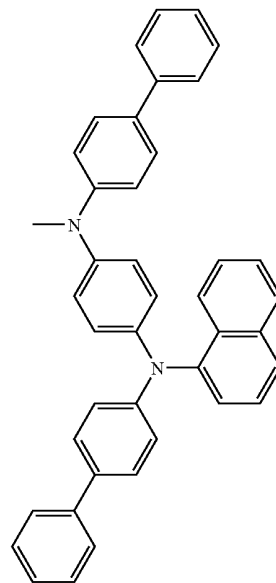
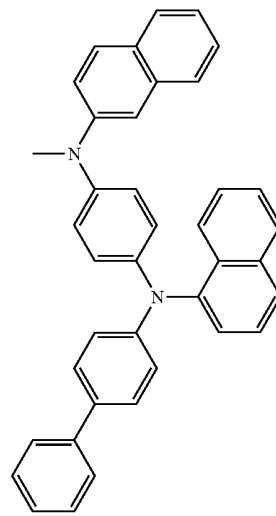

121

122

123

49

-continued

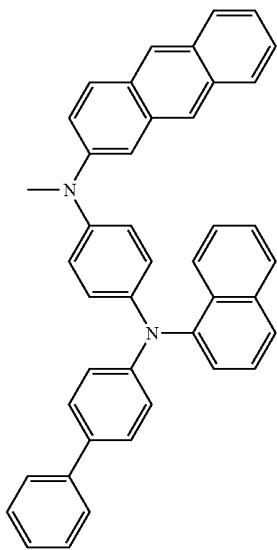
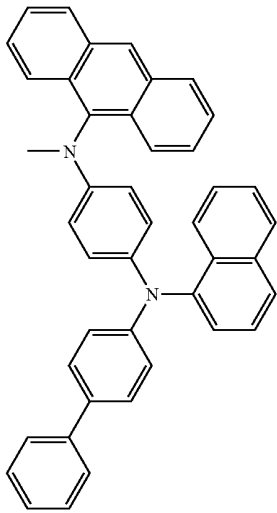
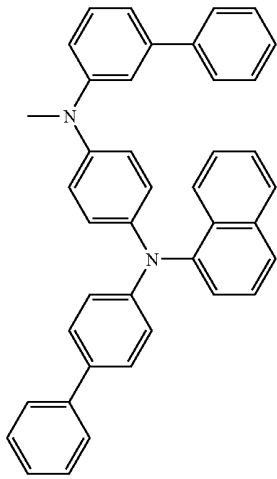

50

-continued

124

127

5

10

15

20

125

128

25

30

35

40

126 45

129

50

55

60

65

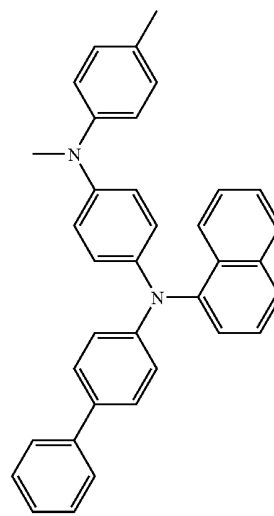
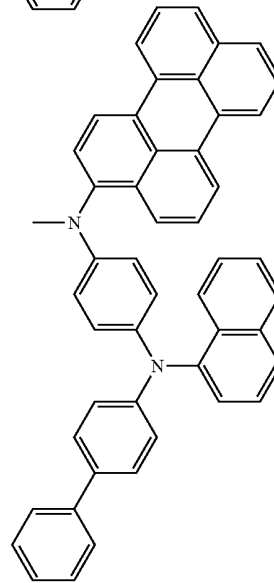
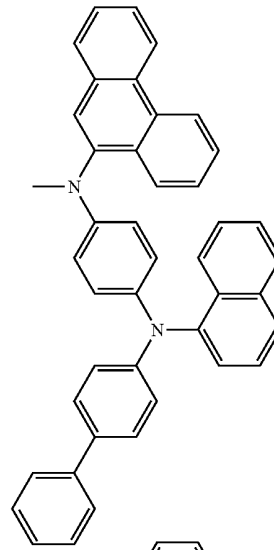

51

-continued

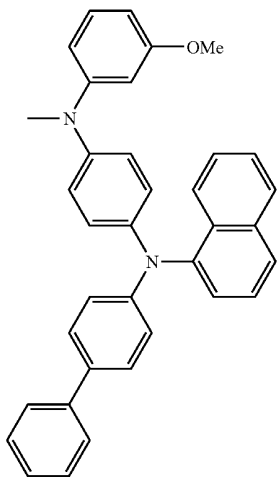
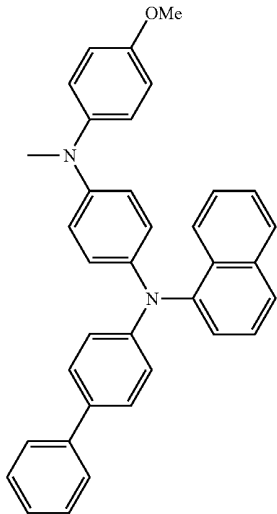
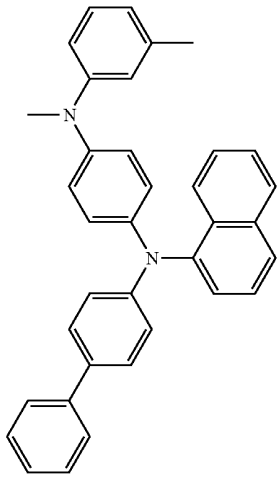

52

-continued

130  
5  
10  
15  
20

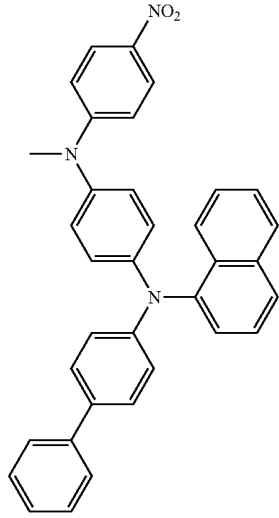

131  
25  
30  
35  
40  
45

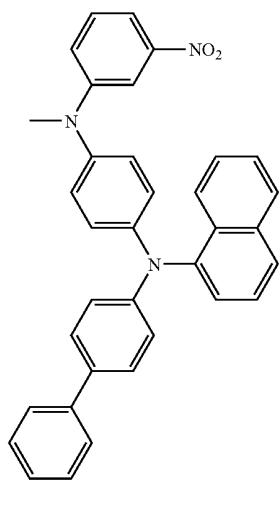

132  
50  
55  
60  
65

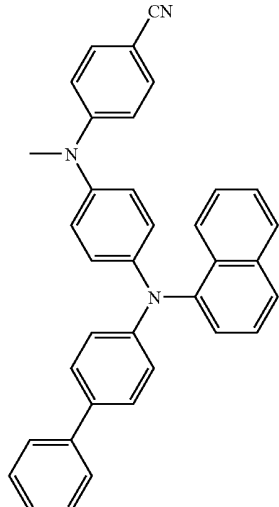

133

134

135

**53**  
-continued

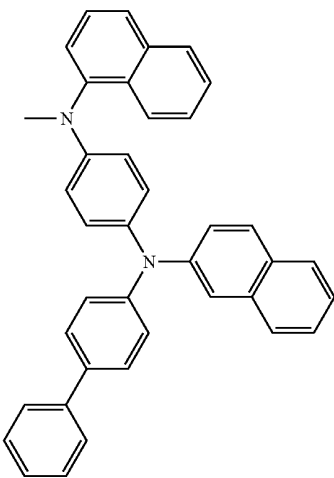
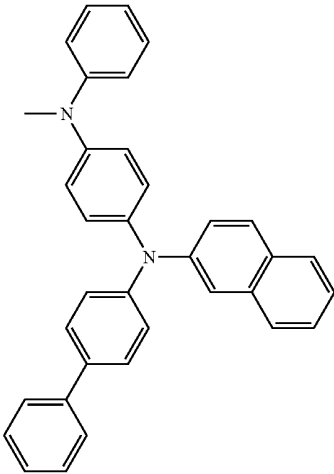
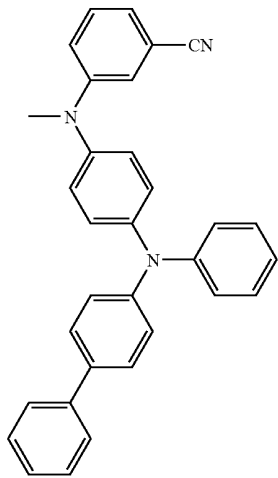

**54**  
-continued

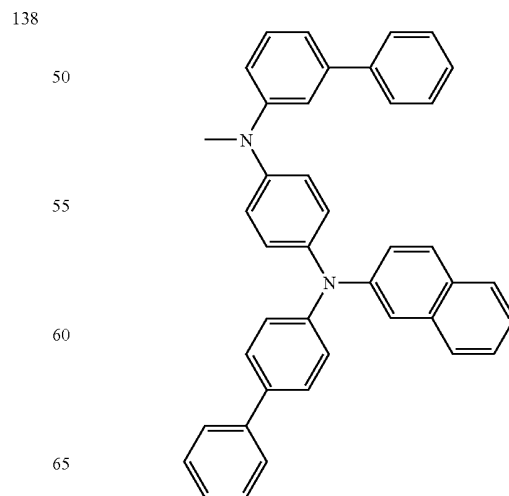
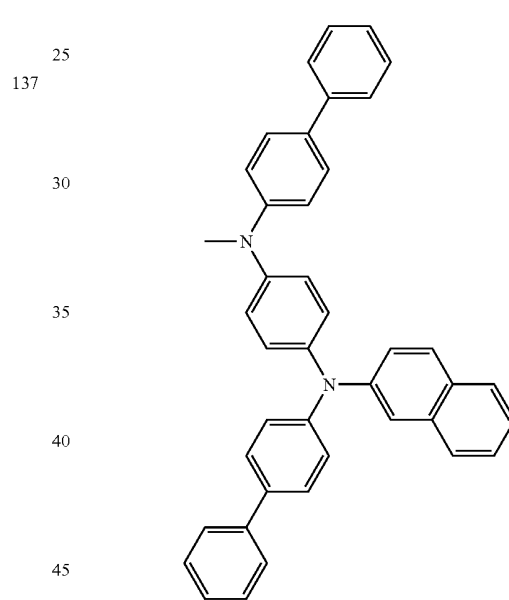
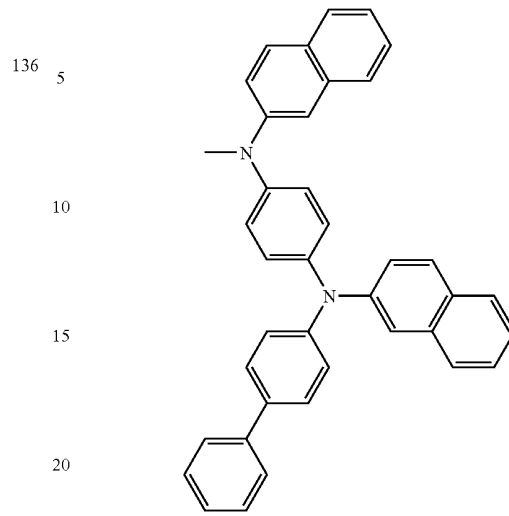

139

140

141

**55**  
-continued

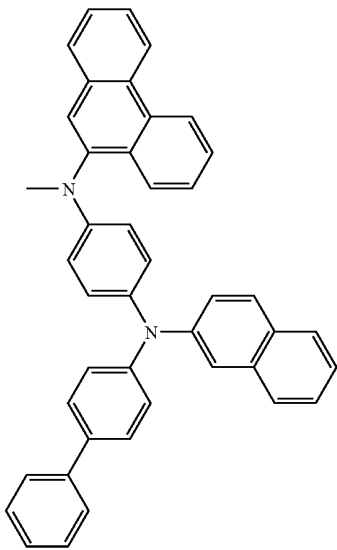
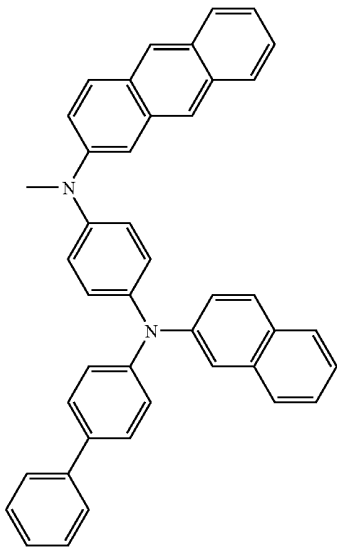
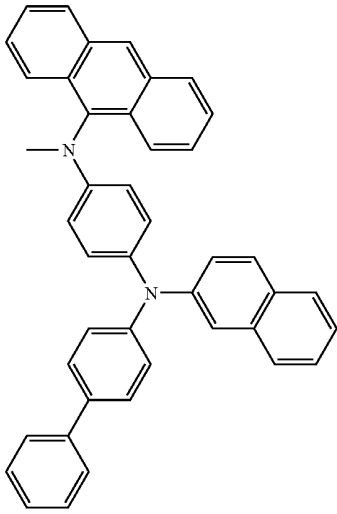

**56**  
-continued

142

5

10

15

20

143

25

30

35

40

144 45

50

55

60

65

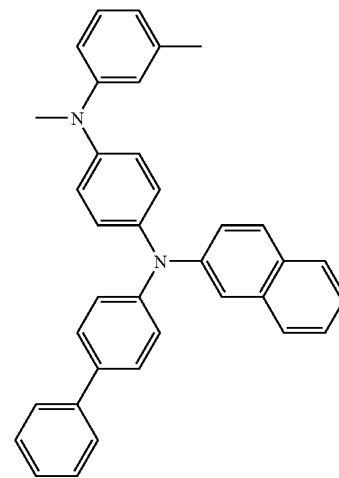
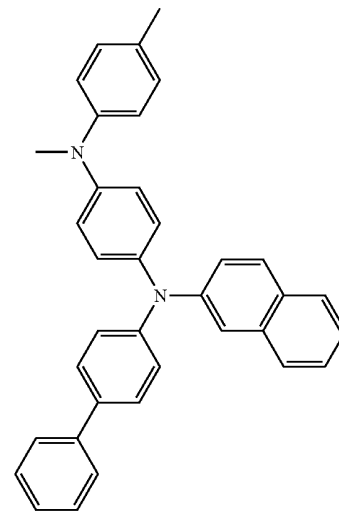
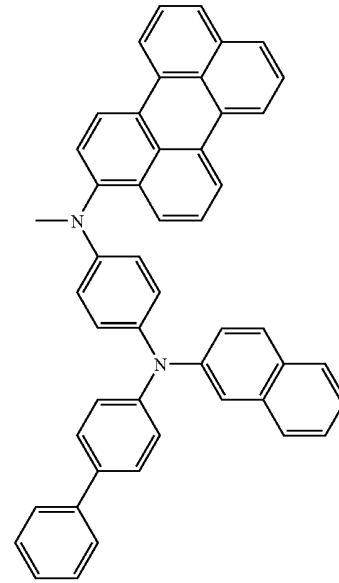

145

146

147

3

alkyl, alkoxy, and amino groups; a bivalent heterocyclic group; or a bivalent heterocyclic group which is substituted with at least one substituent group selected from the group consisting of nitro, nitrile, halogen, alkyl, alkoxy, and amino groups,

R1 to R11 may be the same or different from each other, and each independently hydrogen, a substituted or unsubstituted alkyl group, a substituted or unsubstituted alkoxy group, a substituted or unsubstituted alkenyl group, a substituted or unsubstituted aryl group, a substituted or unsubstituted arylamine group, a substituted or unsubstituted heterocyclic group, an amino group, a nitrile group, a nitro group, a halogen group, an amide group, or an ester group, in which they may form aliphatic, aromatic or hetero condensation rings along with adjacent groups,

R12 and R13 may be the same or different from each other, and each independently hydrogen, a substituted or unsubstituted alkyl group, a substituted or unsubstituted alkoxy group, a substituted or unsubstituted alkenyl group, a substituted or unsubstituted aryl group, a substituted or unsubstituted heterocyclic group, an amino group, a nitrile group, a nitro group, a halogen group, an amide group, or an ester group, in which they may form aliphatic, aromatic or hetero condensation rings along with adjacent groups,

R7 and R8 may be directly connected to each other, or may form a condensation ring along with a group selected from the group consisting of O, S, NR, PR, C=O, CRR' and SiRR' in which R and R' are the same or different from each other, each independently hydrogen, a substituted or unsubstituted alkyl group, a substituted or unsubstituted alkoxy group, a substituted or unsubstituted alkenyl group, a substituted or unsubstituted aryl group, a substituted or unsubstituted arylamine group, a substituted or unsubstituted heterocyclic group, a nitrile group, an amide group, or an ester group, and may form a condensation ring to form a spiro compound,

p and q may be each independently an integer of 1 to 5, with the proviso that when p is an integer of 2 or more, q is 1, and when q is an integer of 2 or more, p is 1,

A is

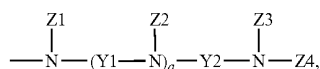

B is

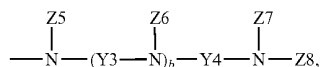

a and b may be each independently an integer of 0 to 10,

Y1 to Y4 may be the same or different from each other, and each independently bivalent aromatic hydrocarbons; bivalent aromatic hydrocarbons which are substituted with at least one substituent group selected from the group consisting of nitro, nitrile, halogen, alkyl, alkoxy, and amino groups; a bivalent heterocyclic group; or a bivalent heterocyclic group which is substituted with at least one substituent group selected from the group consisting of nitro, nitrile, halogen, alkyl, alkoxy and amino groups, and

Z1 to Z8 may be the same or different from each other, and each independently hydrogen; aliphatic hydrocarbons having 1 to 20 carbon atoms; aromatic hydrocarbons; aromatic hydrocarbons which are substituted with at least one substituent group selected from the group consisting of nitro, nitrile,

4

halogen, alkyl, alkoxy, amino, aromatic hydrocarbon, and heterocyclic groups; a silicon group substituted with aromatic hydrocarbons; a heterocyclic group; a heterocyclic group which is substituted with at least one substituent group selected from the group consisting of nitro, nitrile, halogen, alkyl, alkoxy, amino, aromatic hydrocarbon, and heterocyclic groups; a thiophene group which is substituted with aliphatic hydrocarbons having 1 to 20 carbon atoms or aromatic hydrocarbons having 6 to 20 carbon atoms; or a boron group which is substituted with aromatic hydrocarbons.

Further, the present invention provides an organic light emitting diode which comprises a first electrode, at least one organic material layer, and a second electrode, wherein the first electrode, the organic material layer(s), and the second electrode form a layered structure and at least one layer of the organic material layers includes a compound represented by Formula 1 of the present invention.

#### Advantageous Effects

The compound of the present invention can be used as an organic material layer material, particularly, hole injection and/or transport materials in an organic light emitting diode, and when applied to an organic light emitting diode it is possible to reduce the actuating voltage of the device, to improve the light efficiency thereof, and to improve the lifespan of the device through the thermal stability of the compound.

#### BRIEF DESCRIPTION OF THE DRAWINGS

FIG. 1 illustrates an example of an organic light emitting diode comprising a substrate 1, an anode 2, a light emitting layer 3, and a cathode 4; and

FIG. 2 illustrates an example of an organic light emitting diode comprising a substrate 1, an anode 2, a hole injection layer 5, a hole transport layer 6, a light emitting layer 7, an electron transport layer 8, and a cathode 4.

#### BEST MODE FOR CARRYING OUT THE INVENTION

Hereinafter, a detailed description will be given of the present invention.

Substituent groups of Formula 1 will be described in detail, below.

In Y and Y1 to Y4 of Formula 1, examples of the bivalent aromatic hydrocarbons include monocyclic aromatic rings such as phenylene, biphenylene and terphenylene, and multicyclic aromatic rings such as naphthylene, anthracenylene, pyrenylene and perylenylene, but are not limited thereto.

In Y and Y1 to Y4 of Formula 1, examples of the bivalent heterocyclic group include thiophenylene, furylene, pyrrolylene, imidazolylene, thiazolylene, oxazolylene, oxadiazolylene, thiadiazolylene, triazolylene, pyridylene, pyridazylene, pyrazinylene, quinolylene and isoquinolylene, but are not limited thereto.

In Z1 to Z8 of Formula 1, examples of the aromatic hydrocarbons include monocyclic aromatic rings such as phenyl, biphenyl and terphenyl, and multicyclic aromatic rings such as naphthyl, anthracenyl, pyrenyl and perylenyl, but are not limited thereto.

In Z1 to Z8 of Formula 1, examples of the heterocyclic group include thiophene, furan, pyrrole, imidazole, thiazole, oxazole, oxadiazole, thiadiazole, triazole, pyridyl, pyridazol, pyrazine, quinoline and isoquinoline, but are not limited thereto.

**57**  
-continued

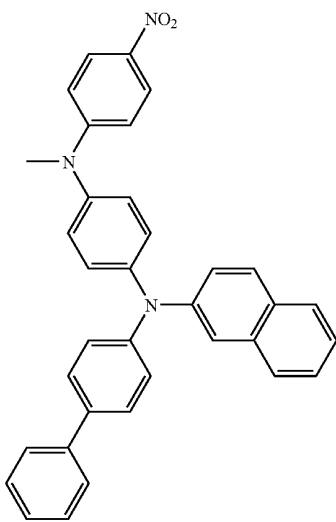
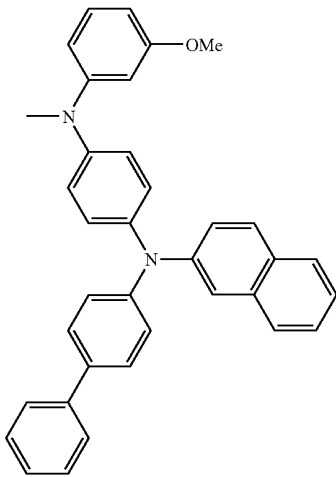
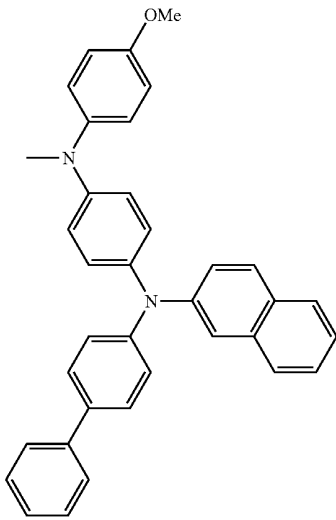

**58**  
-continued

148

5

10

15

20

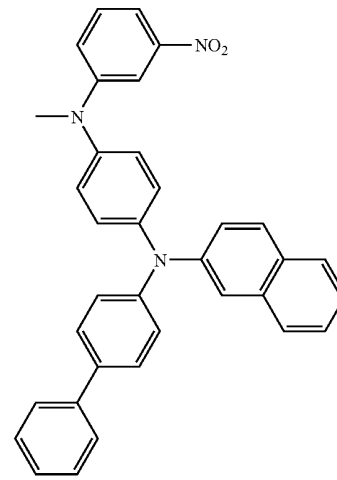

151

149

30

35

40

45

150

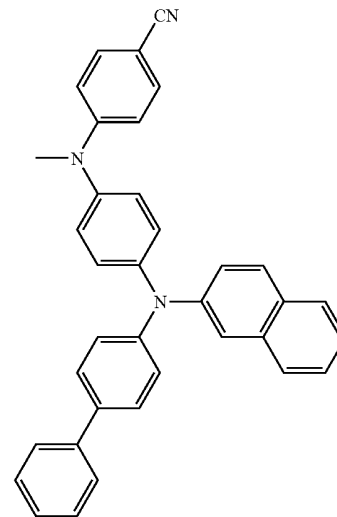

152

50

55

60

65

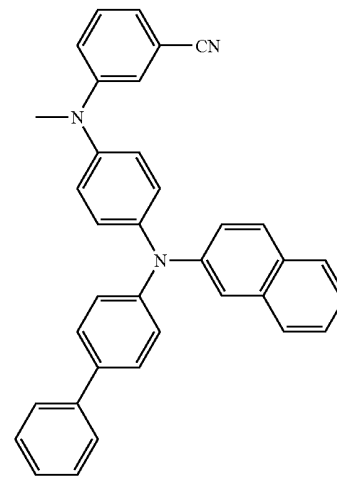

153

**59**  
-continued

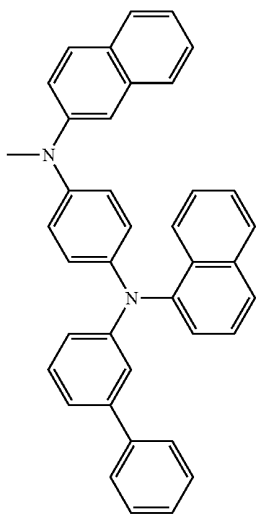
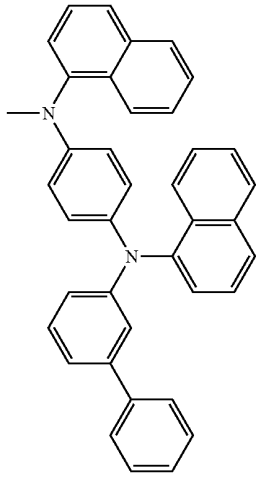
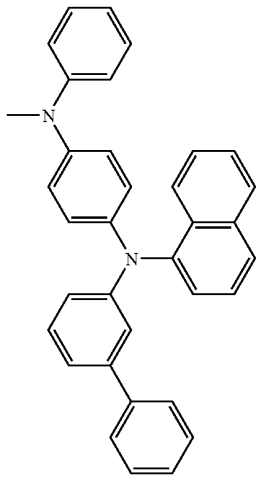

**60**  
-continued

154

5

10

15

20

155 25

30

35

40

156 45

50

55

60

65

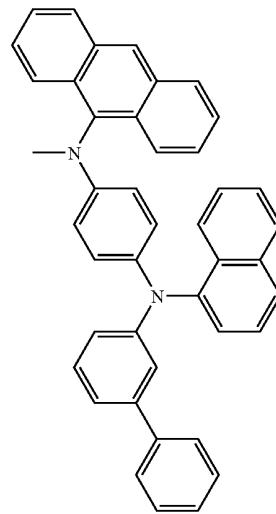
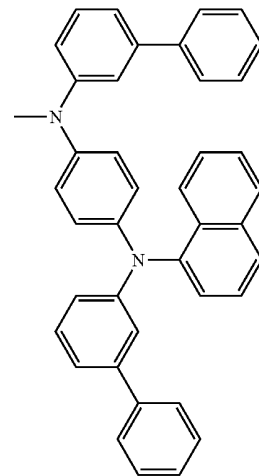
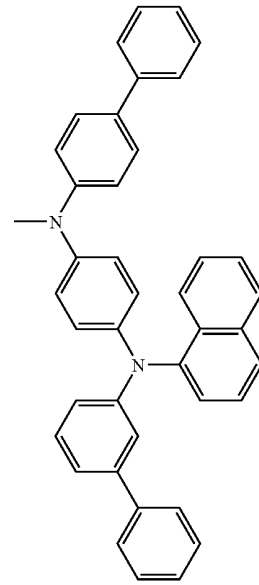

157

158

159

**61**  
-continued

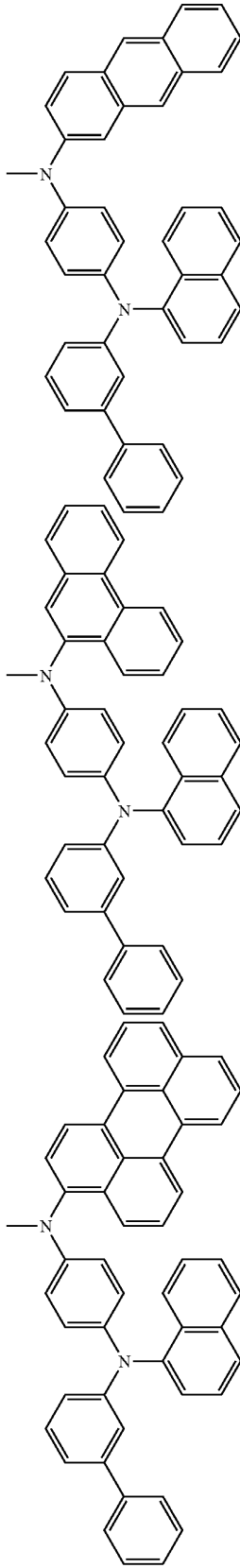

160

**62**  
-continued

5  
10  
15  
20  
161  
25  
30  
35  
40  
162  
45  
50  
55  
60  
65

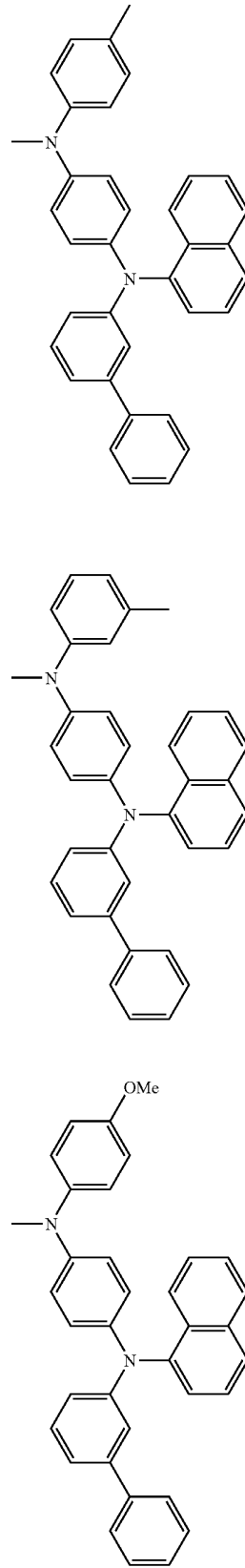

163

164

165

**63**  
-continued

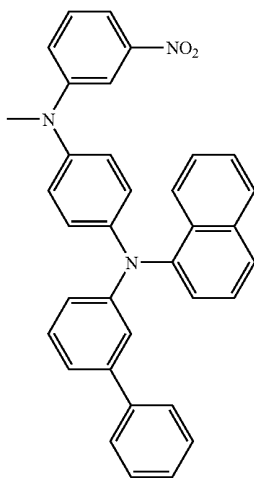
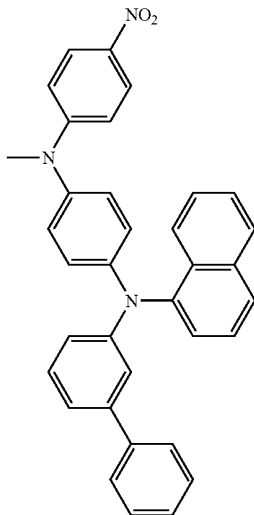
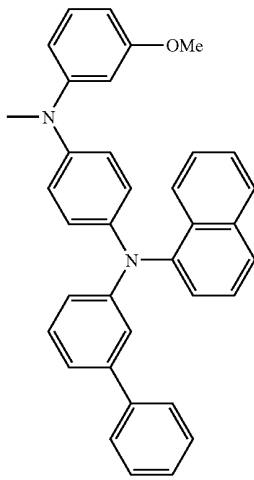

**64**  
-continued

166  
5  
10  
15  
20

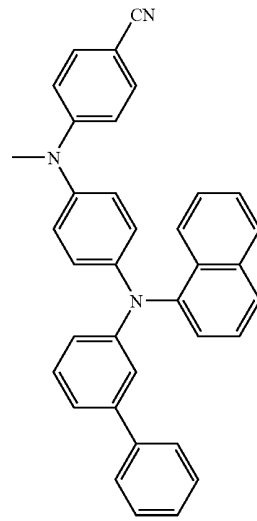

167 25  
30  
35  
40  
45

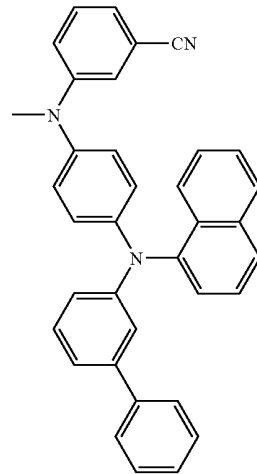

168  
50  
55  
60  
65

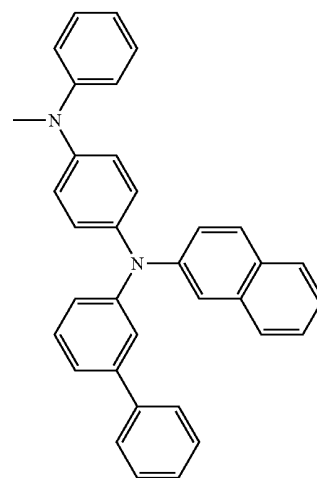

169

170

171

65

-continued

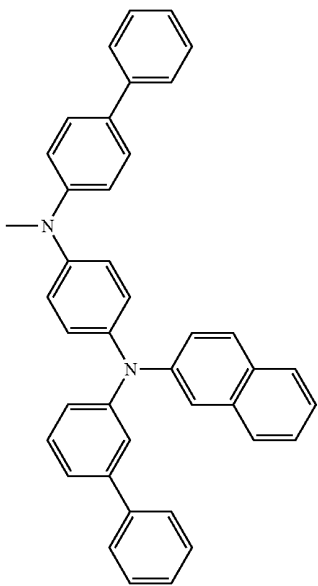
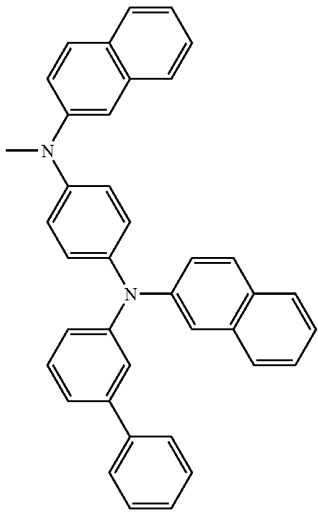
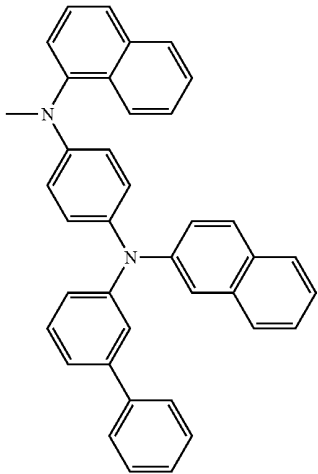

66

-continued

172

175

5

10

15

20

173

25

30

35

40

174

45

50

55

60

65

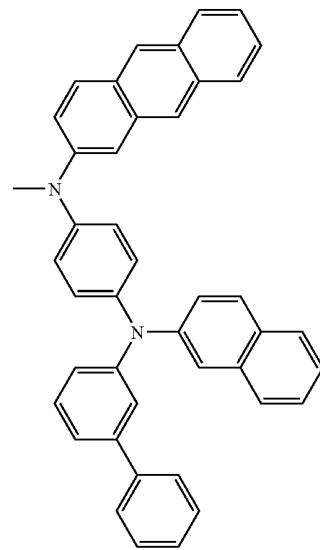
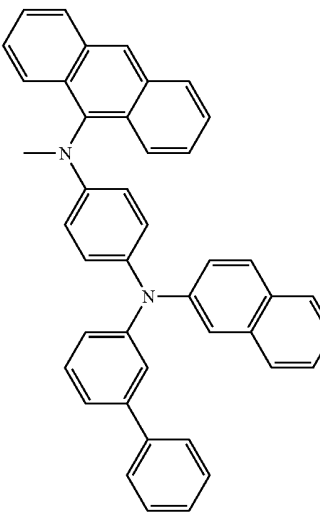
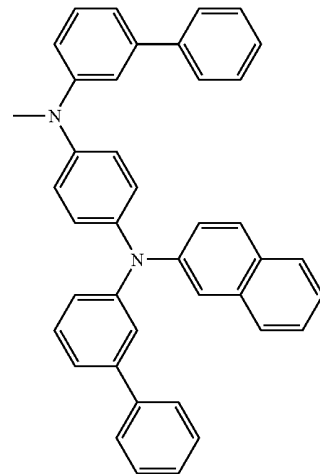

67

-continued

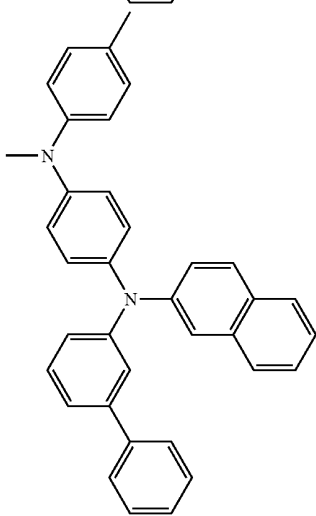
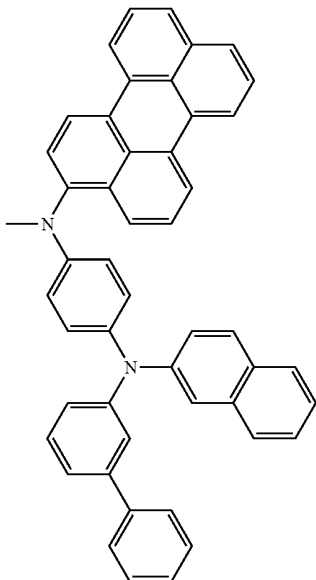
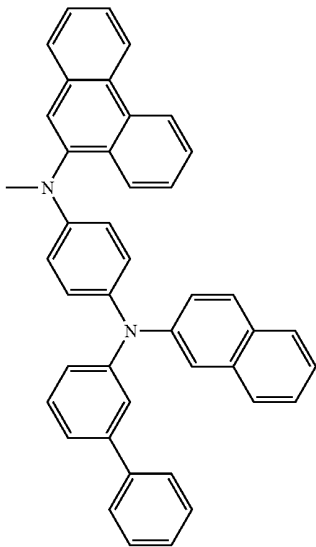

68

-continued

178

181

5

10

15

20

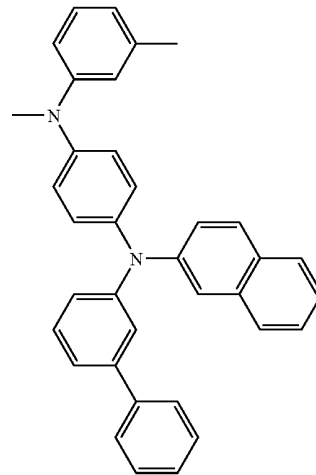

179

182

25

30

35

40

45

180

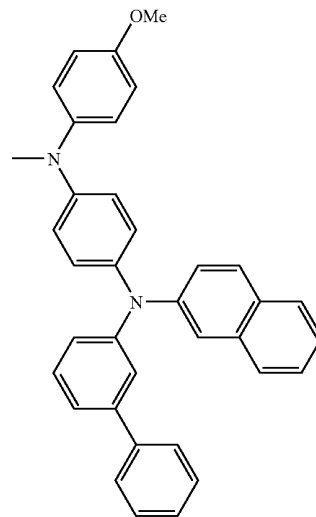

50

183

55

60

65

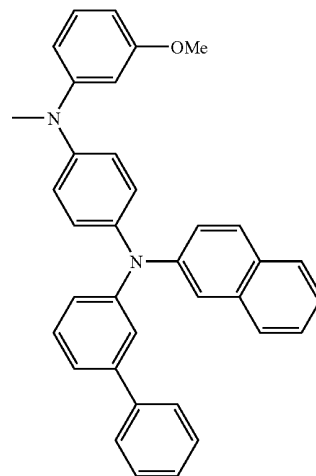

69

-continued

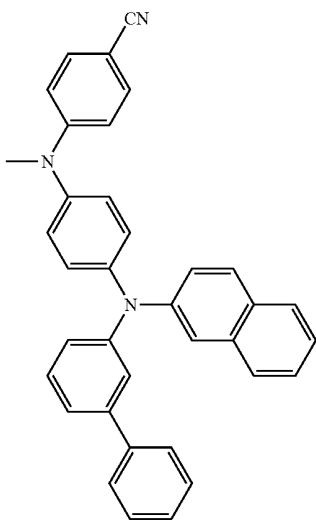
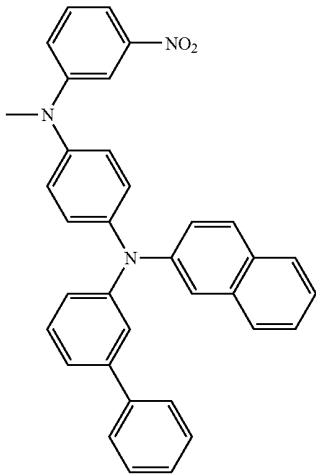
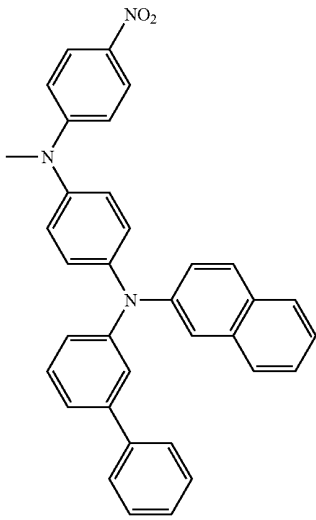

70

-continued

184

187

5

10

15

20

185

188

25

30

35

40

45

186

189

50

55

60

65

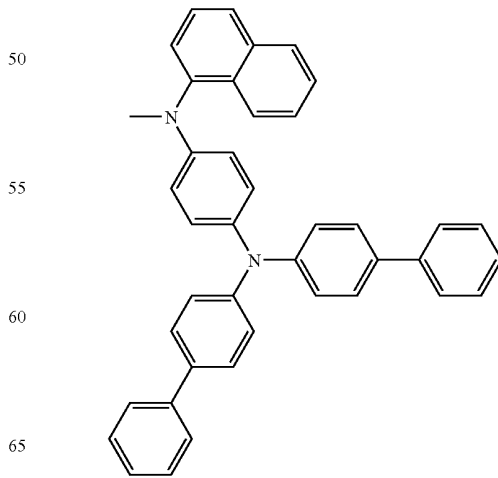
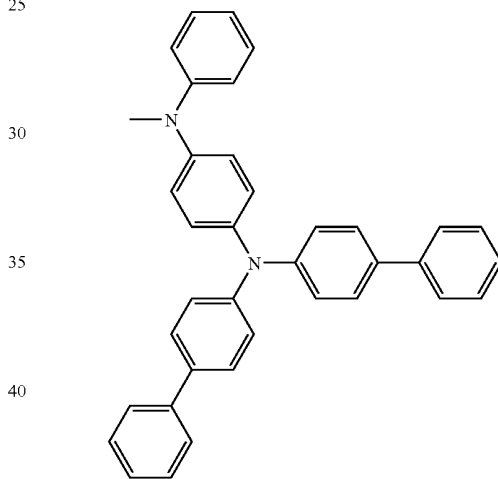
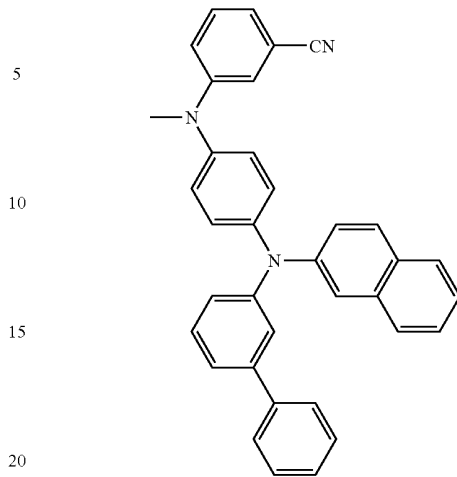

**71**  
-continued

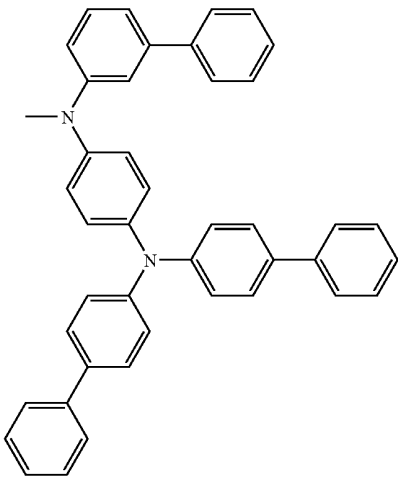
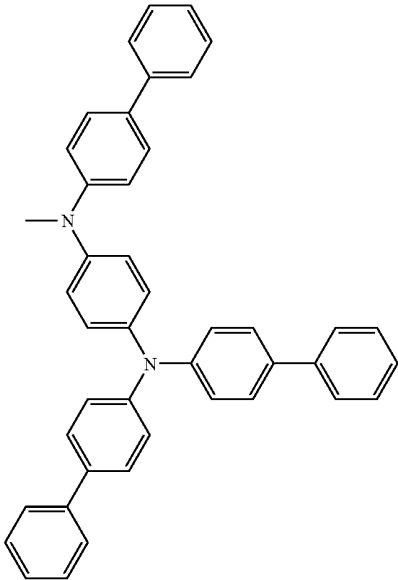
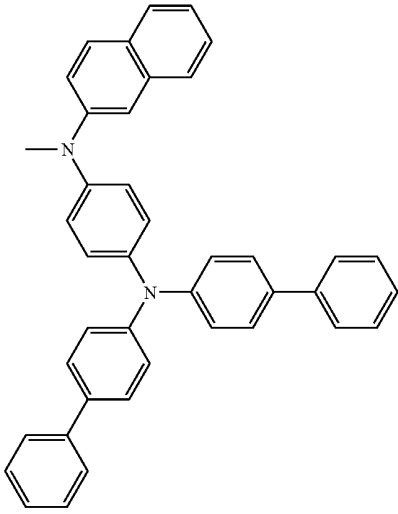

**72**  
-continued

190

193

5

10

15

20

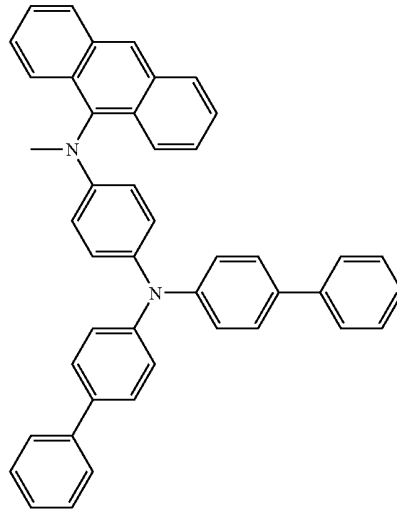

191

194

25

30

35

40

45

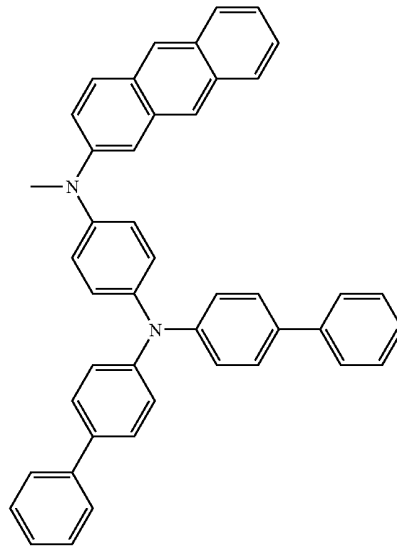

192

195

50

55

60

65

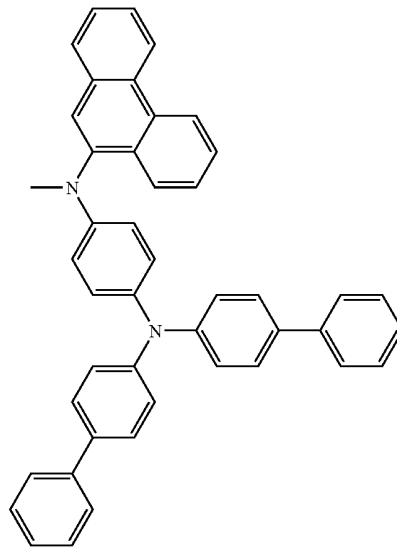

**73**  
-continued

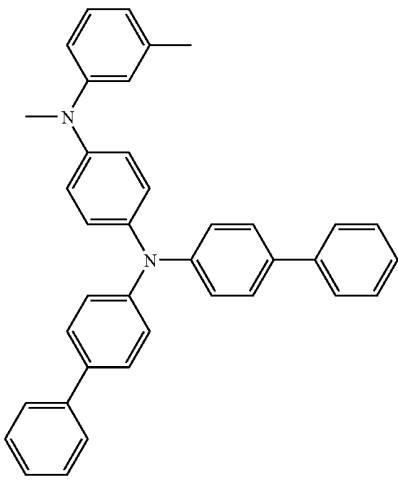
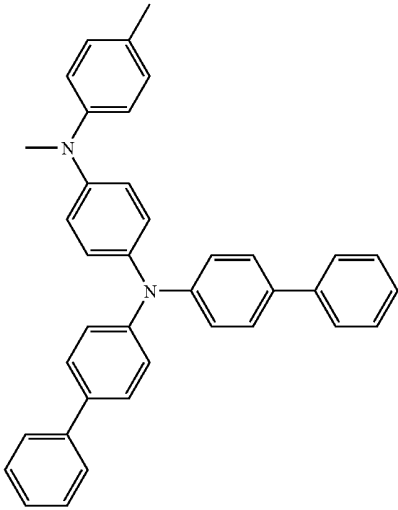
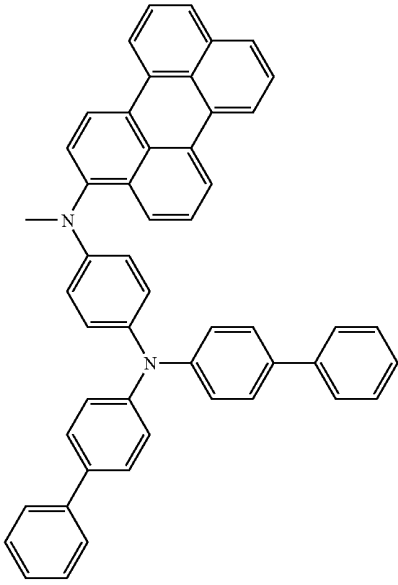

**74**  
-continued

196

199

5

10

15

20

25

197

200

30

35

40

45

198

201

50

55

60

65

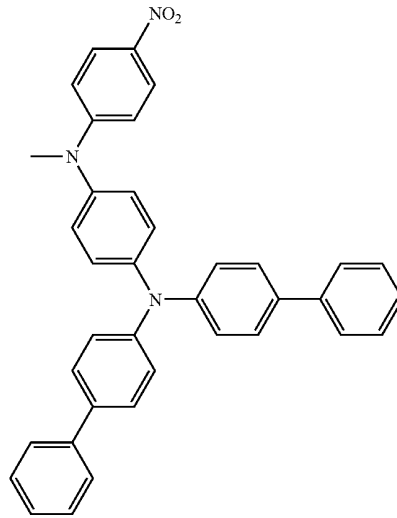
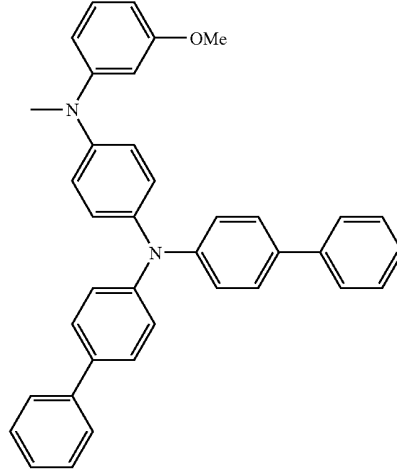
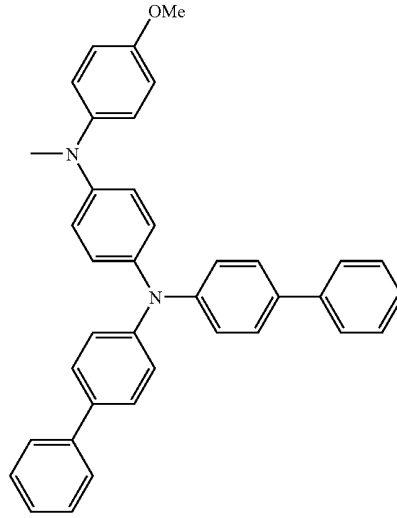

**75**  
-continued

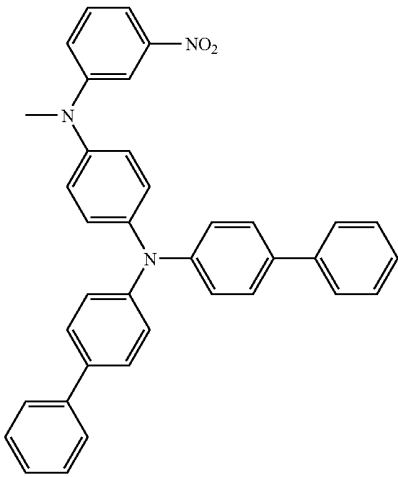

202

**76**  
-continued

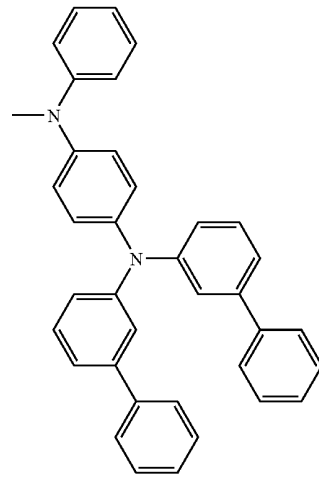

205

5

10

15

20

203

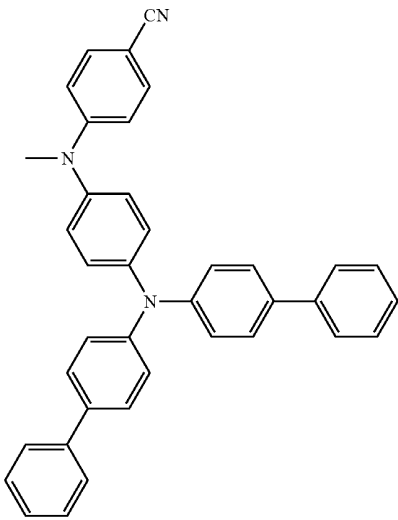

206

25

30

35

40

45

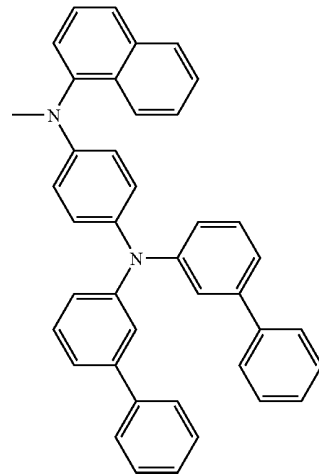

204

207

50

55

60

65

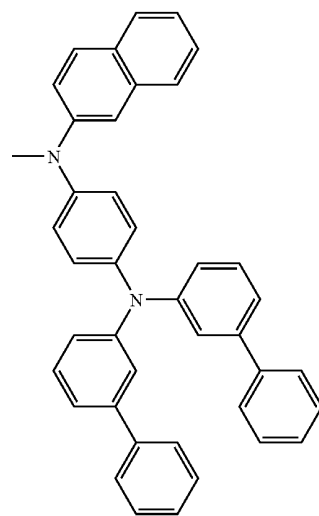
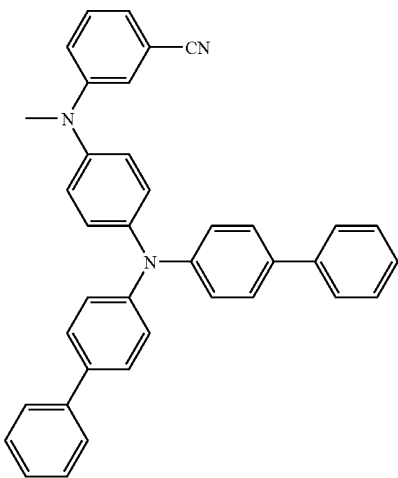



77  
-continued

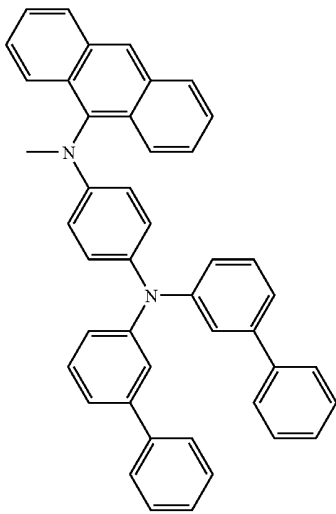
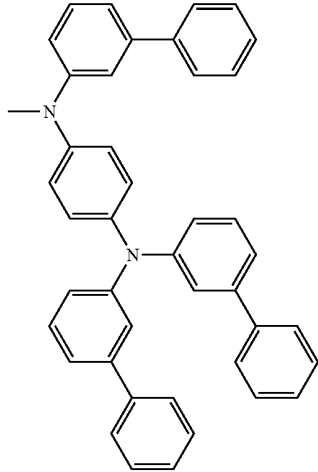
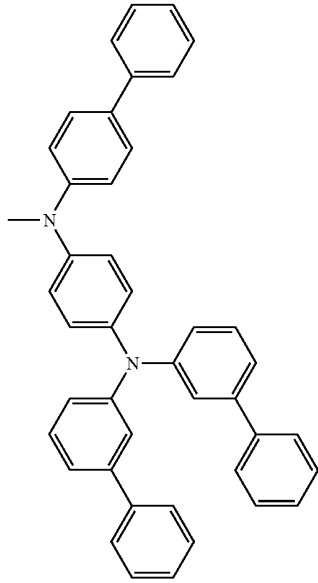

78  
-continued

208

211

5

10

15

20

209

25

30

35

40

210

45

50

55

60

65

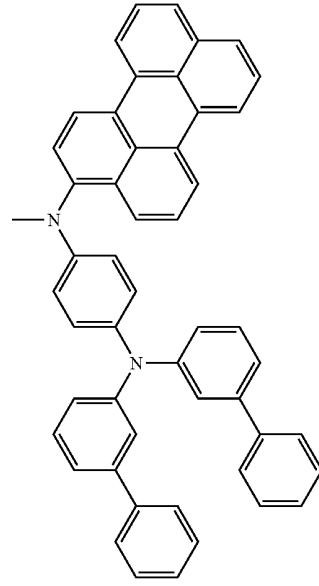
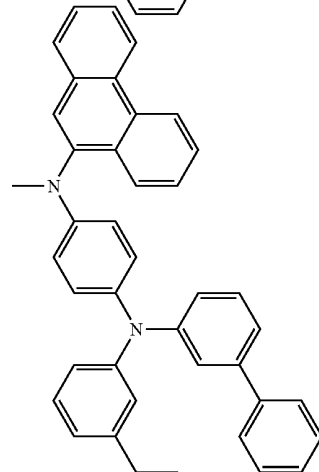
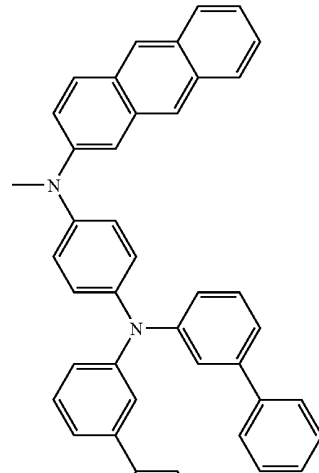

212

213

79

-continued

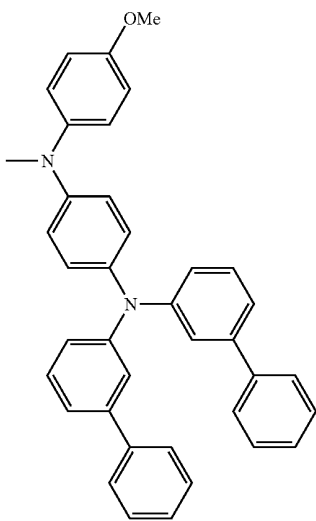
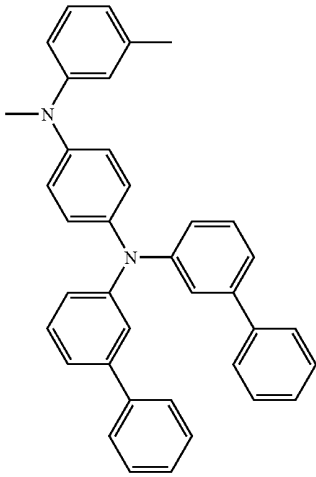
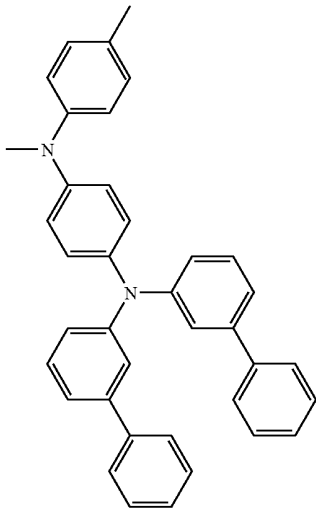

80

-continued

214

5

10

15

20

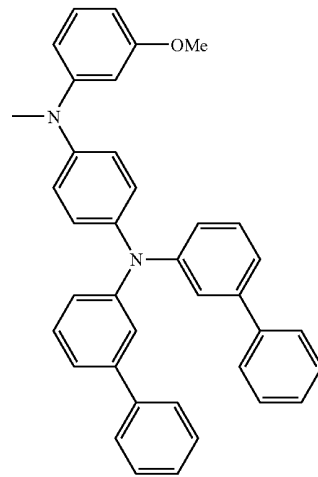

217

215

25

30

35

40

45

216

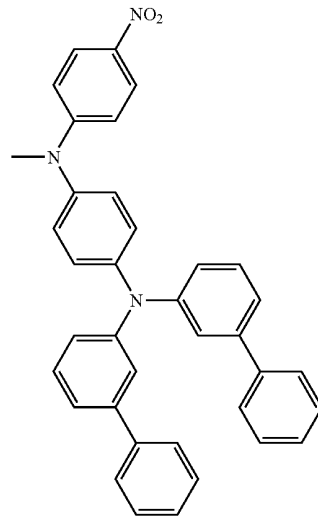

218

50

55

60

65

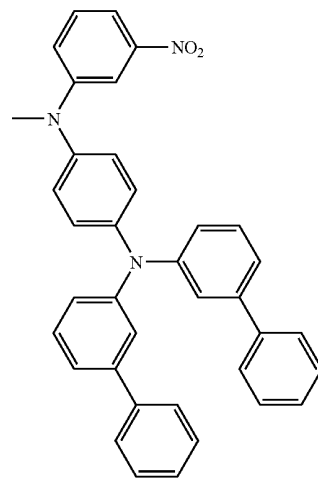

219

**81**  
-continued

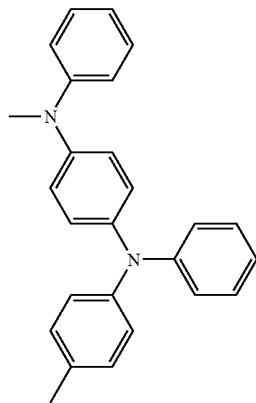
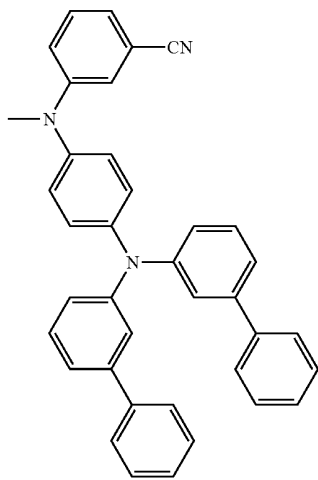
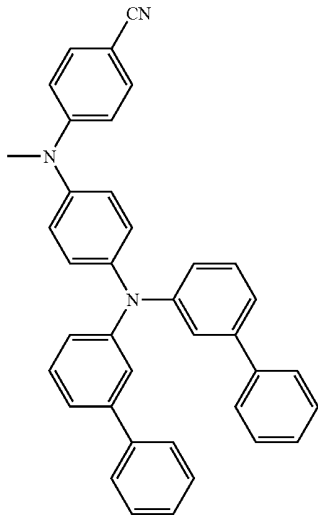

**82**  
-continued

220 5

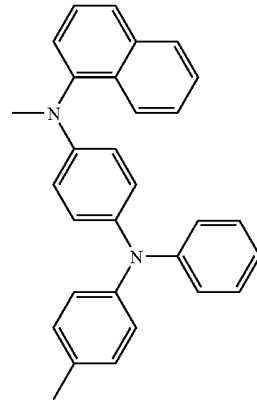

223

25

221

30

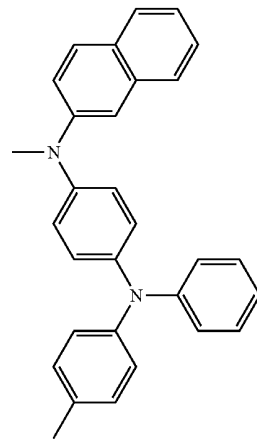

224

45

222 50

55

60

65

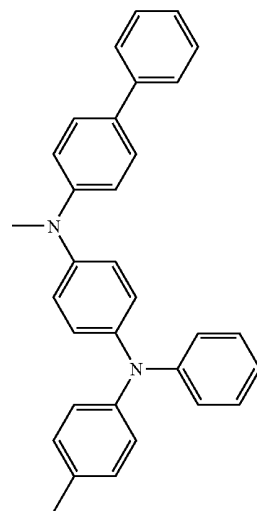

225

83

-continued

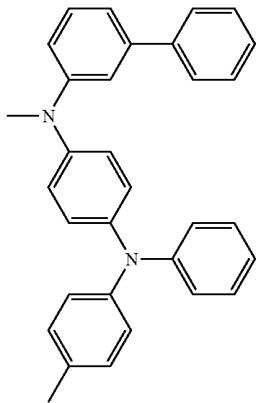

226

5

10

15

20

84

-continued

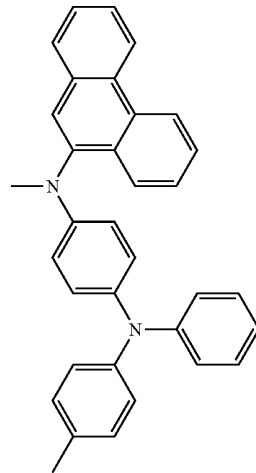

229

227 25

30

35

40

45

230

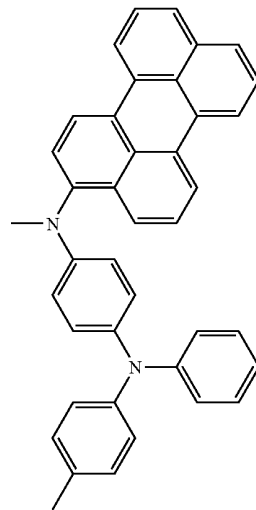
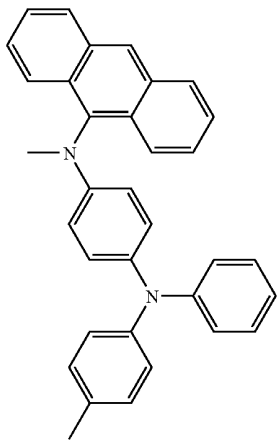

228

50

55

60

65

231

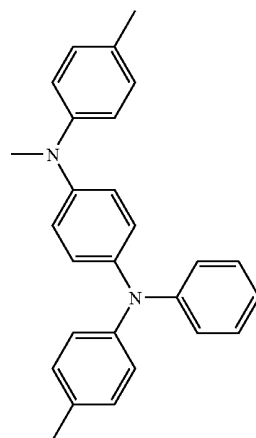
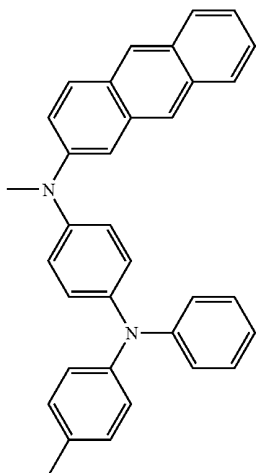

85

-continued

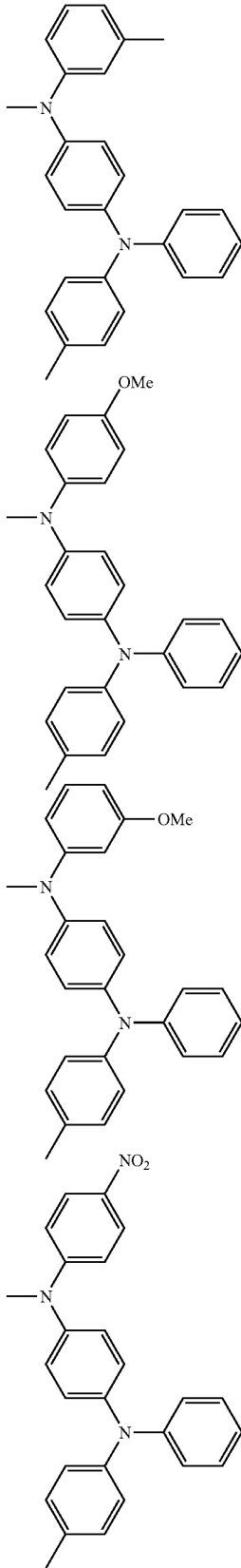

86

-continued

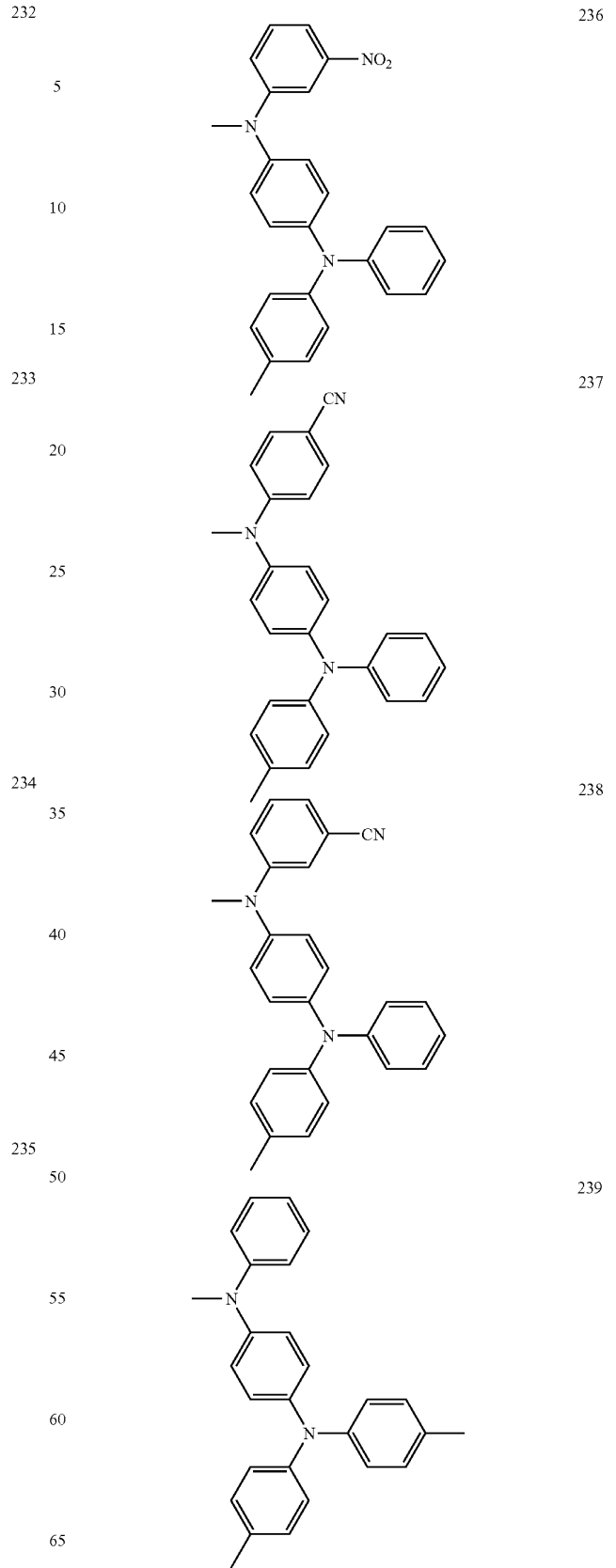

**87**  
-continued

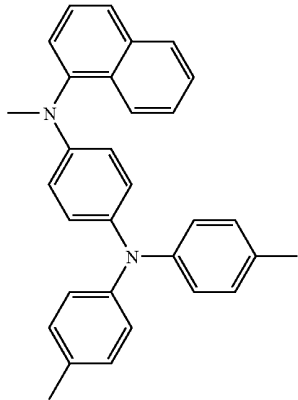

240 5  
10  
15  
20

**88**  
-continued

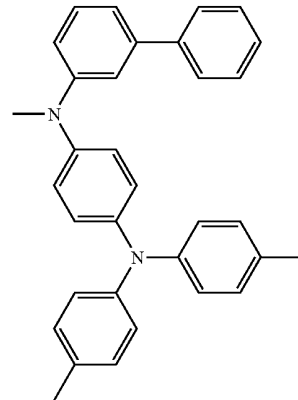

243

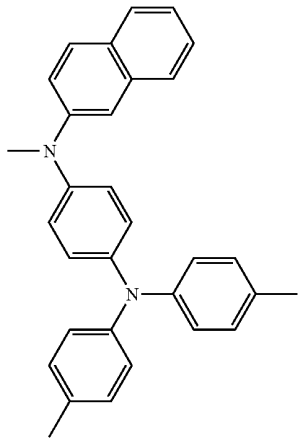

241 25  
30  
35  
40  
45  
242

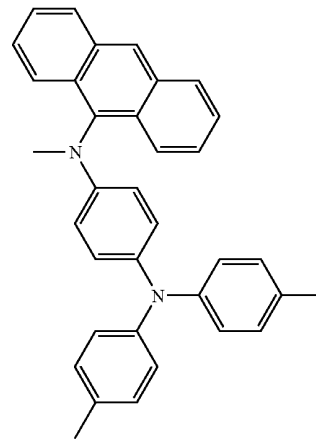

244

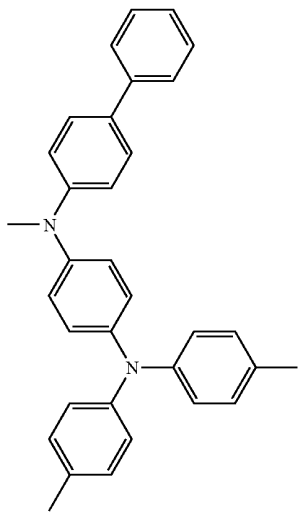

50  
55  
60  
65

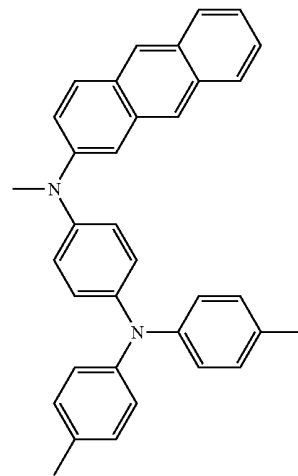

245

89

-continued

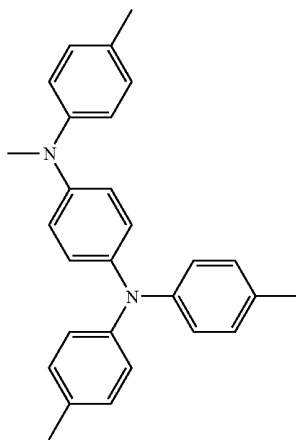
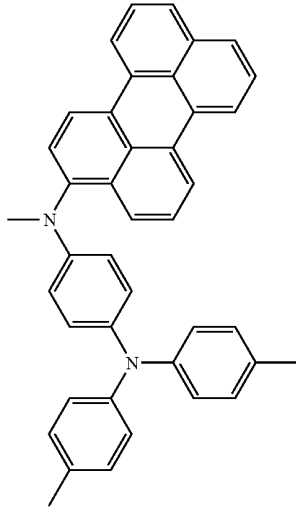
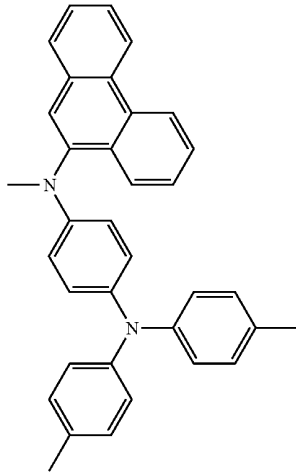

90

-continued

246 5

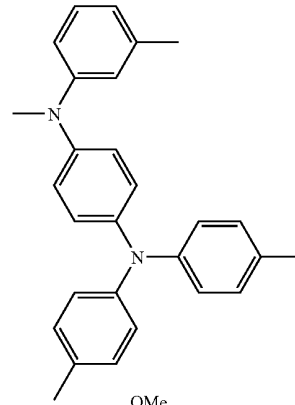

10

15

20

247 25

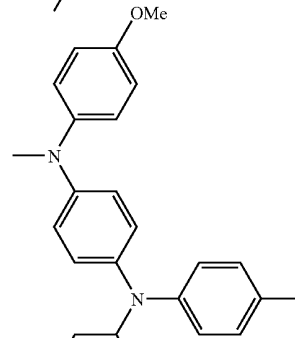

30

35

40

45

248 50

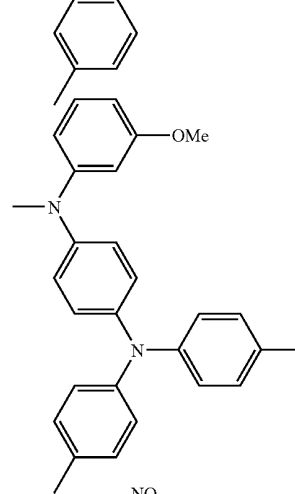

55

60

65

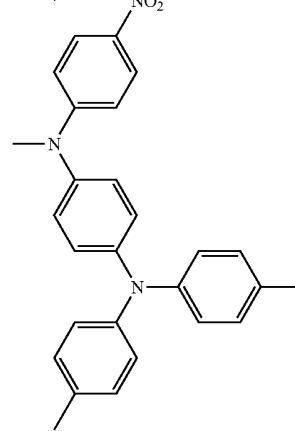

249

250

251

252

**91**  
-continued

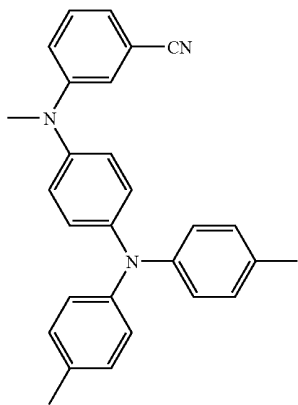
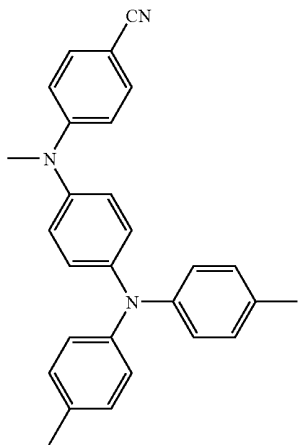
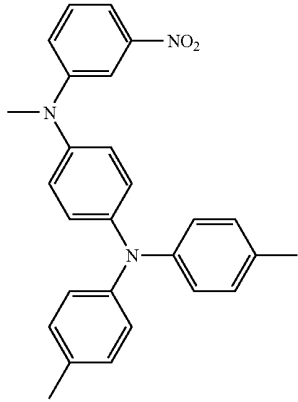

**92**  
-continued

5  
253

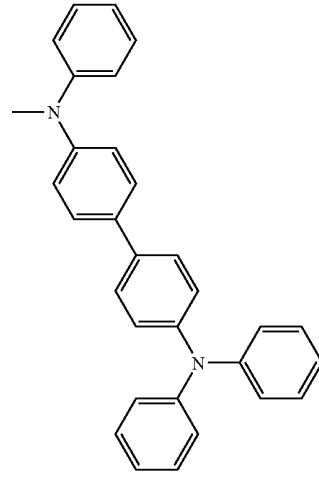

256

25  
254

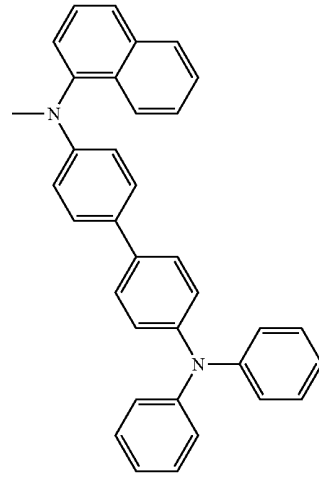

257

45  
255

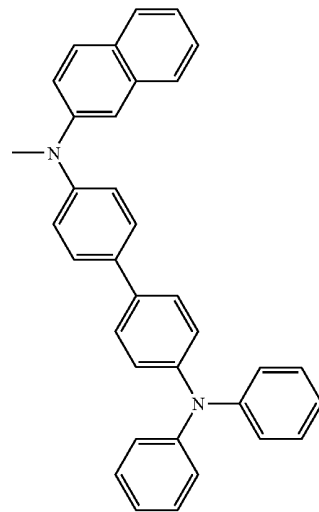

258

50

55

60

65

93

-continued

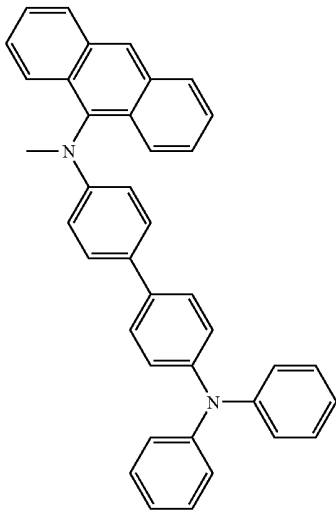
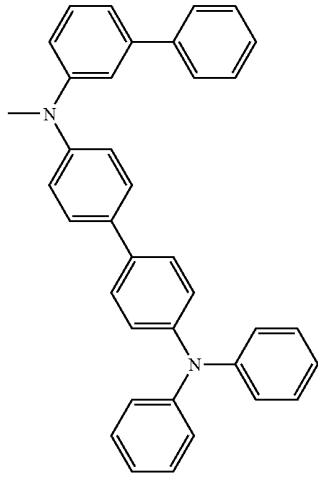
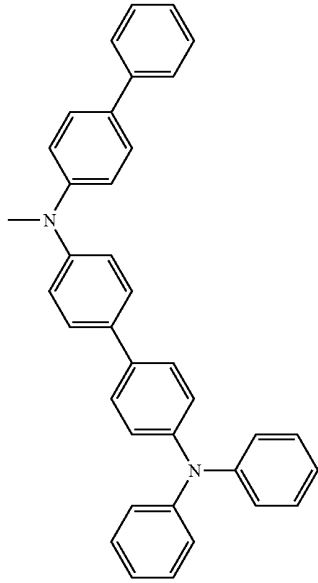

94

-continued

259

262

5

10

15

20

25  
260

30

35

40

45  
261

50

55

60

65

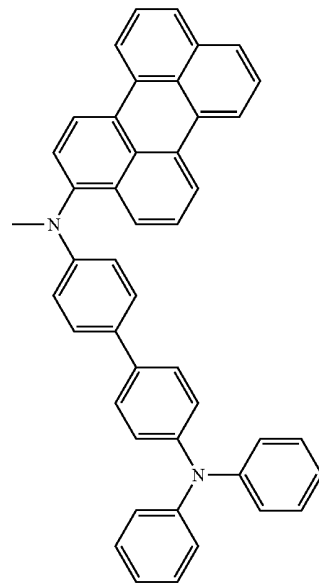
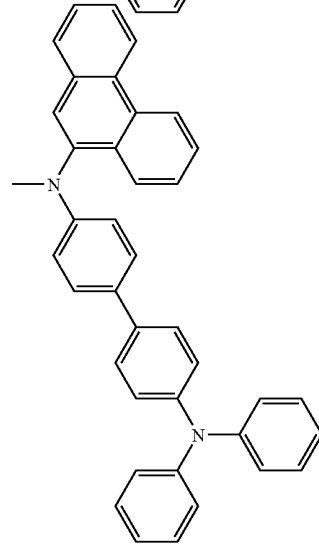
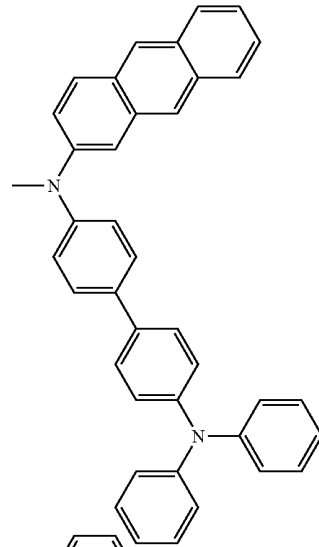

**95**  
-continued

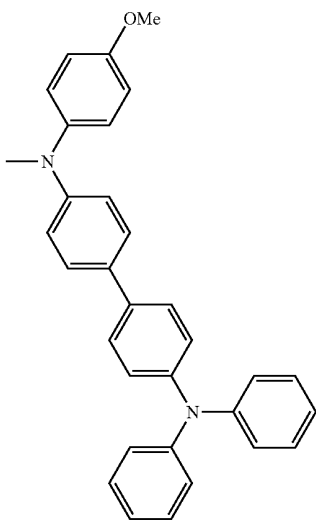
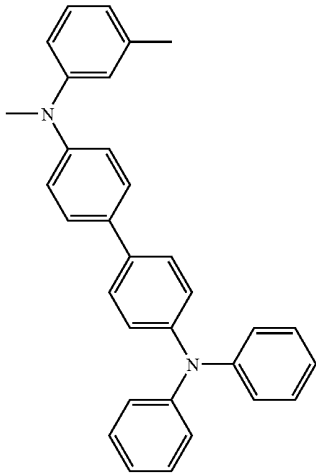
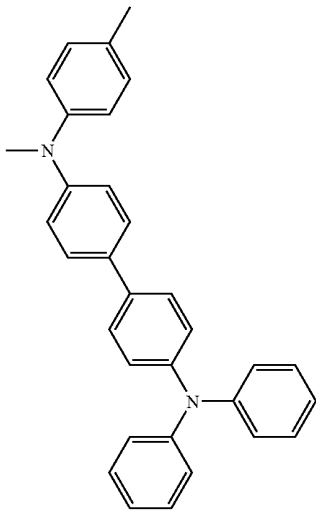

**96**  
-continued

265

5

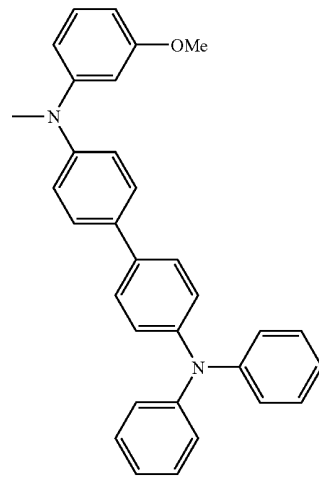

10

15

20

268

266

25

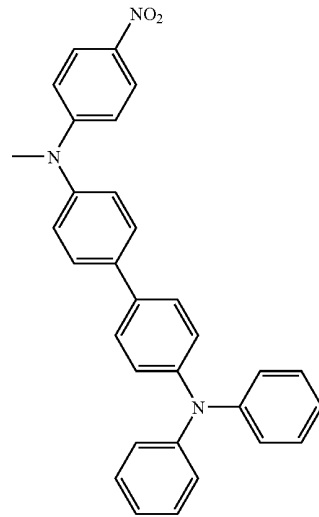

30

35

40

45

269

267

50

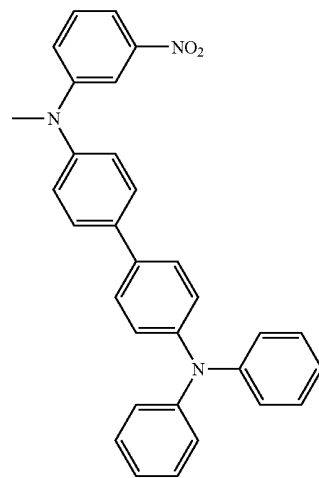

55

60

65

270

7

carbon atoms, an alkoxy group, an arylamine group, an aryl group, a heterocyclic group, a nitrile group, and an acetylene group. Specific examples of the arylamine, aryl, and heterocyclic groups of Z are as shown in the above-mentioned substituent groups of R1 to R13.

According to a preferred embodiment of the present invention, in Formula 1, X is C, R7 and R8 may be directly connected to each other, or form a condensation ring along with a group selected from the group consisting of O, S, NR, PR, C=O, CRR' and SiRR' (R and R' are as defined in Formula 1).

According to another preferred embodiment of the present invention, in Formula 1, X is Si, R7 and R8 may be directly connected to each other, or form a condensation ring along with a group selected from the group consisting of O, S, NR, PR, C=O, CRR' and SiRR' (R and R' are as defined in Formula 1).

According to still another preferred embodiment of the present invention, the compound of Formula 1 can be represented by any one of the following Formulae 2 to 7.

8

-continued

[Formula 4]

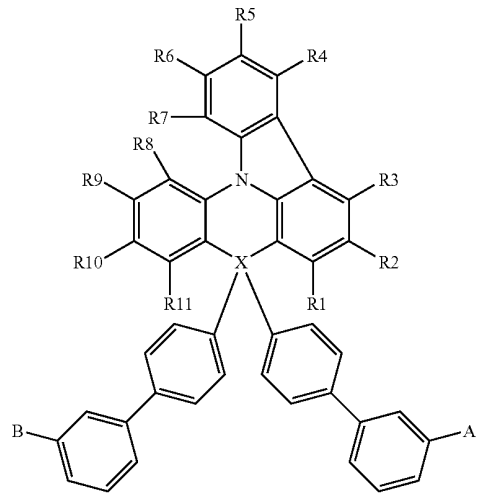

[Formula 5]

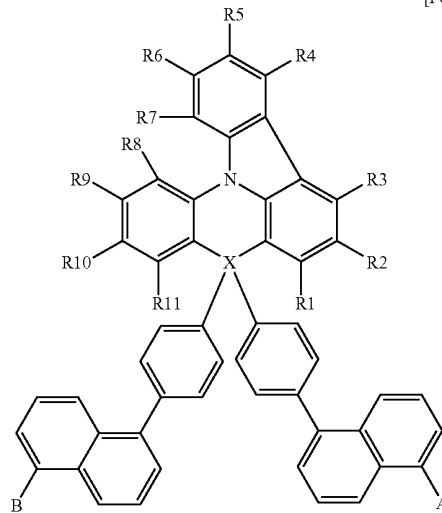

[Formula 6]

[Formula 2]

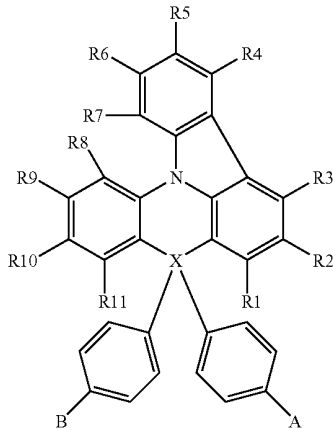

[Formula 3]

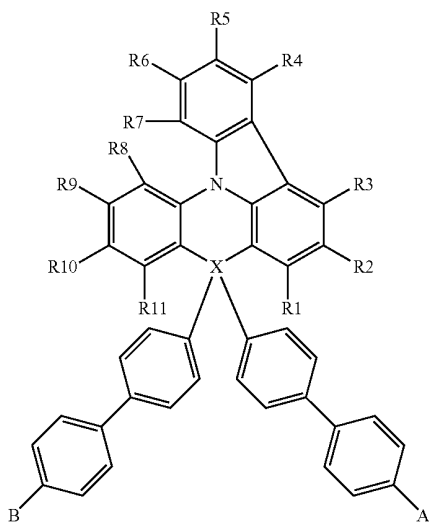

5

10

15

20

25

30

35

40

45

50

55

60

65

97

-continued

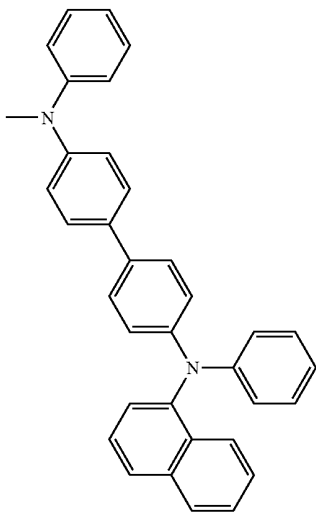
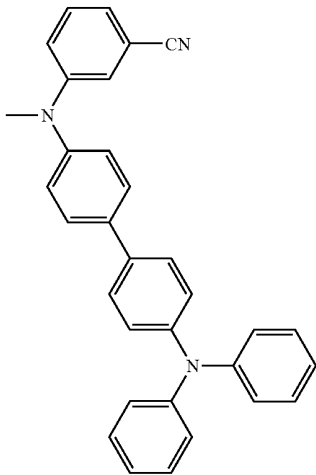
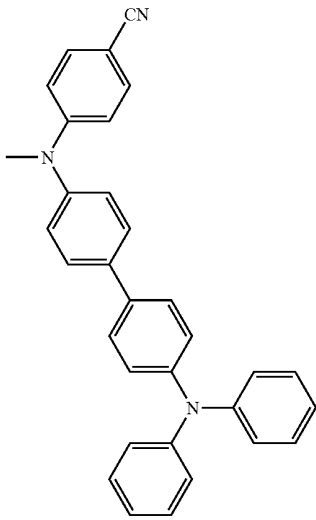

98

-continued

271

5

10

15

20

25  
272

30

35

40

45  
273

50

55

60

65

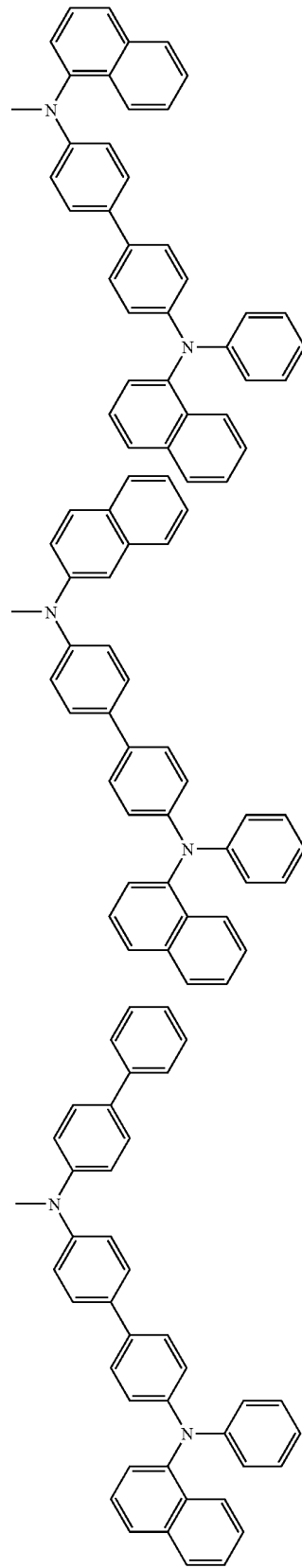

274

275

276

**99**  
-continued

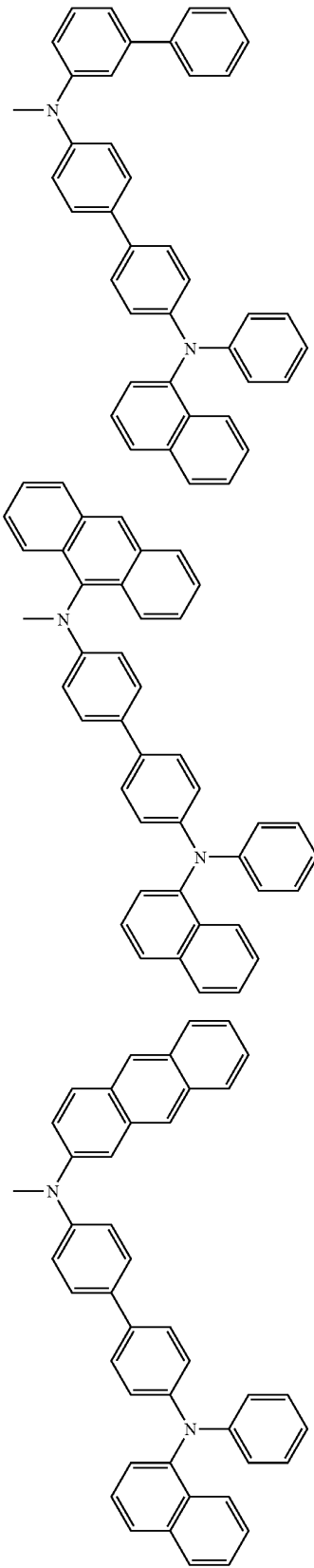

277

5

10

15

20

278

25

30

35

40

279

45

50

55

60

65

**100**  
-continued



280

281

101

continued

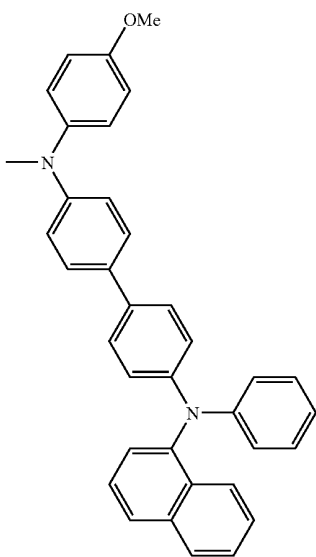
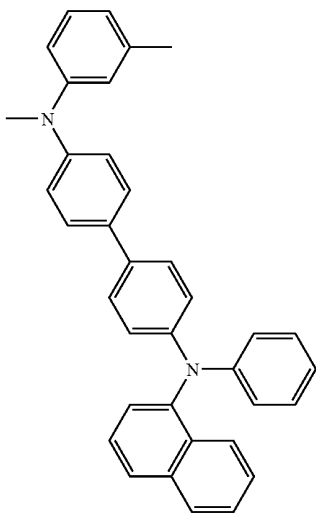
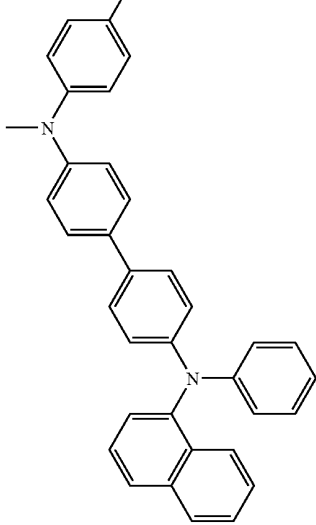

102

-continued

282

285

5

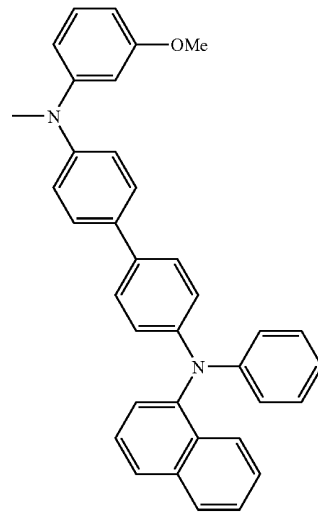

10

15

20

283

286

25

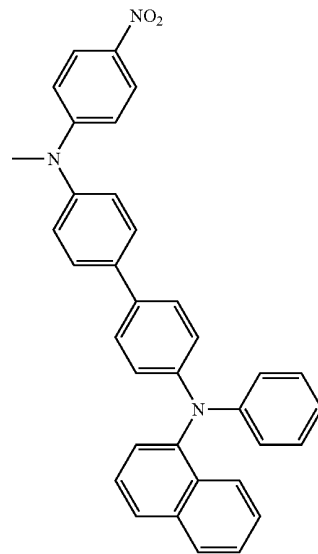

30

35

40

284

45

287

50

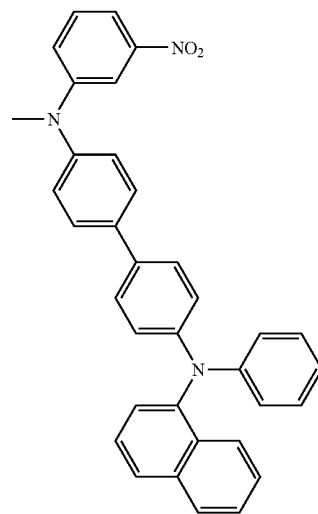

55

60

65

**103**

-continued

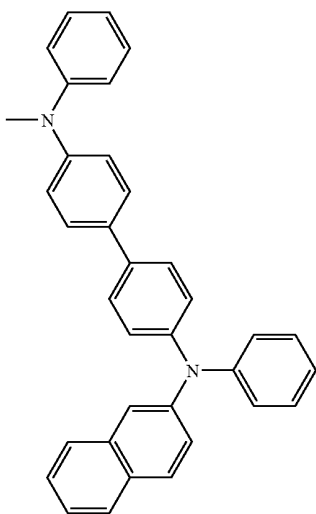
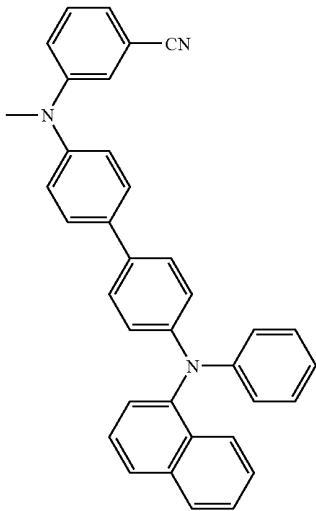
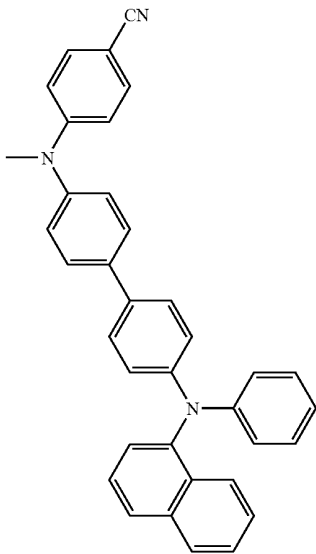

**104**

-continued

288

5

10

15

20

289

25

30

35

40

45

290

50

55

60

65

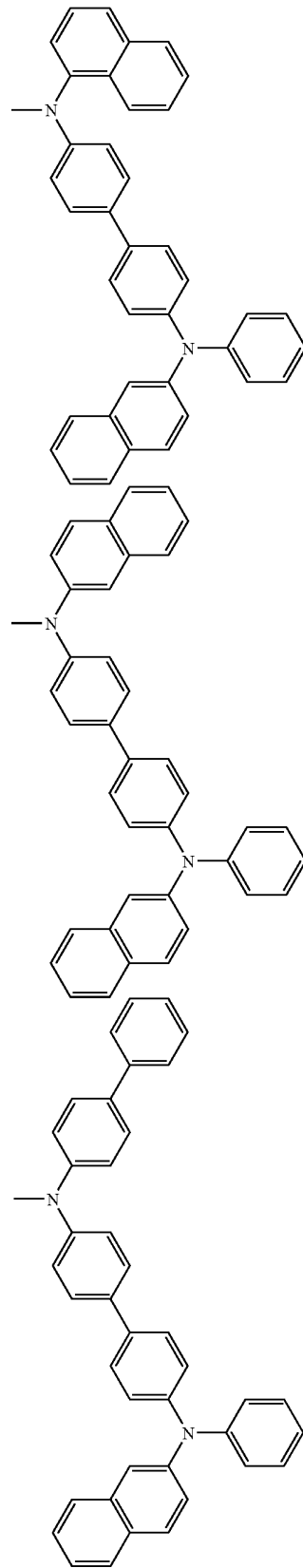

291

292

293



107

-continued

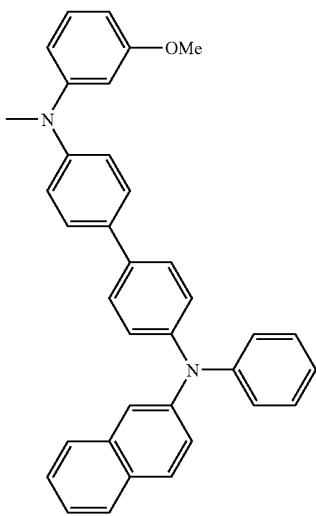
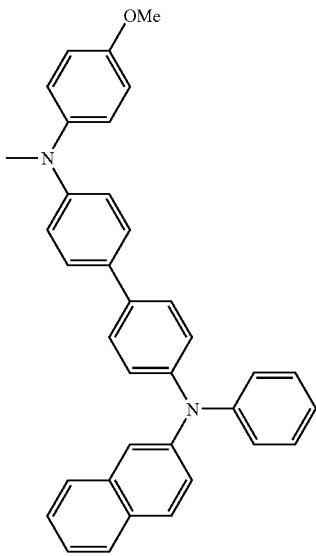
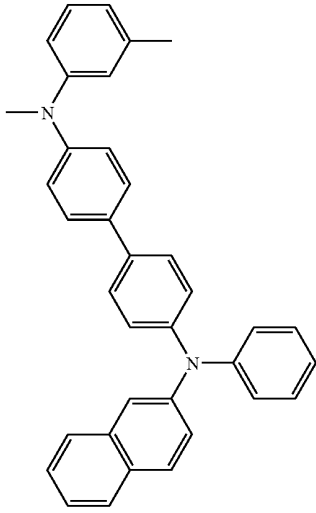

108

-continued

300

303

5

10

15

20

301

25

30

35

40

45

302

50

55

60

65

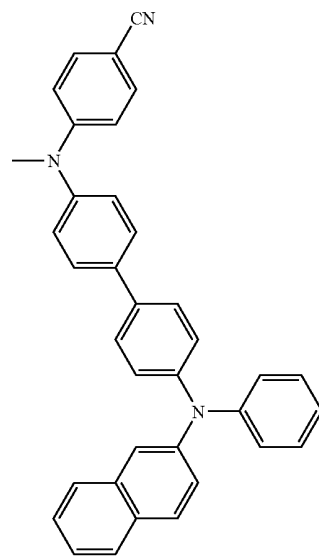
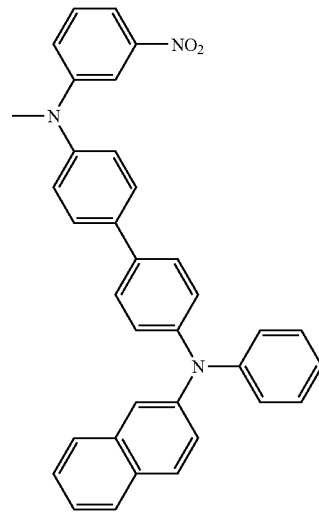
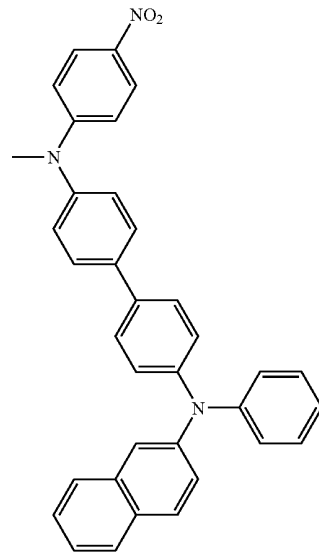

304

305

109

-continued

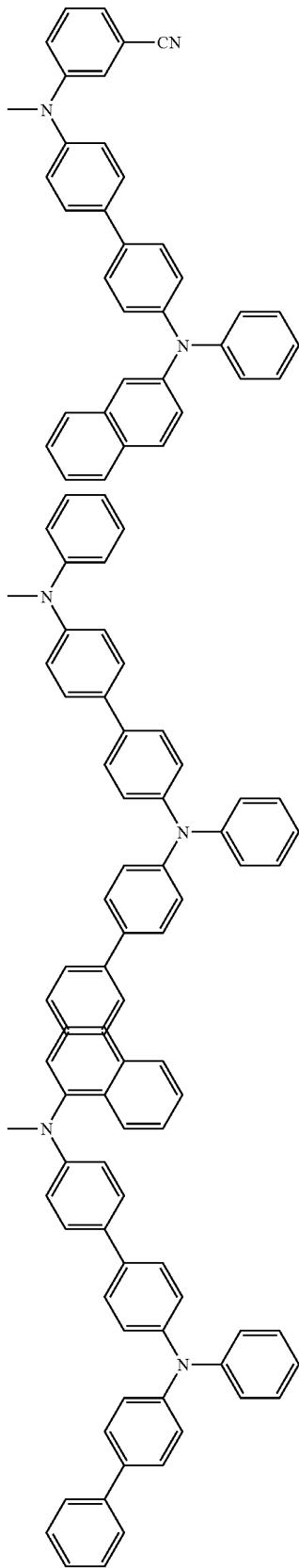

110

-continued

306

5

10

15

20

307

25

30

35

40

308

45

50

55

60

65

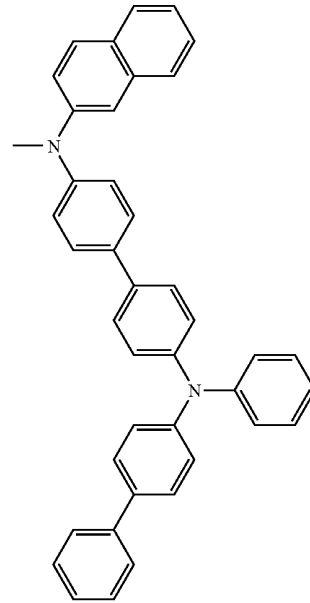

309

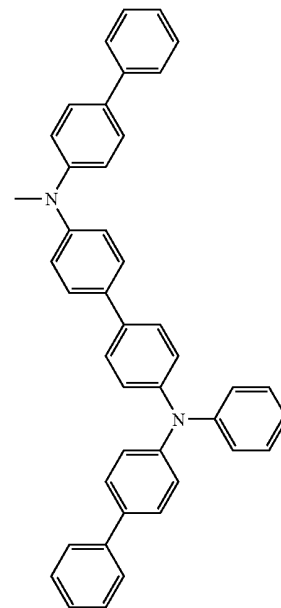

310



**113**  
-continued

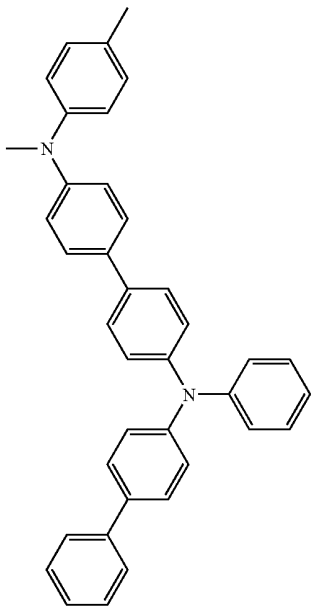
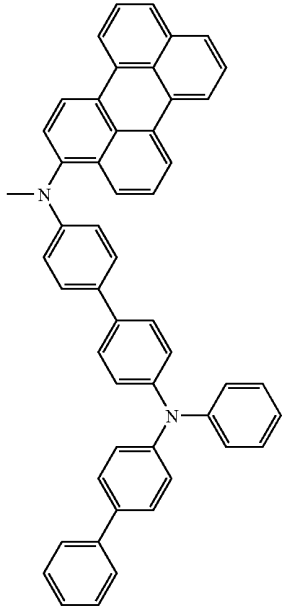

**114**  
-continued

5

315

10

15

20

25

30

35

40

316

45

50

55

60

65

317

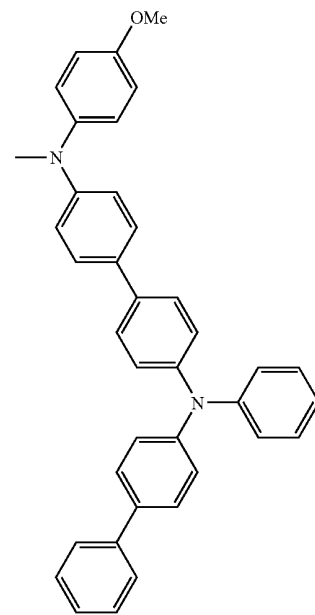
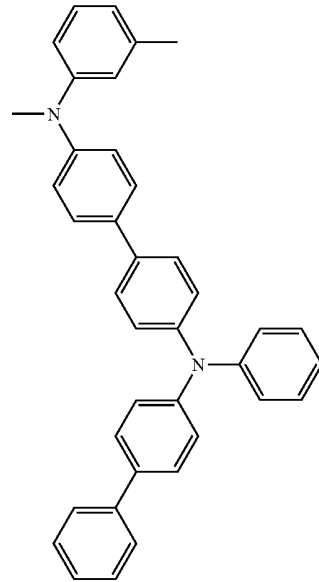

318

**115**  
-continued

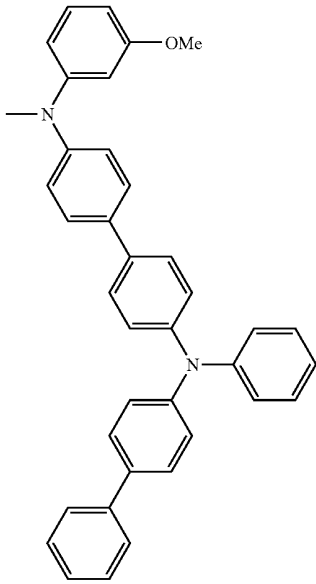

5

319

10

15

20

25

30

35

40

320

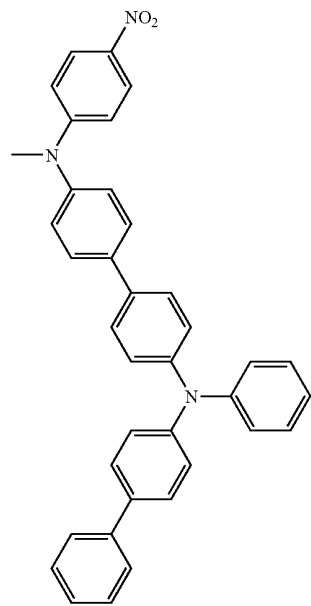

45

50

55

60

65

**116**  
-continued

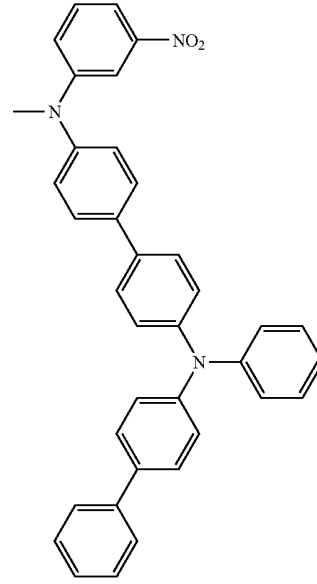

321

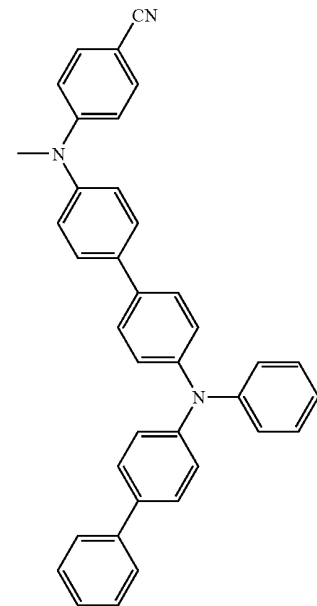

322

**9**  
-continued

[Formula 7]

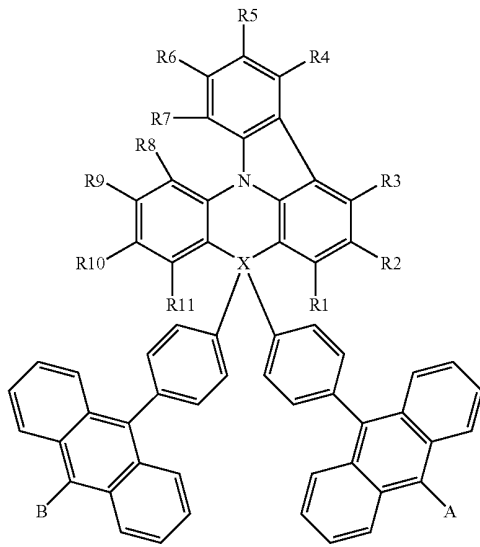

In the above Formulae 2 to 7, X, R1 to R11, A and B are as defined in Formula 1.

Examples of A and B groups of Formula 1 are preferably as follows, but are not limited thereto. Combination of the compounds of Formulae 2 to 7 and the following groups can form various derivative compounds.

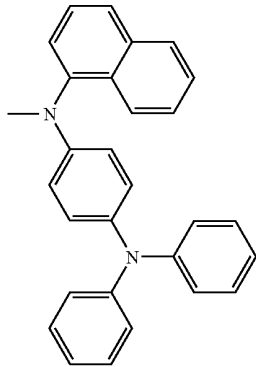
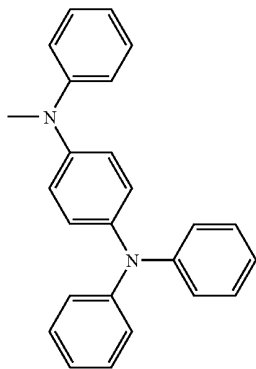

**10**  
-continued

5  
10  
15  
20  
25  
30  
35  
40  
45  
50  
55  
60  
65

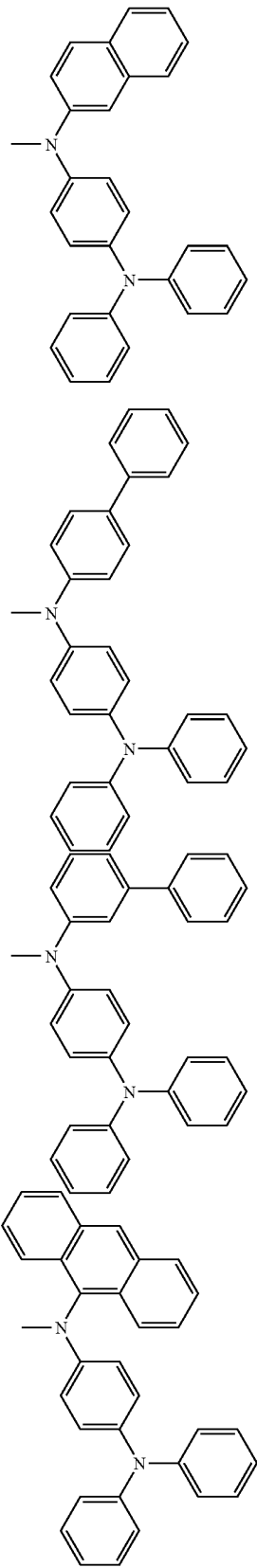

3

4

5

6

117  
-continued

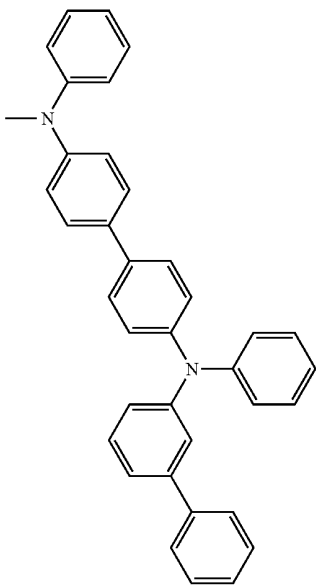
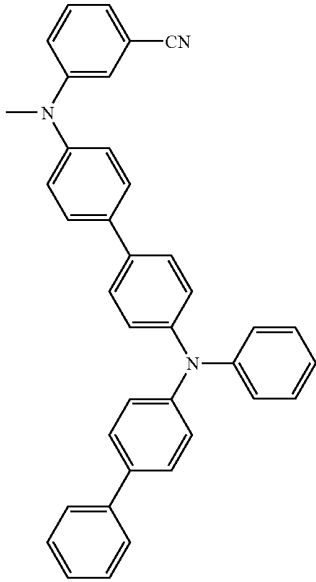

118  
-continued

5

323

10

15

20

25

30

35

40

324

45

50

55

60

65

325

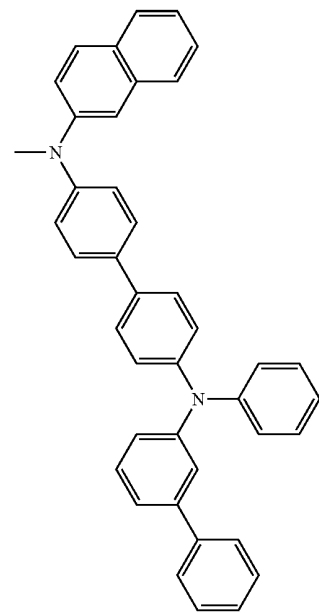
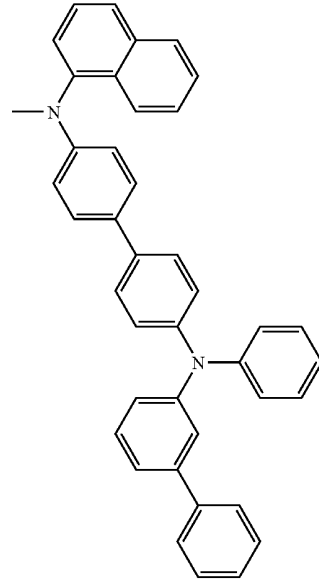

326

119  
-continued

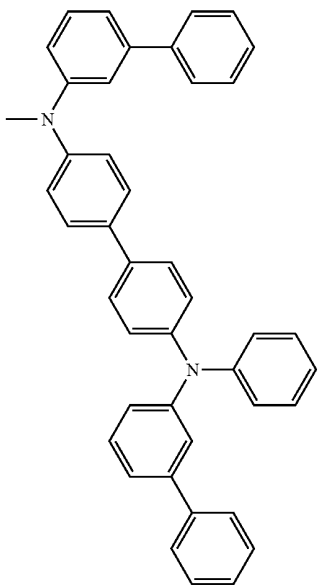
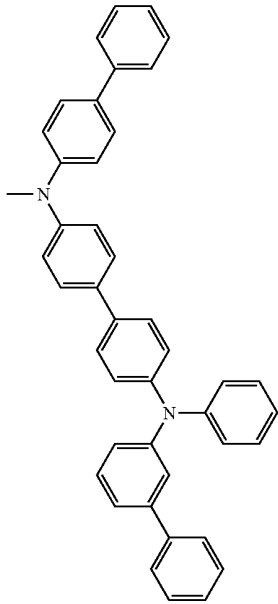

120  
-continued

5

327

10

15

20

25

30

35

40

328

45

50

55

60

65

329

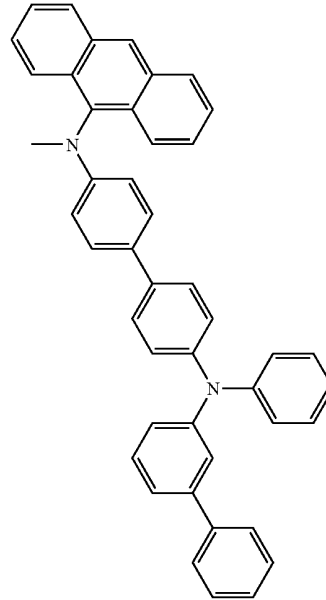

330

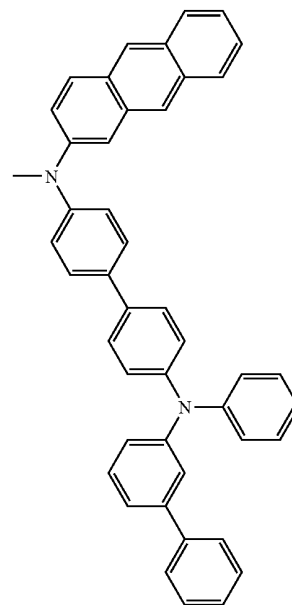

**121**  
-continued

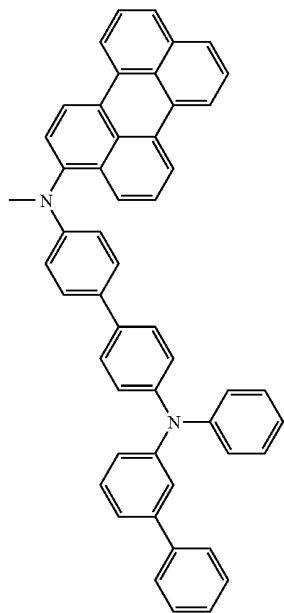
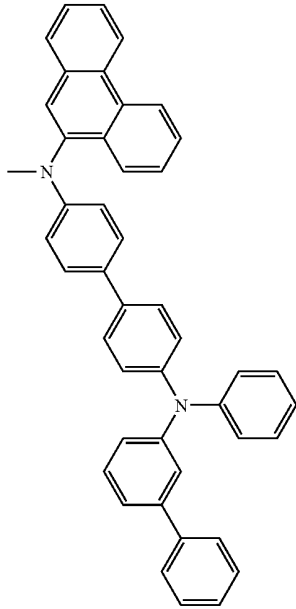

**122**  
-continued

5

331

10

15

20

25

30

35

40

332

45

50

55

60

65

333

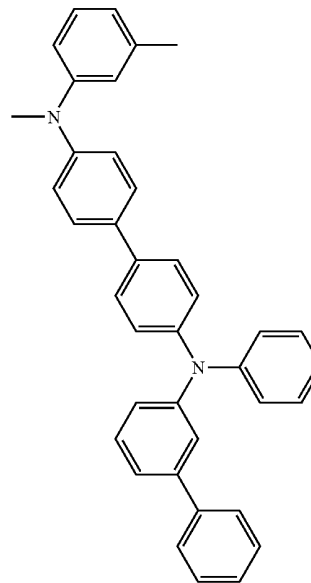
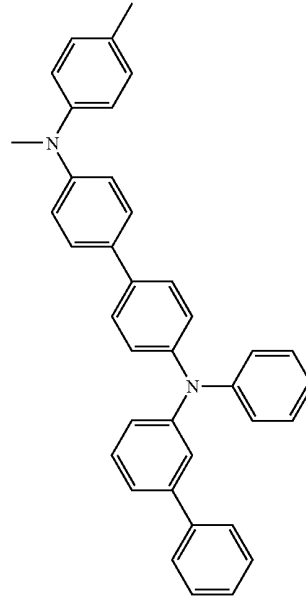

**123**  
-continued

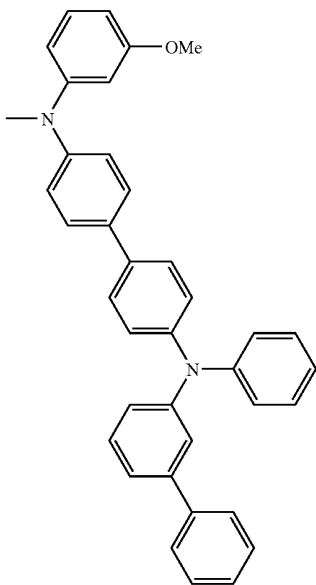
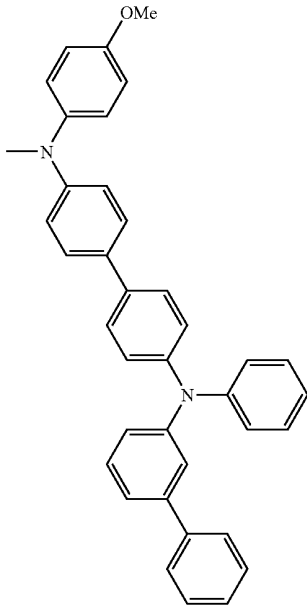

**124**  
-continued

5

335

10

15

20

25

30

35

40

336

45

50

55

60

65

337

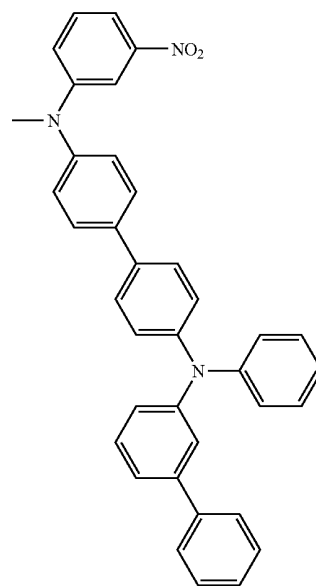
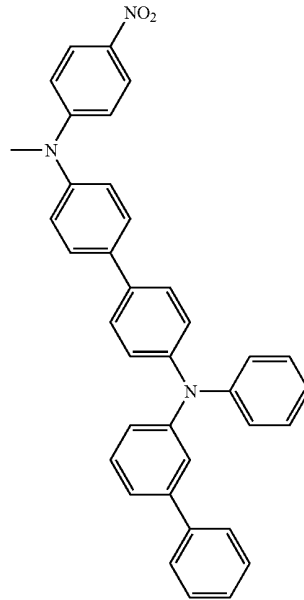

338

**125**  
-continued

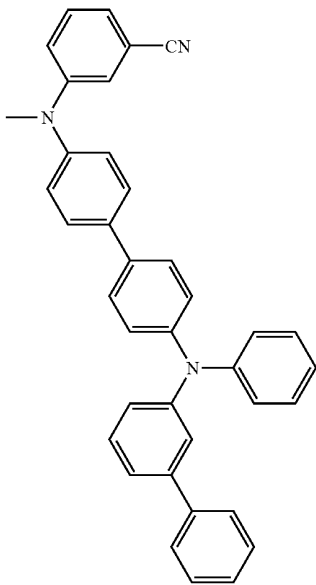
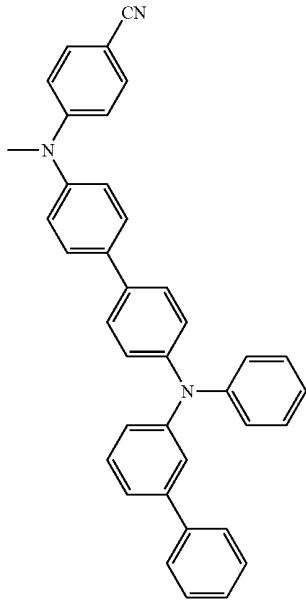

**126**  
-continued

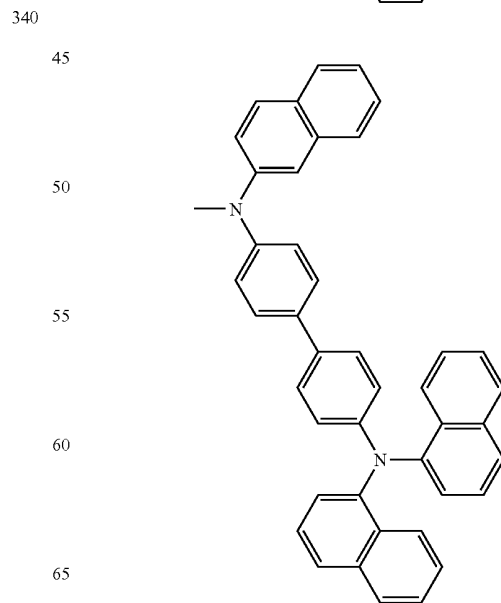
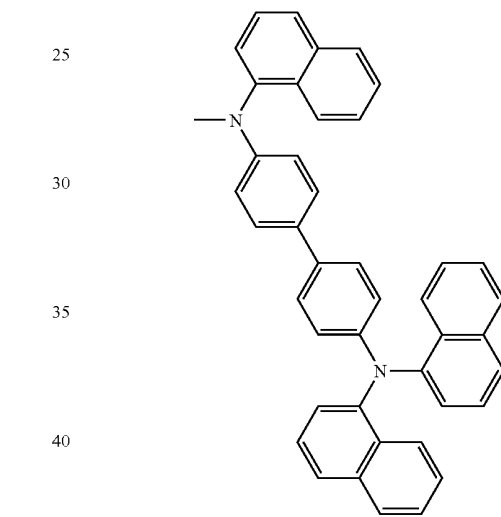
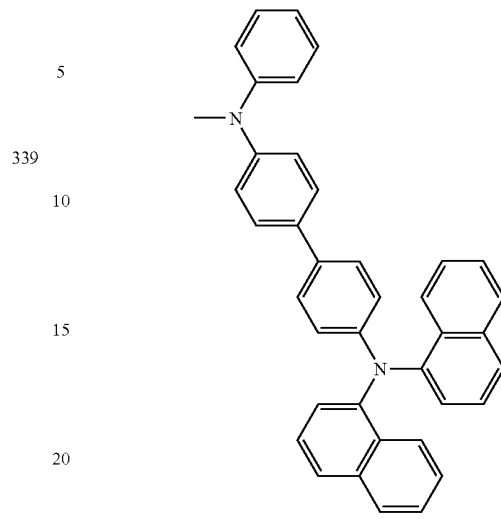

341

342

343



**129**

-continued

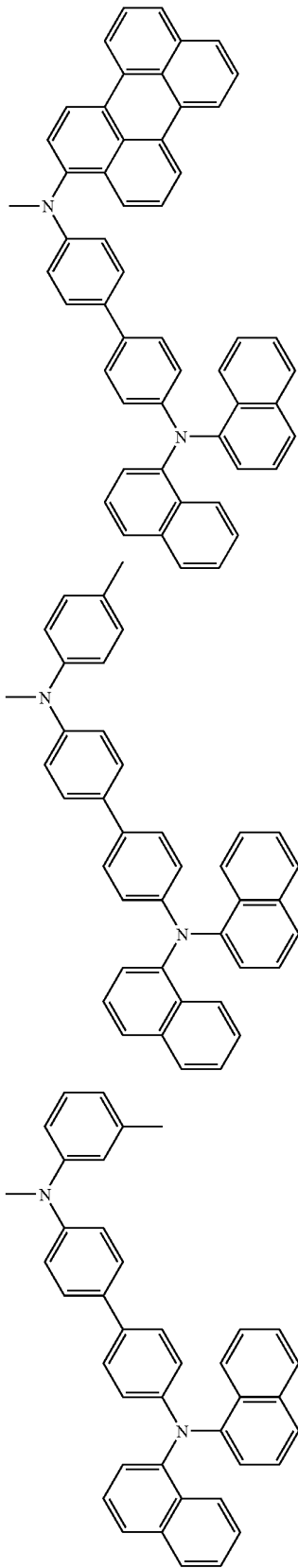

**130**

-continued

349

352

5

10

15

20

350

25

30

35

40

45

351

50

55

60

65

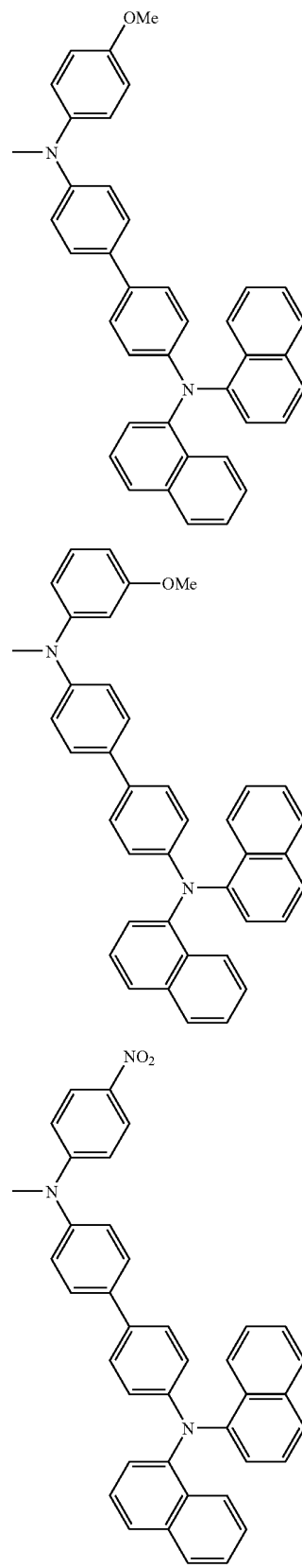

131

-continued

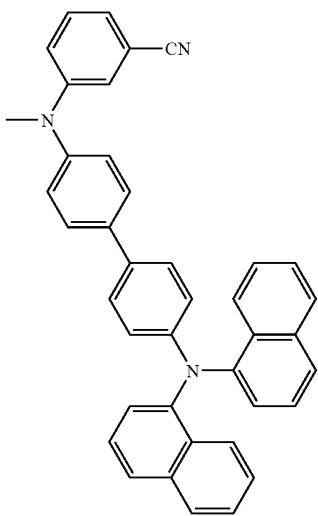
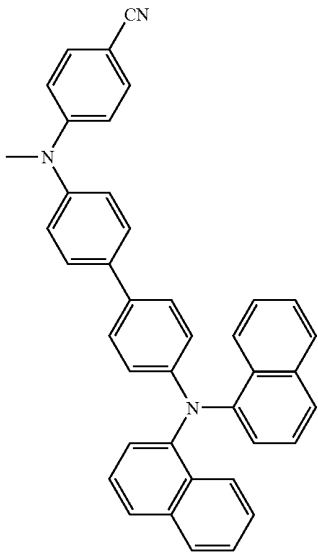
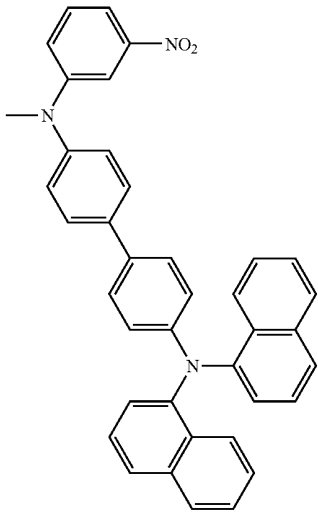

132

-continued

355

358

5

10

15

20

356

359

25

30

35

40

45

360

357

50

55

60

65

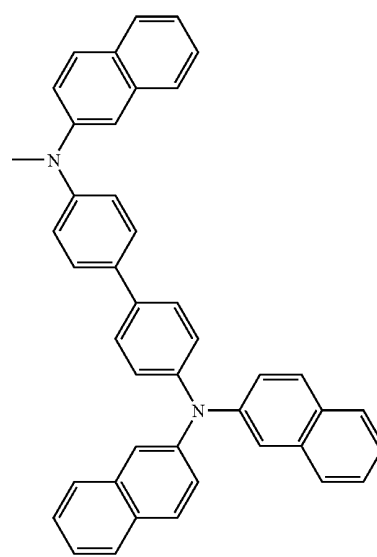
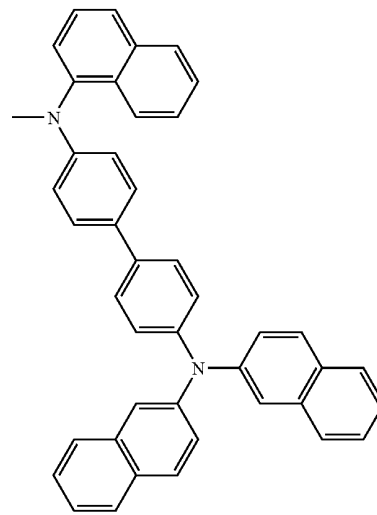
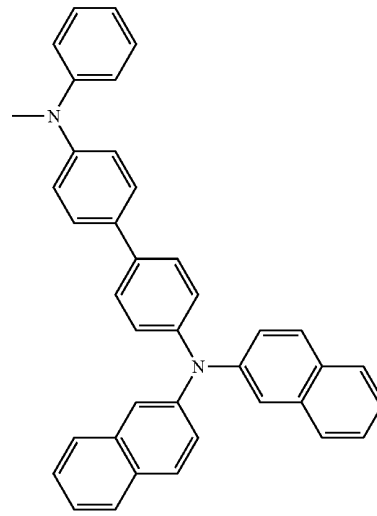

133

-continued

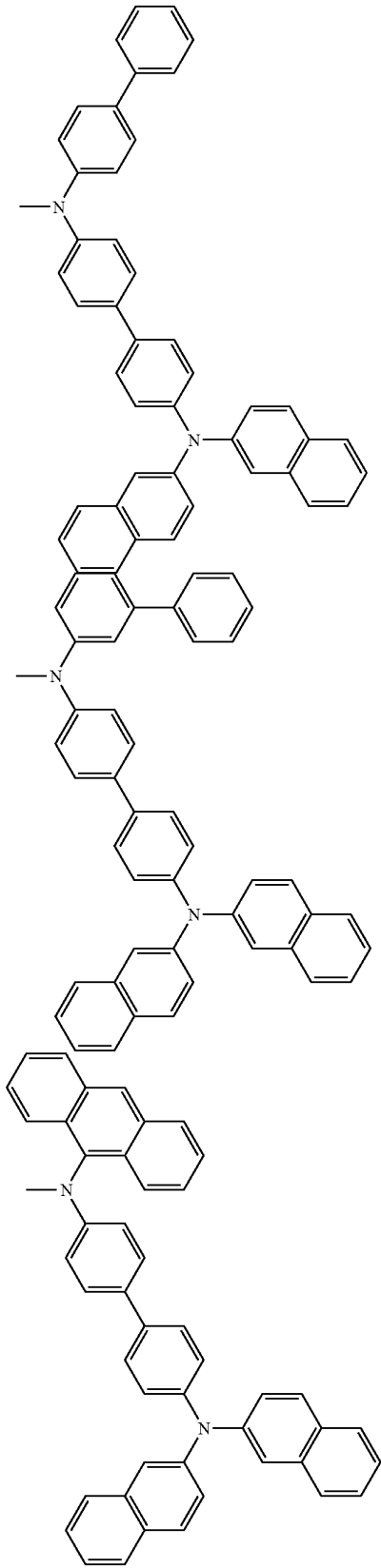

134

-continued

361

5

10

15

20

25

30

35

40

362 45

50

55

60

65

364

365

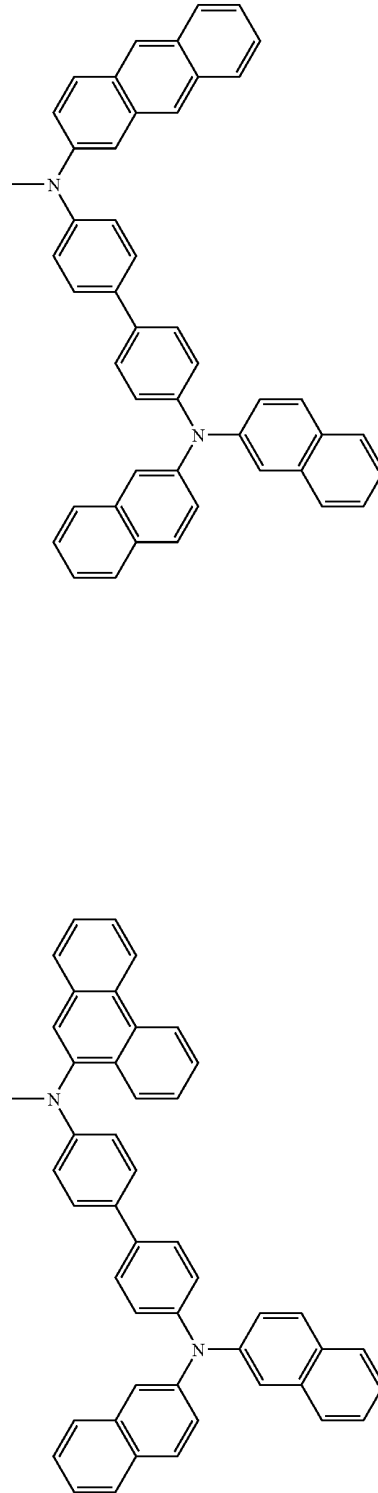

**135**

-continued

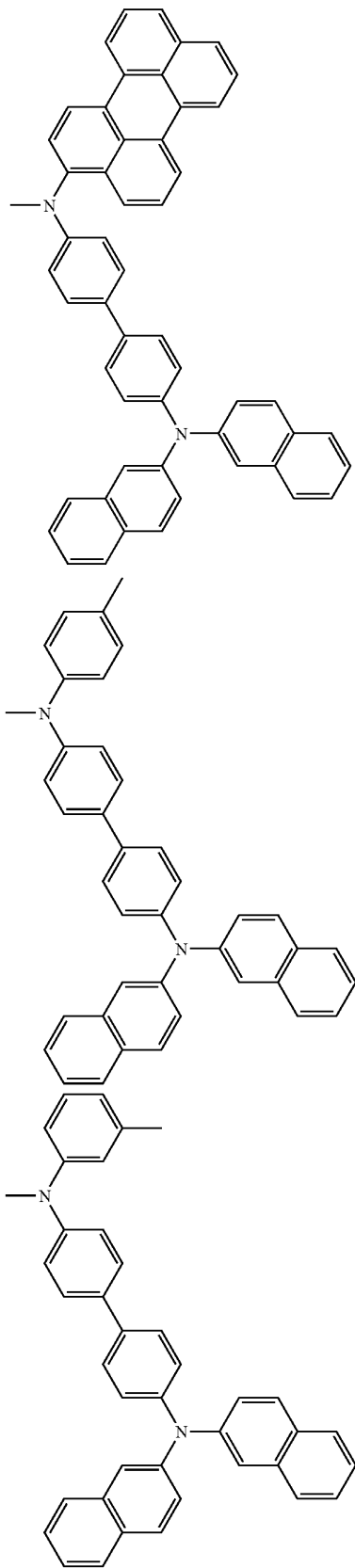

**136**

-continued

366

369

5

10

15

20

367 25

370

30

35

40

45

368

371

50

55

60

65

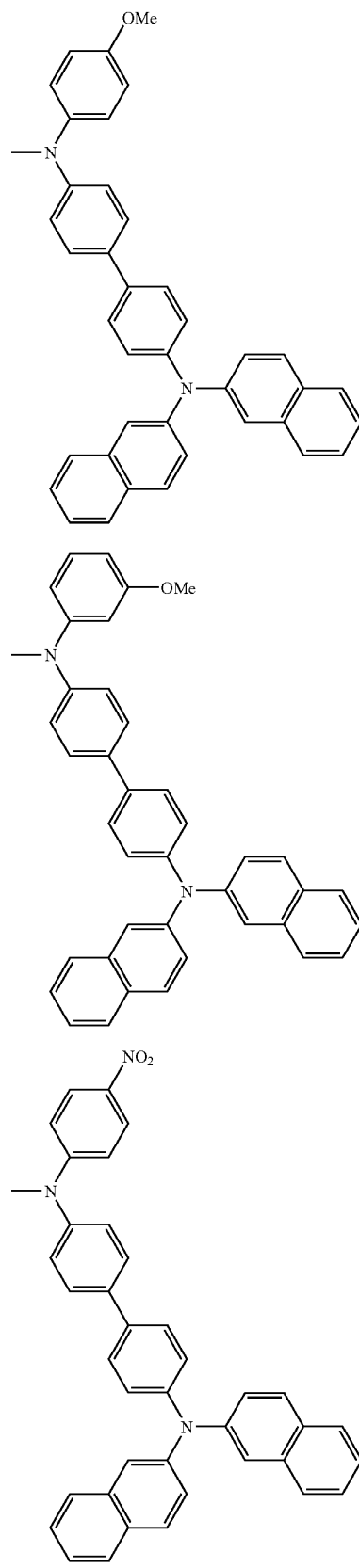

**11**

-continued

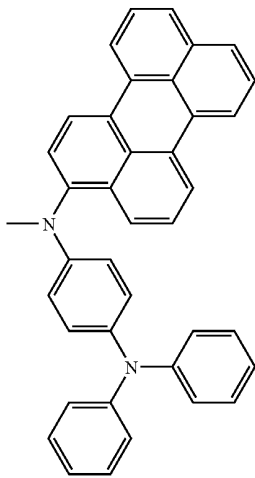
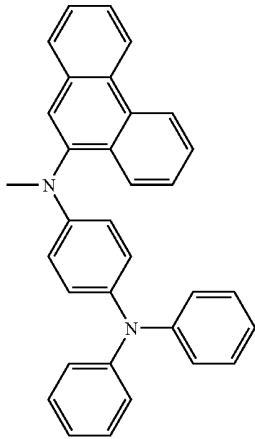
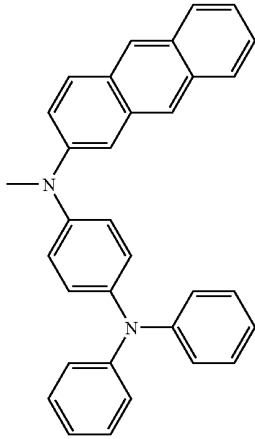

**12**

-continued

7

5

10

15

20

8 25

30

35

40

45

9

50

55

60

65

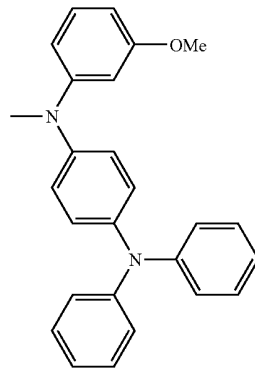
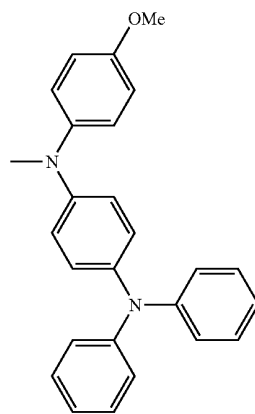
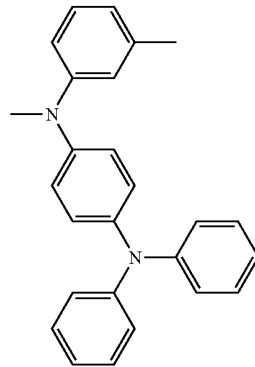
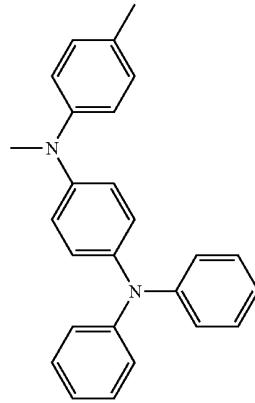

10

11

12

13

137

-continued

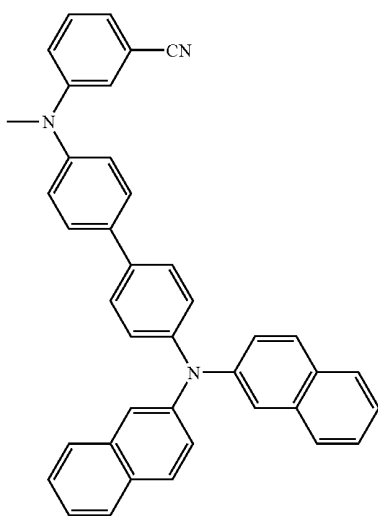
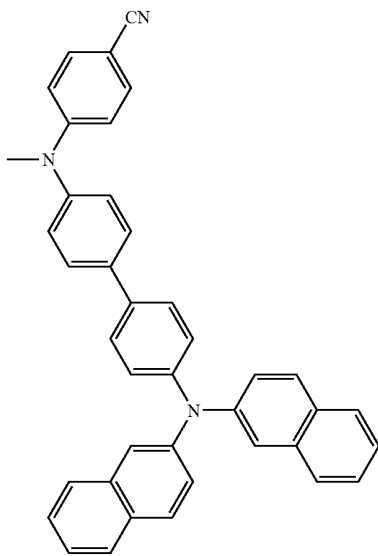
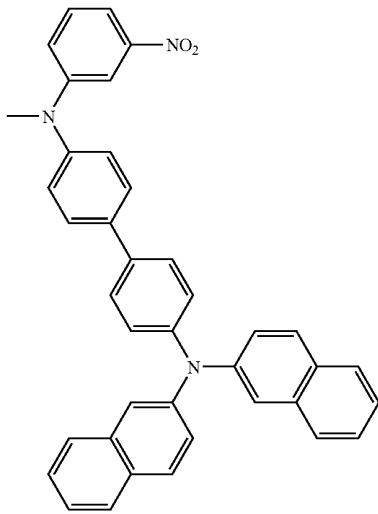

372

5

10

15

20

373

25

30

35

40

45

374

50

55

60

65

138

-continued

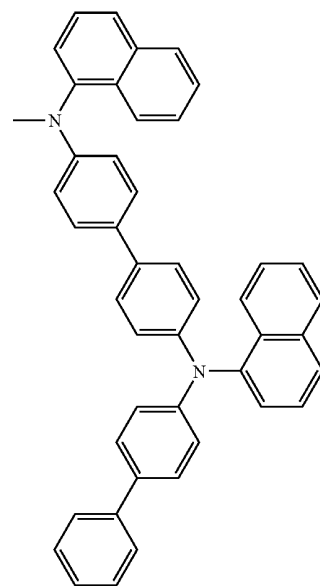
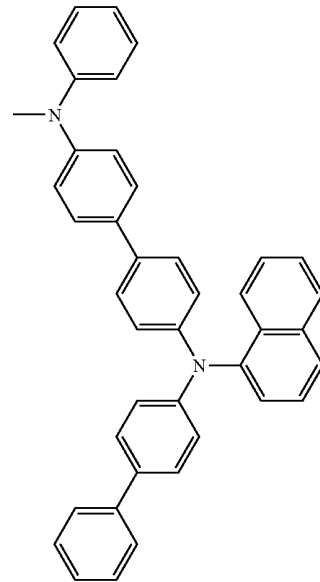

375

376

**139**  
-continued

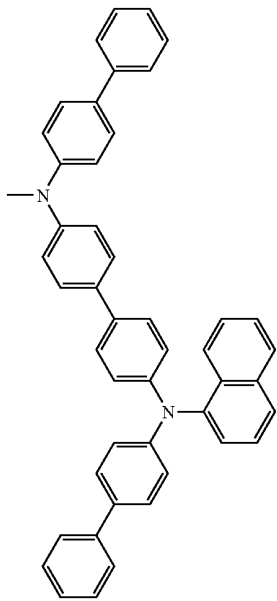
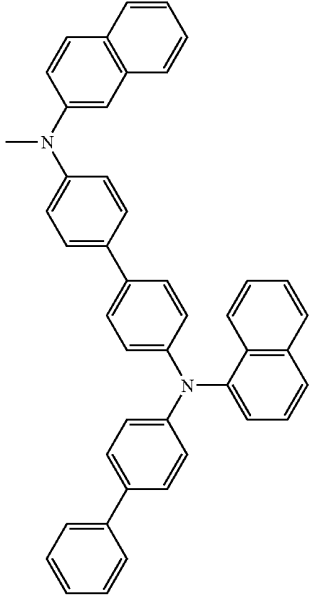

**140**  
-continued

5

377

10

15

20

25

30

35

40

378

45

50

55

60

65

379

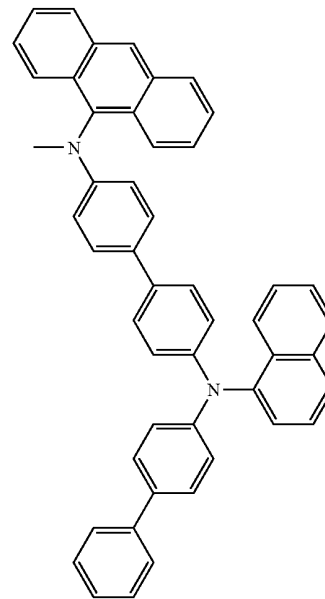
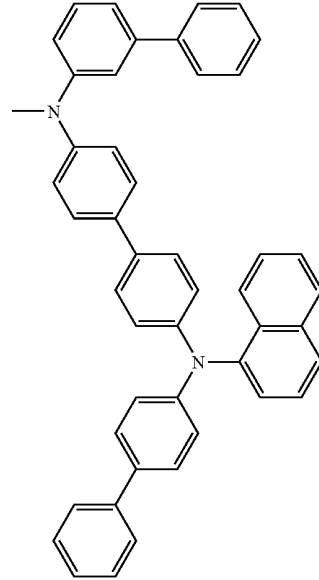

380

**141**  
-continued

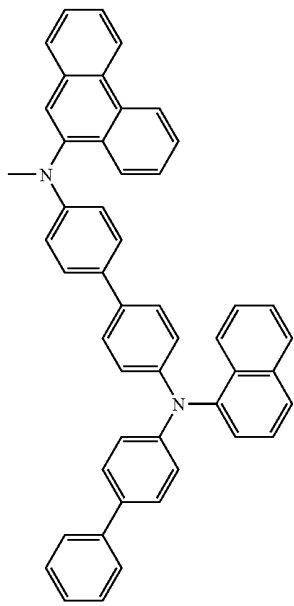
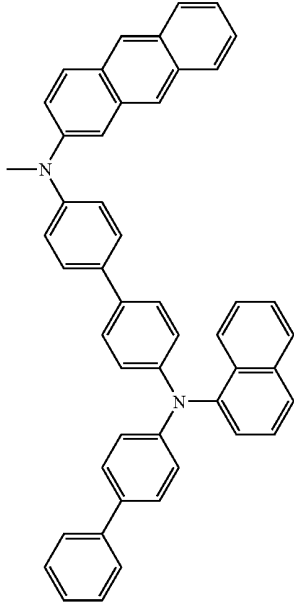

**142**  
-continued

5

381

10

15

20

25

30

35

40

382

45

50

55

60

65

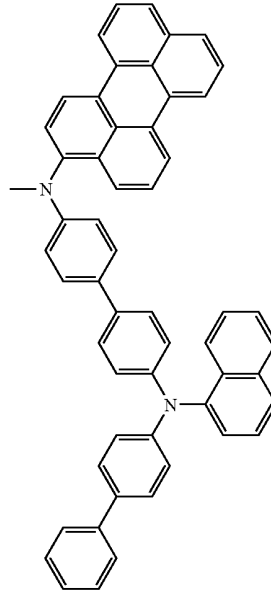

383

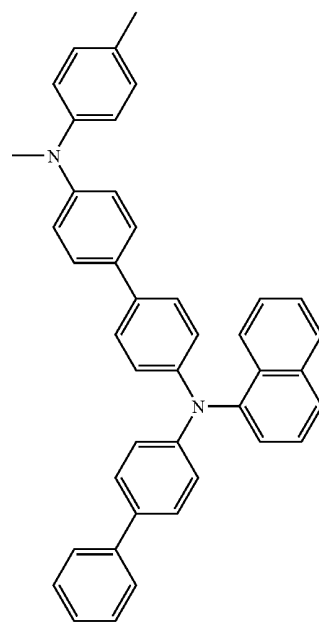

384

**143**  
-continued

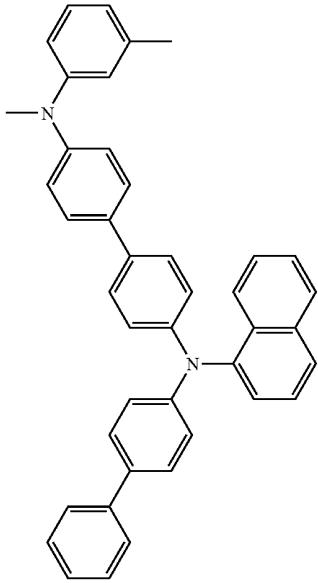

5

385

10

15

20

25

30

35

40

**144**  
-continued

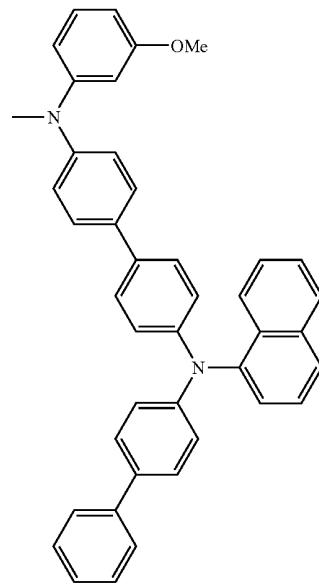

387

386

45

50

55

60

65

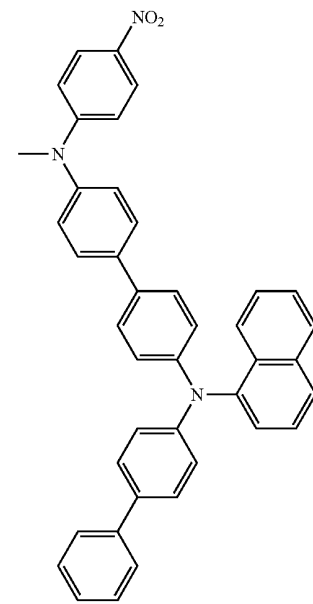
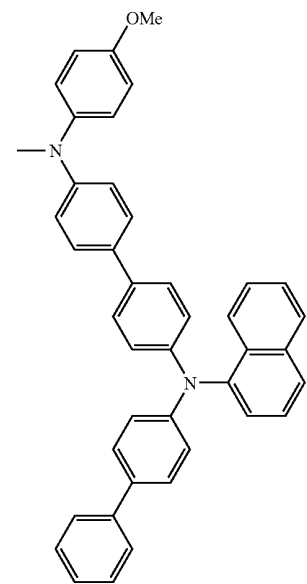

388

**145**  
-continued

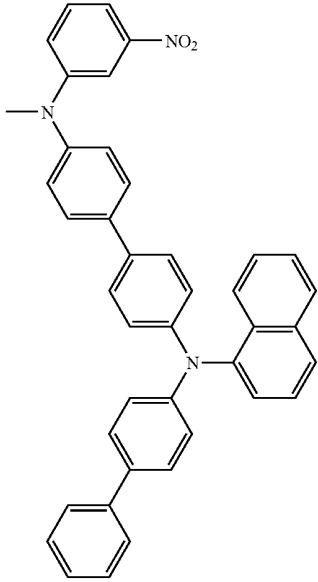

5

389

10

15

20

25

30

35

40

390

45

50

55

60

65

**146**  
-continued

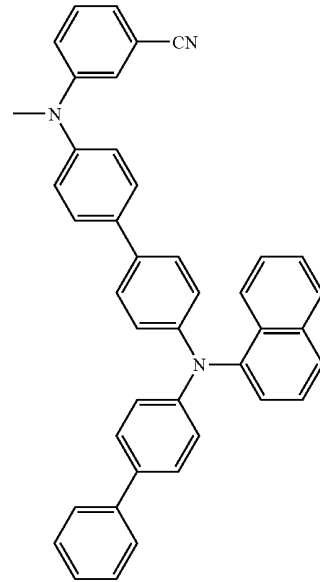

391

392

**147**  
-continued

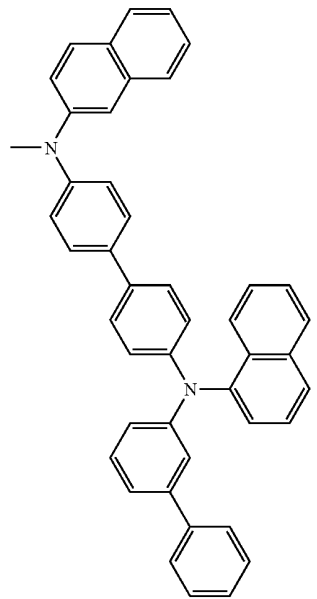
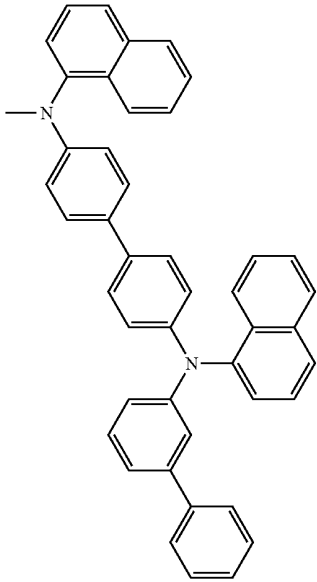

**148**  
-continued

5

393

10

15

20

25

30

35

40

394

45

50

55

60

65

395

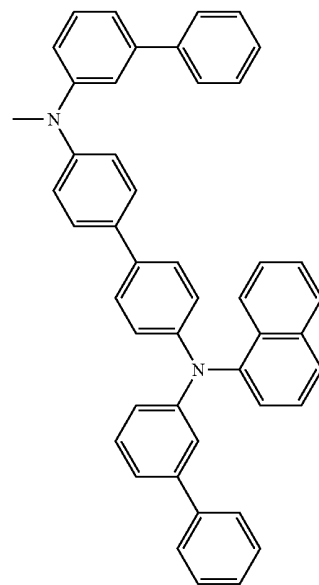
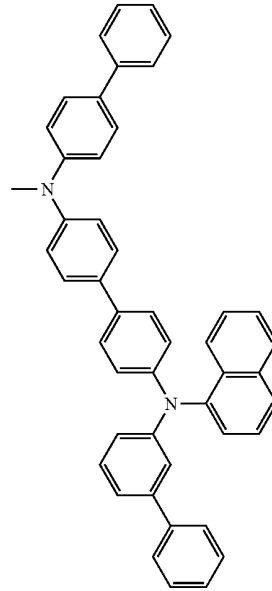

396

**149**  
-continued

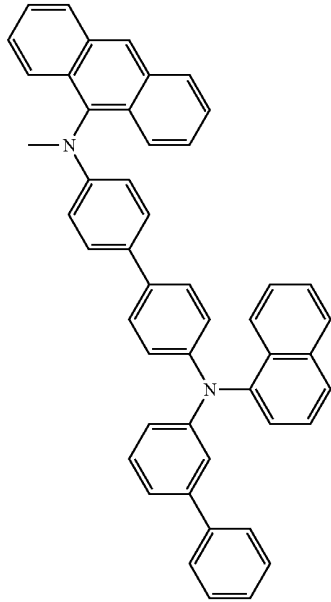

5  
397  
10  
15  
20  
25  
30  
35  
40

**150**  
-continued

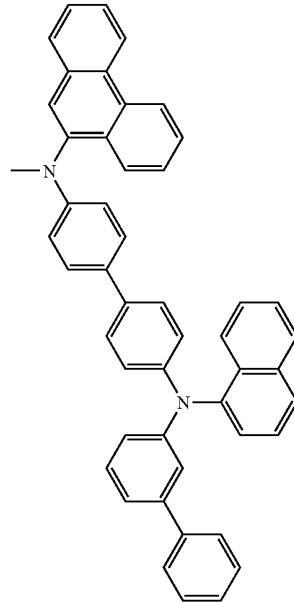

398  
45  
50  
55  
60  
65

399

400

**151**  
-continued

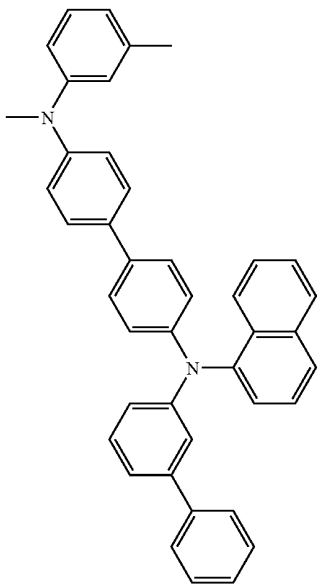
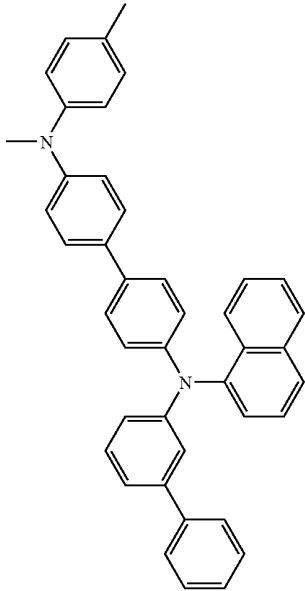

**152**  
-continued

5

401

10

15

20

25

30

35

40

402

45

50

55

60

65

403

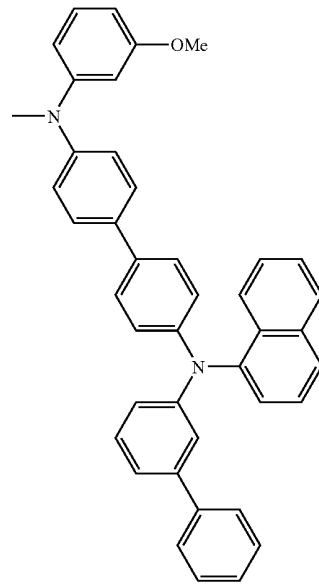
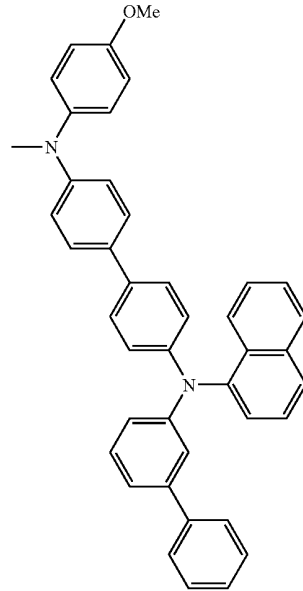

404

**153**  
-continued

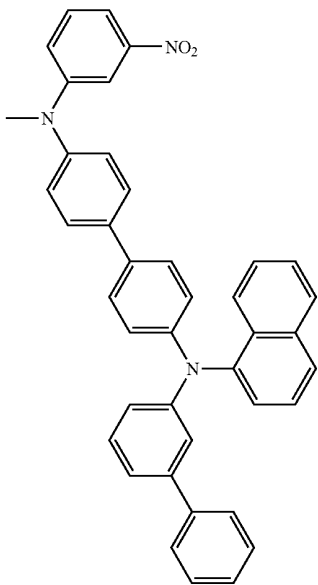
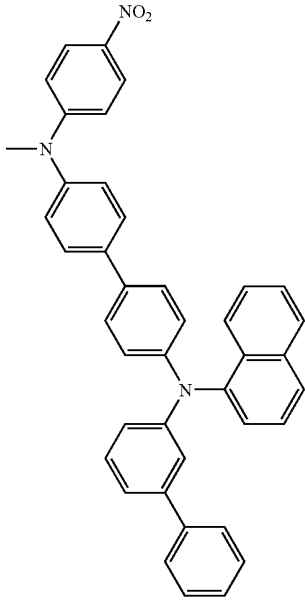

**154**  
-continued

5

405

10

15

20

25

30

35

40

406

45

50

55

60

65

407

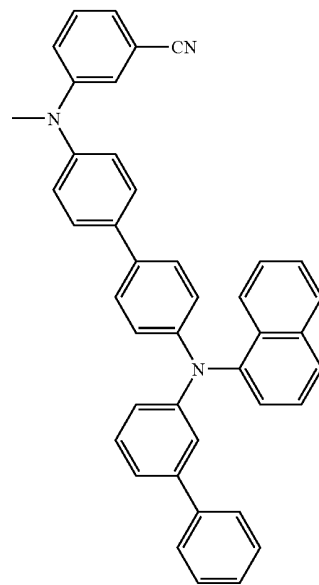
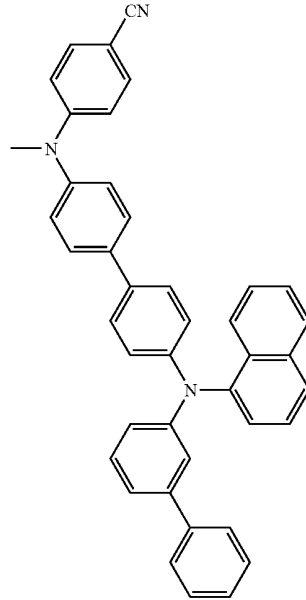

408

**155**  
-continued

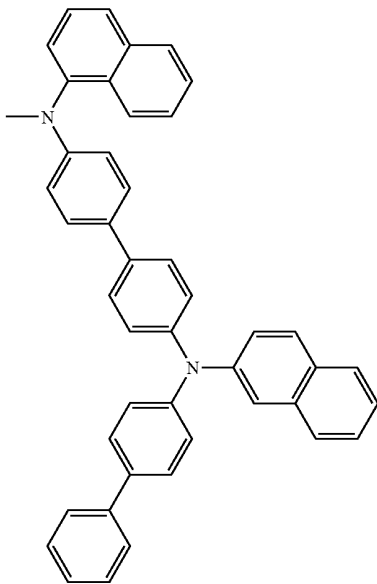
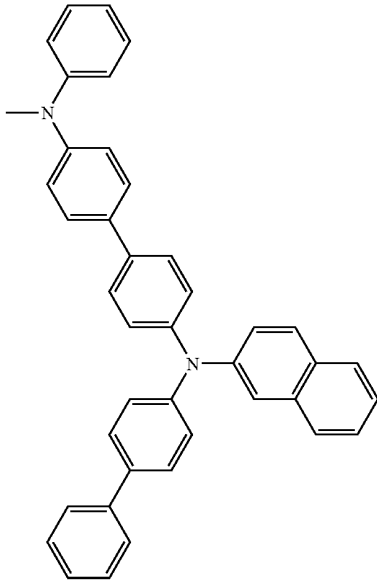

**156**  
-continued

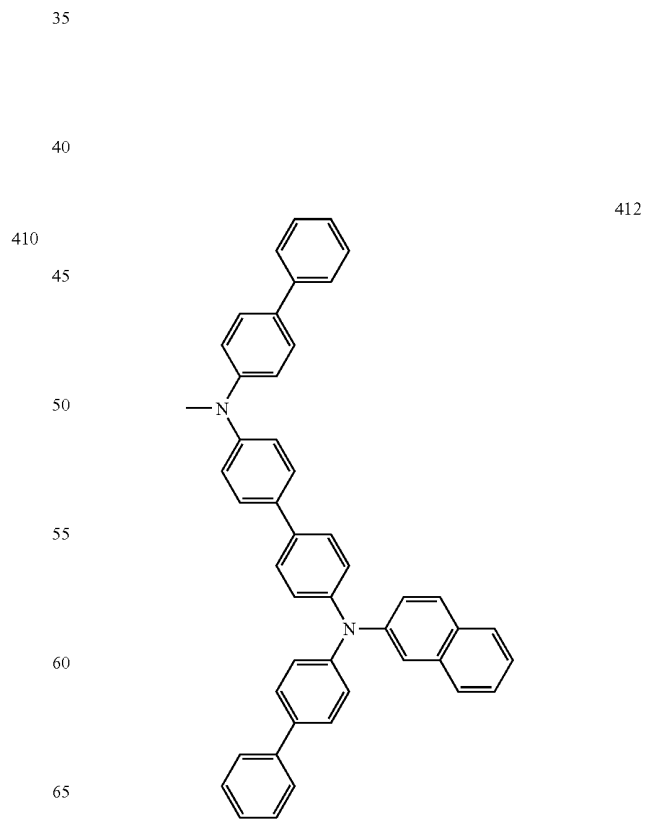
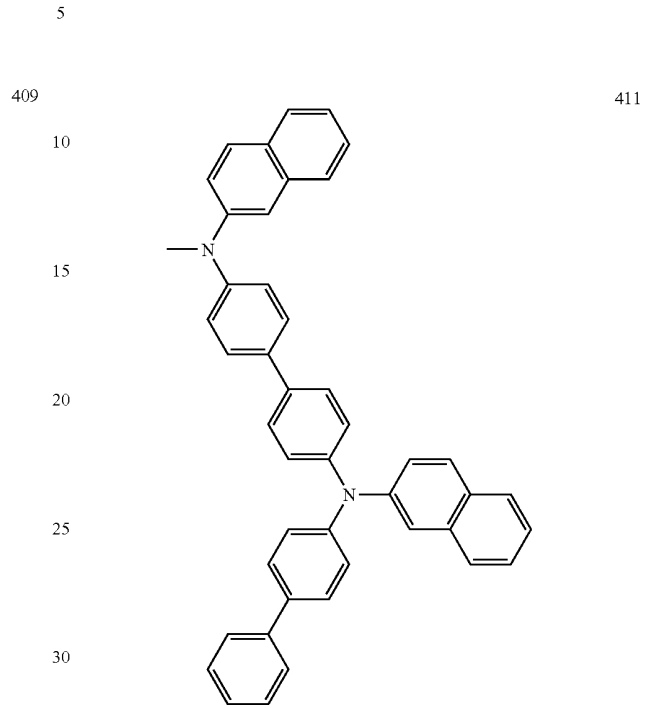

**13**

-continued

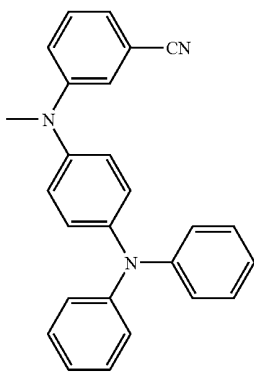
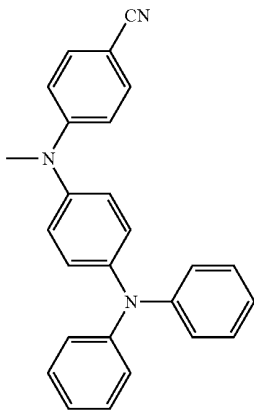
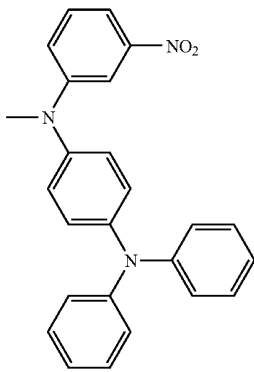
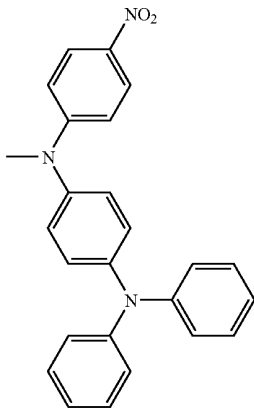

**14**

-continued

14

5

10

15

15

20

25

30

16

35

40

45

50

17

55

60

65

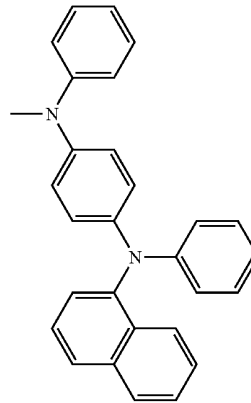

18

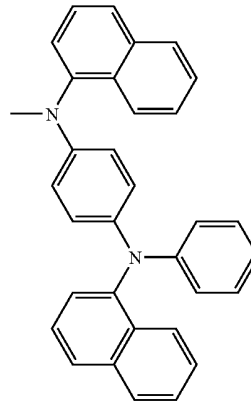

19

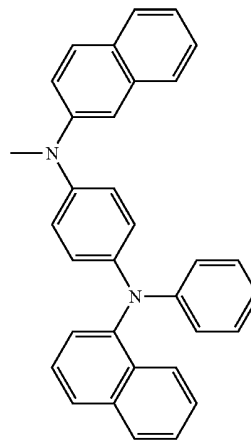

20

**157**  
-continued

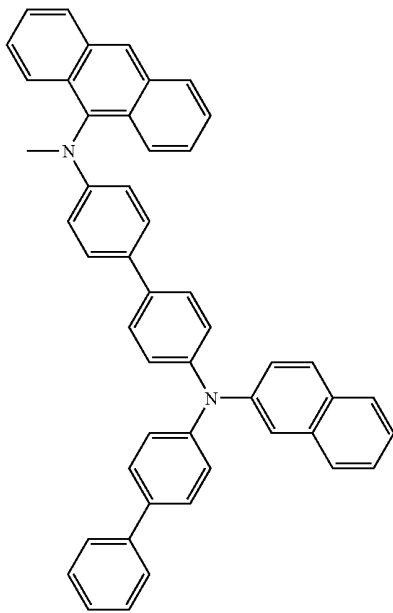
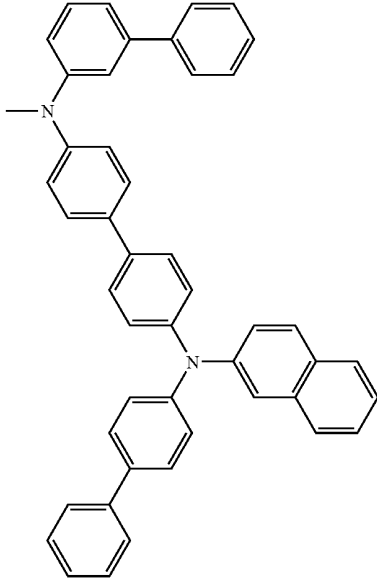

**158**  
-continued

5

413

10

15

20

25

30

35

40

414

45

50

55

60

65

415

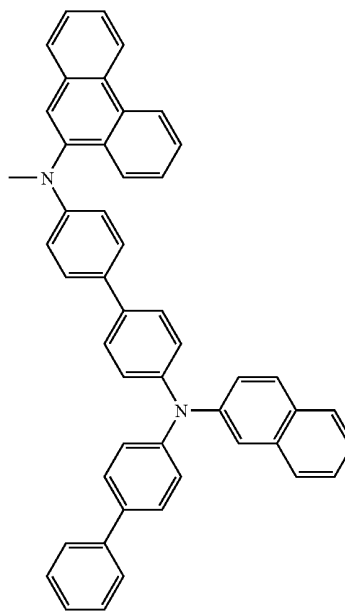
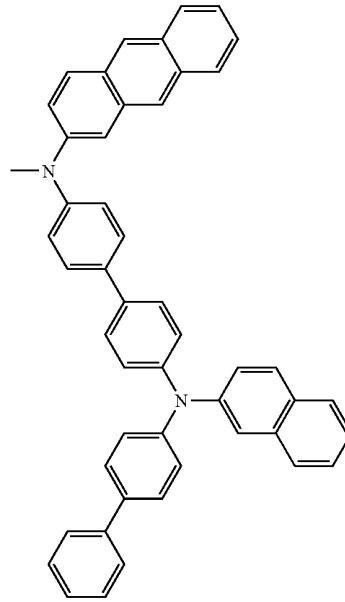

416

**159**  
-continued

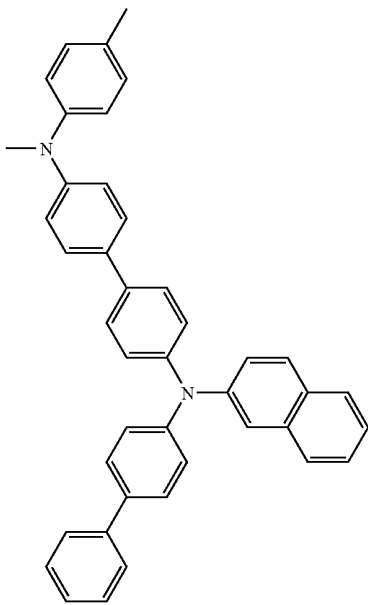
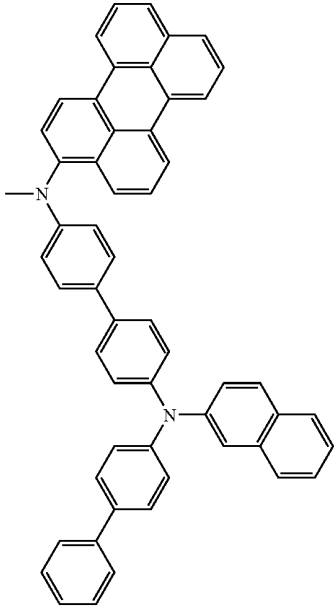

**160**  
-continued

5

417

419

10

15

20

25

30

35

40

418

420

45

50

55

60

65

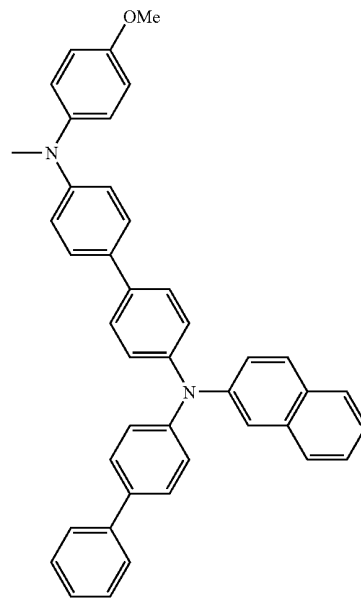
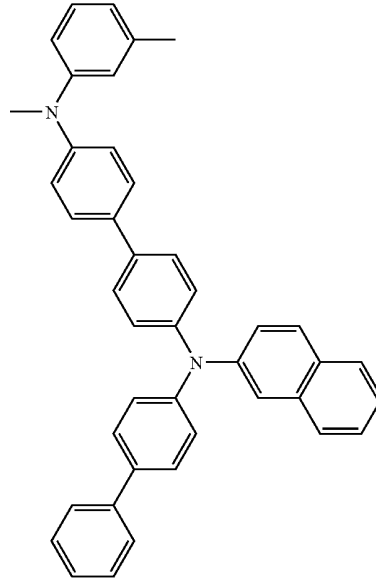

**161**  
-continued

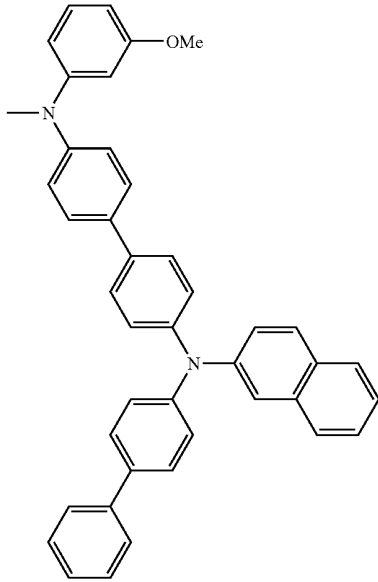

**162**  
-continued

5

10

15

20

25

30

35

40

422

45

50

55

60

65

423

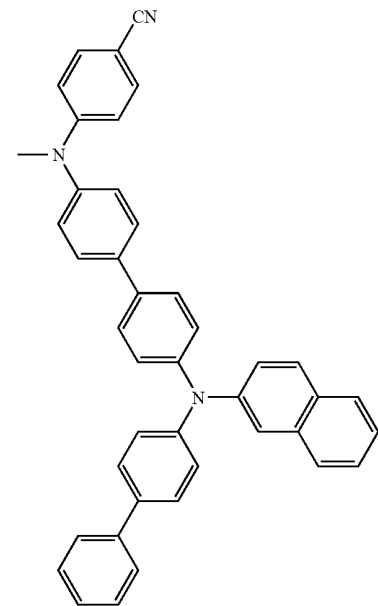
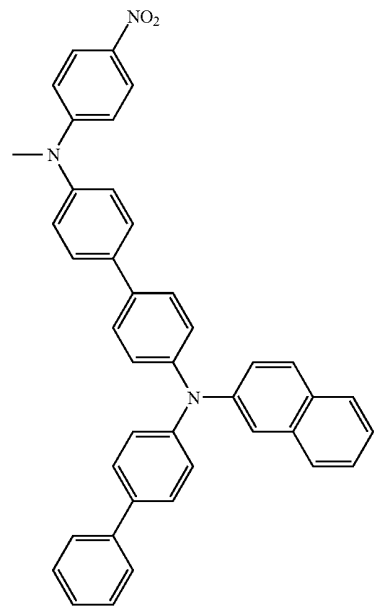
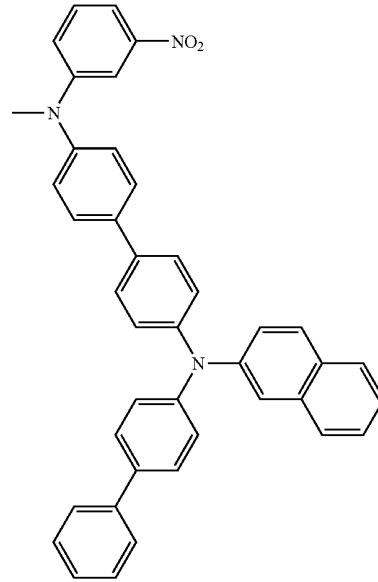

**163**  
-continued

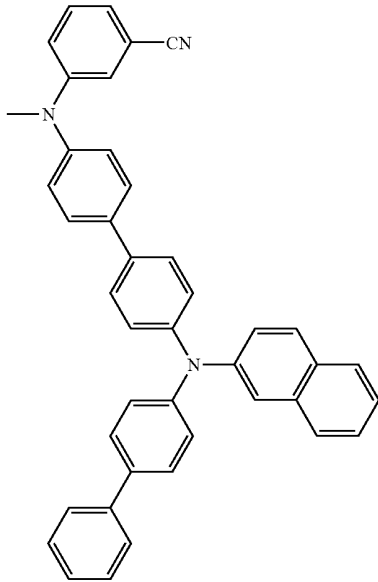

5

425

10

15

20

25

30

35

40

426

45

50

55

60

65

**164**  
-continued

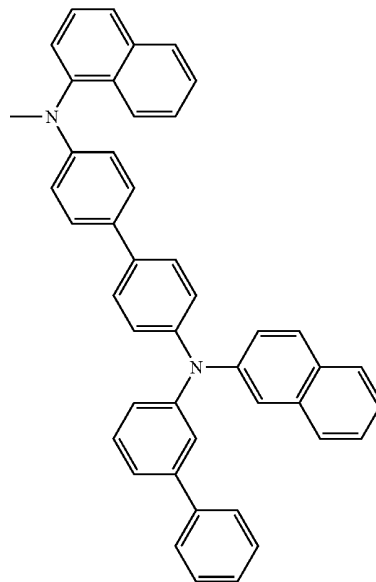

427

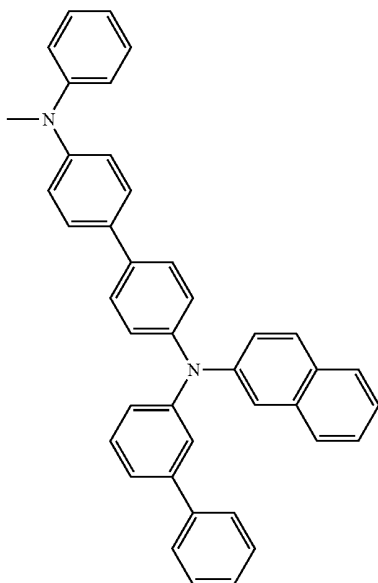

428

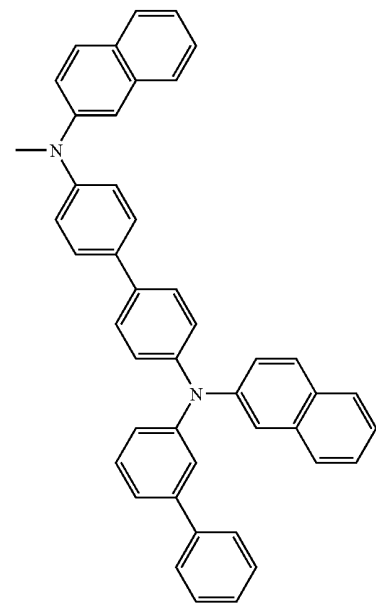

**165**  
-continued

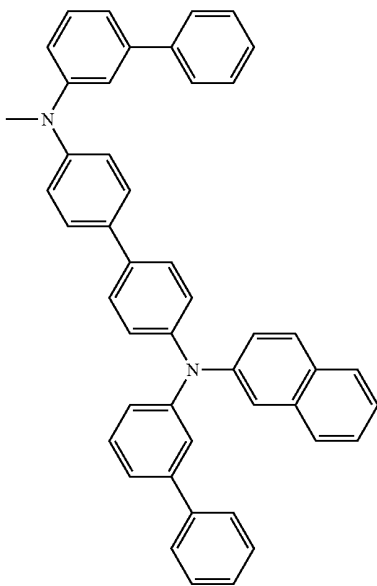
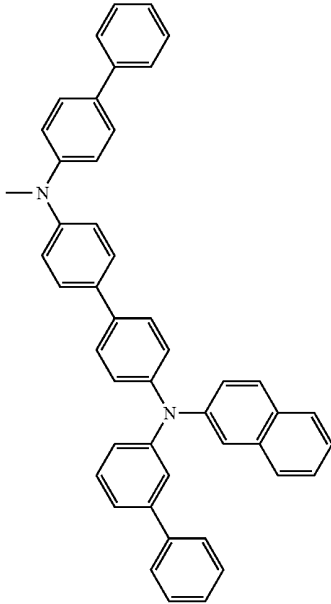

**166**  
-continued

5

429

431

10

15

20

25

30

35

40

430

45

50

55

60

65

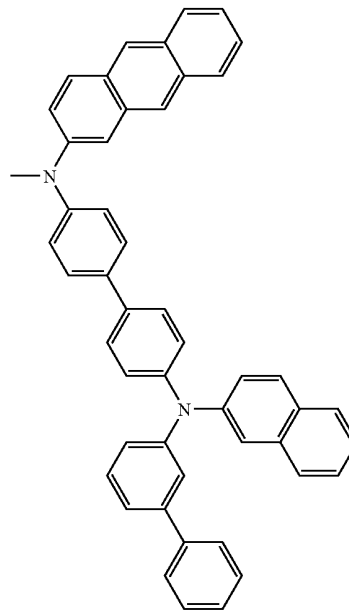
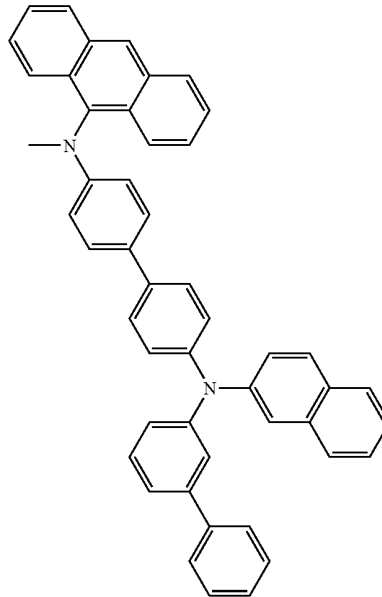

**167**  
-continued

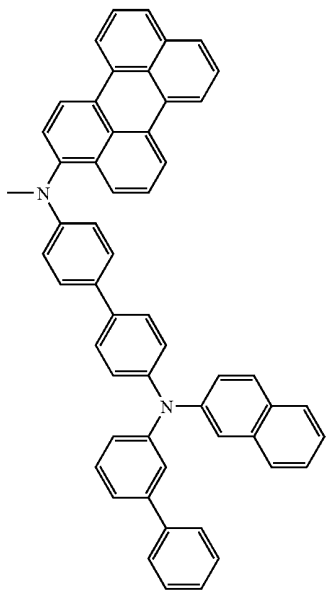
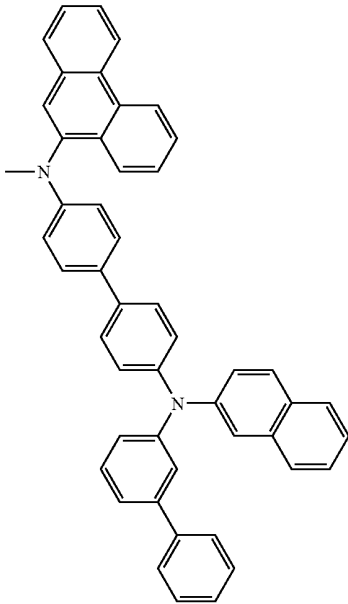

**168**  
-continued

5

433

10

15

20

25

30

35

40

434

45

50

55

60

65

435

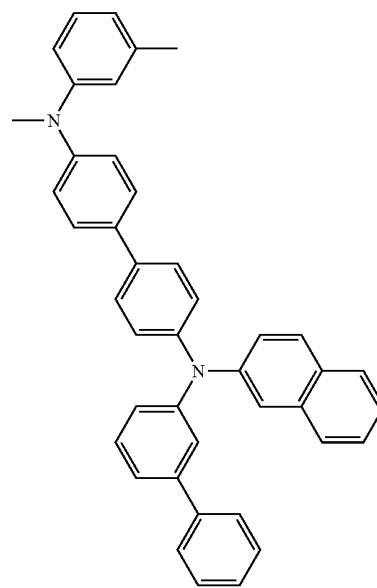
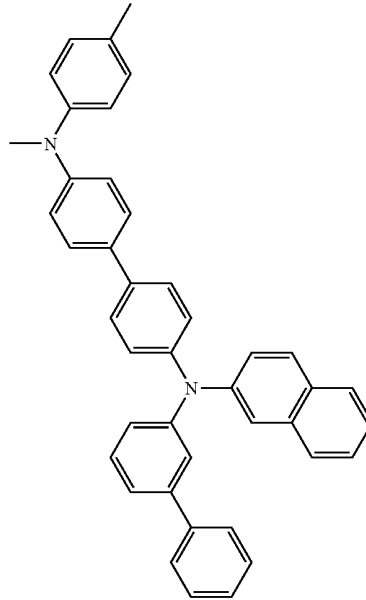

**169**  
-continued

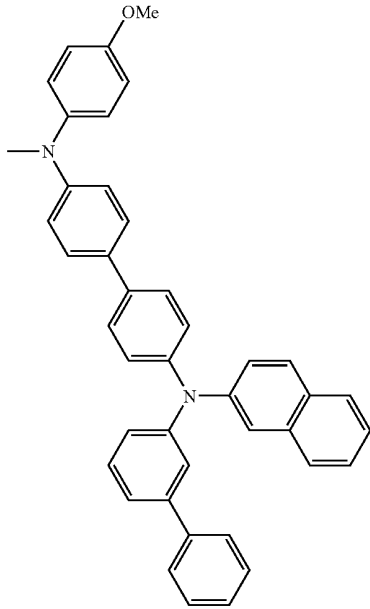

5

437

**170**  
-continued

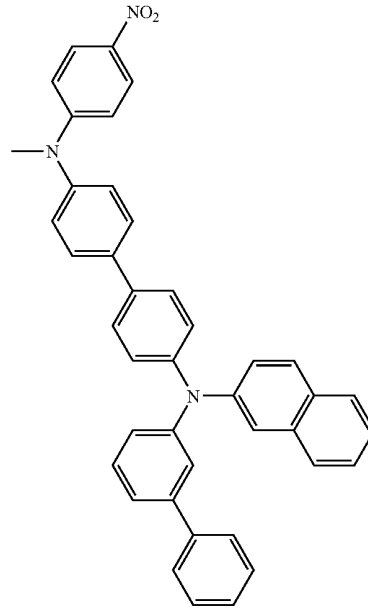

439

10

15

20

25

30

35

40

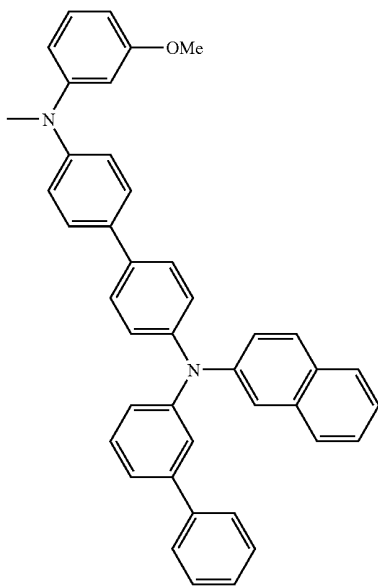

438

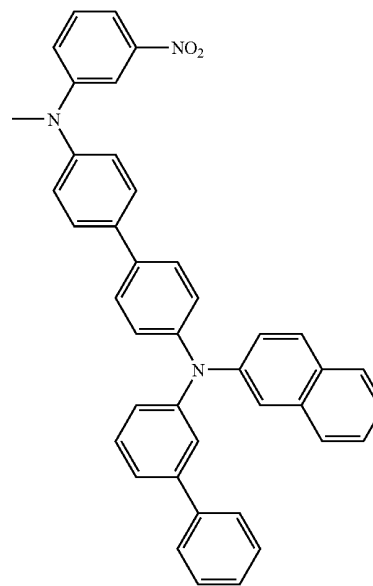

440

45

50

55

60

65

**171**  
-continued

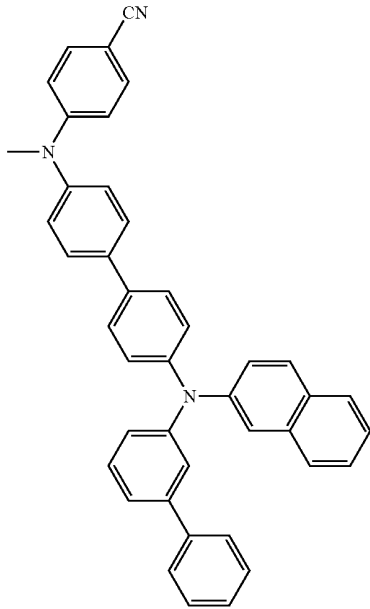

**172**  
-continued

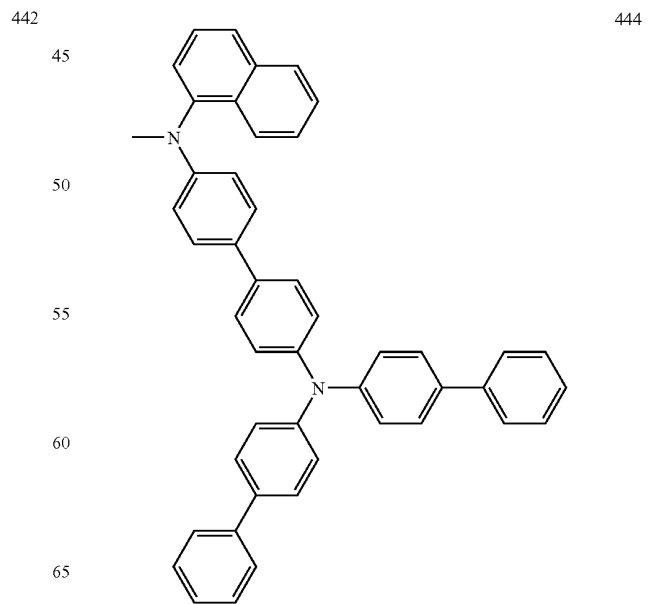
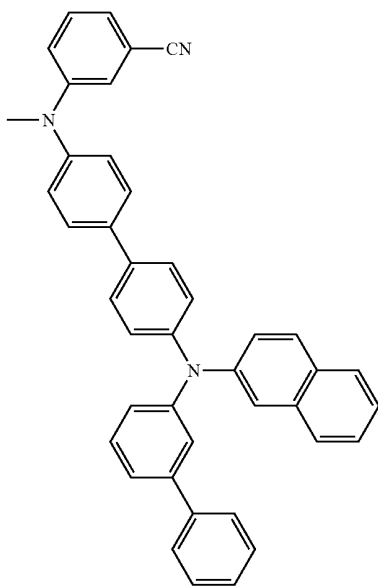
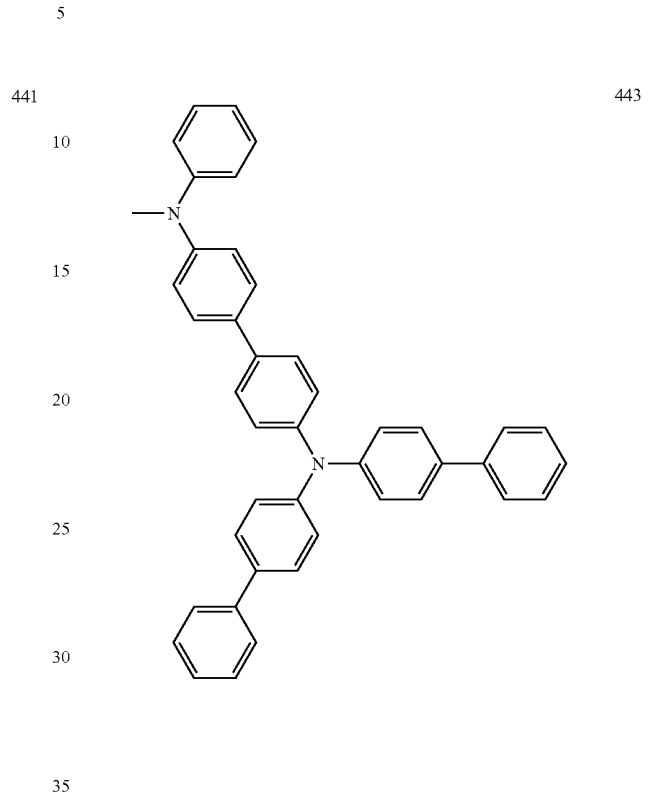

**173**  
-continued

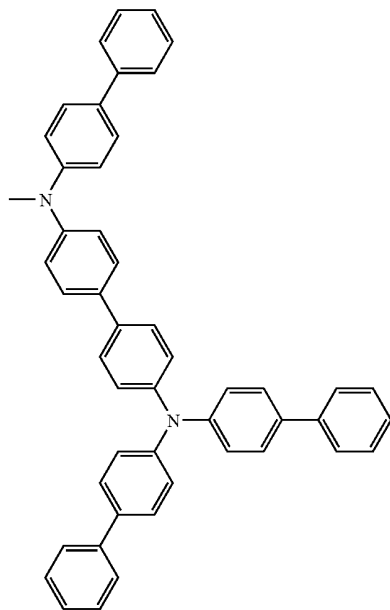
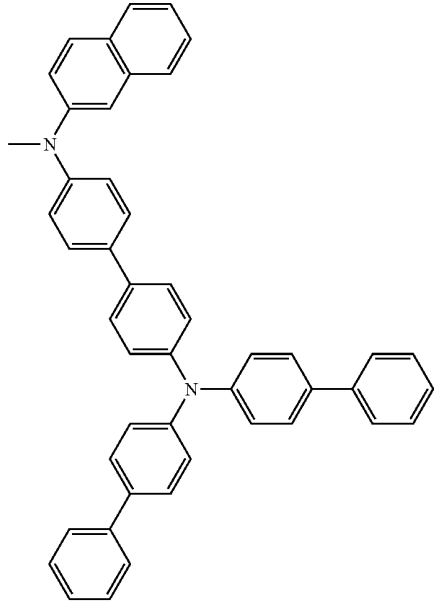

**174**  
-continued

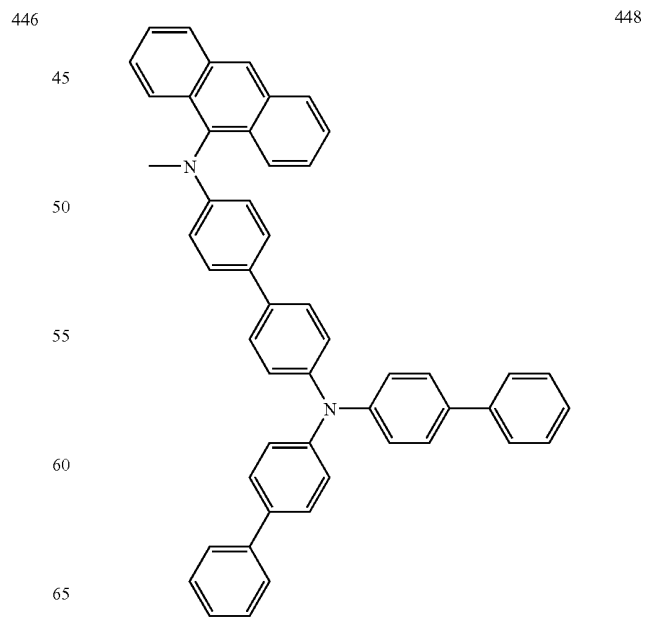
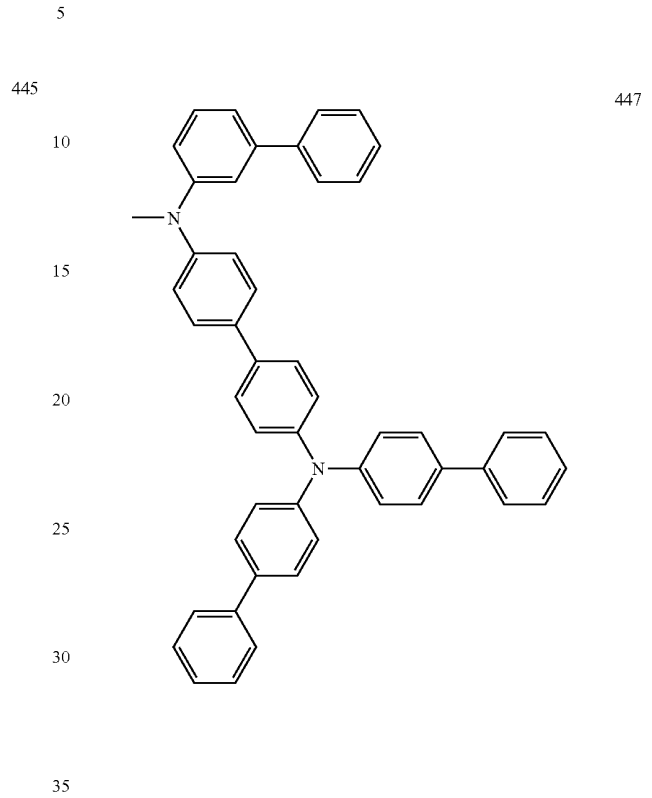

**175**  
-continued

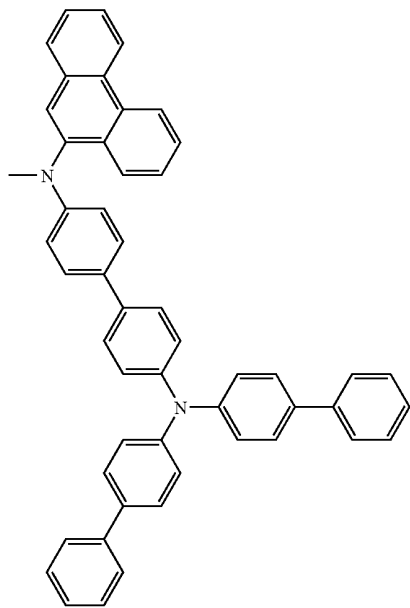
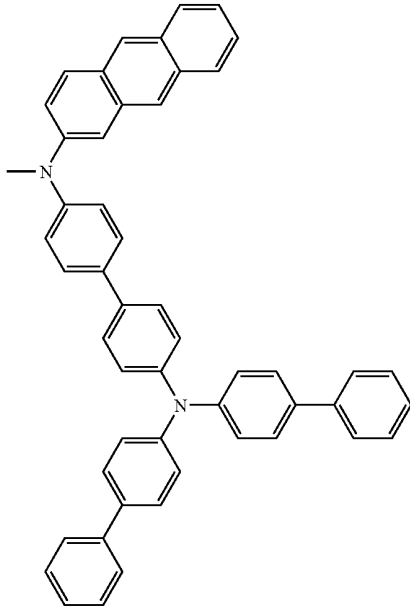

**176**  
-continued

5

449

10

15

20

25

30

35

40

450

45

50

55

60

65

451

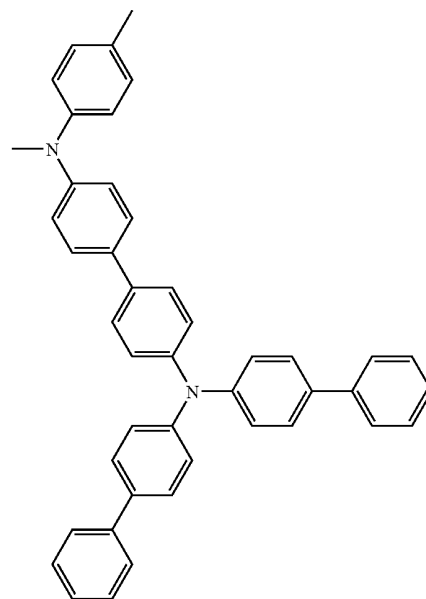
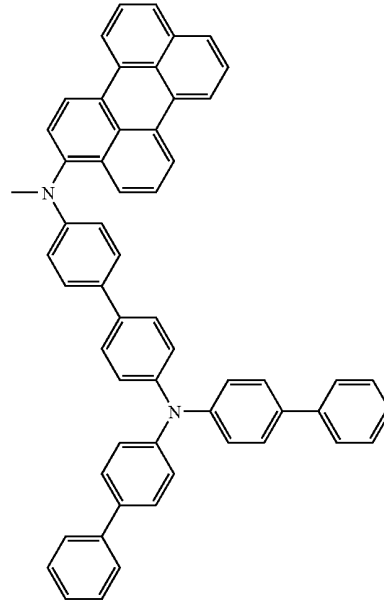

452

**15**  
-continued

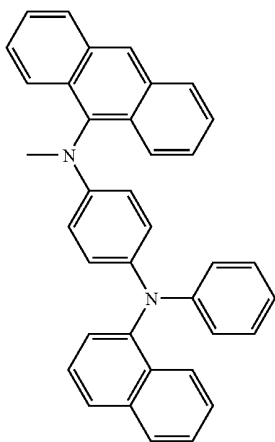
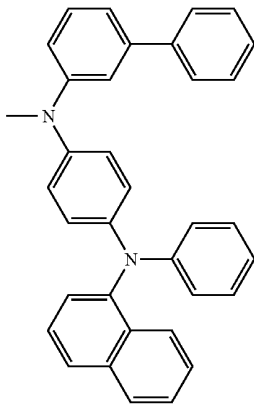
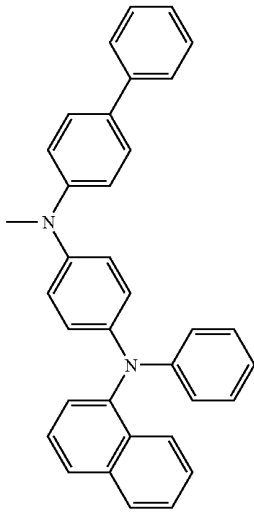

**16**  
-continued

21 5

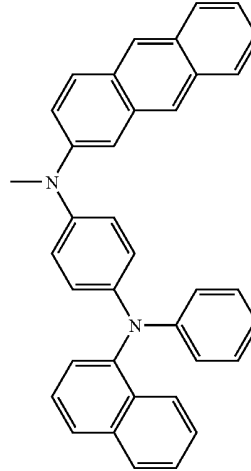

24

10

15

20

25

22

30

35

40

45

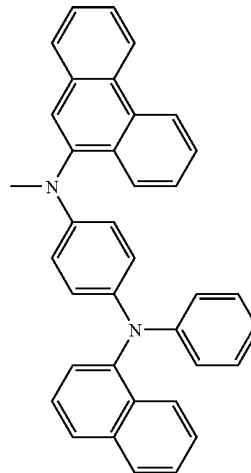

25

23

50

55

60

65

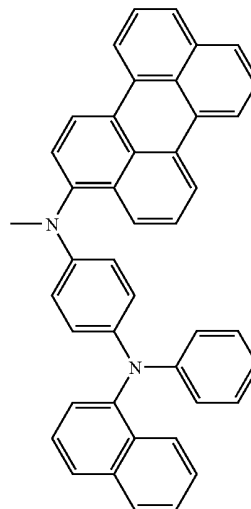

26

177  
-continued

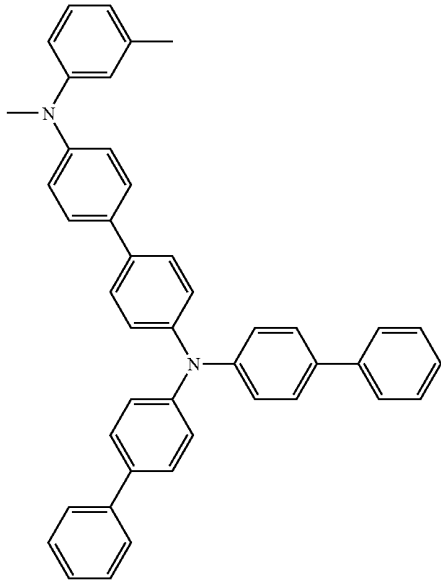

5

453

10

15

20

25

30

35

40

178  
-continued

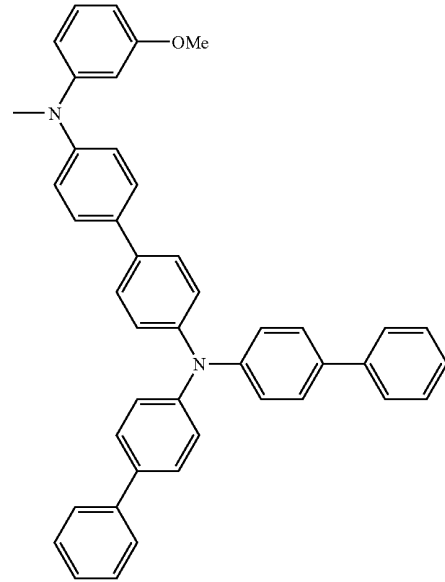

455

454

45

50

55

60

65

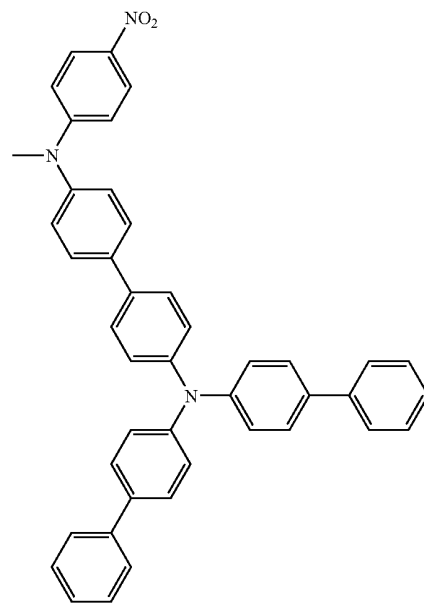
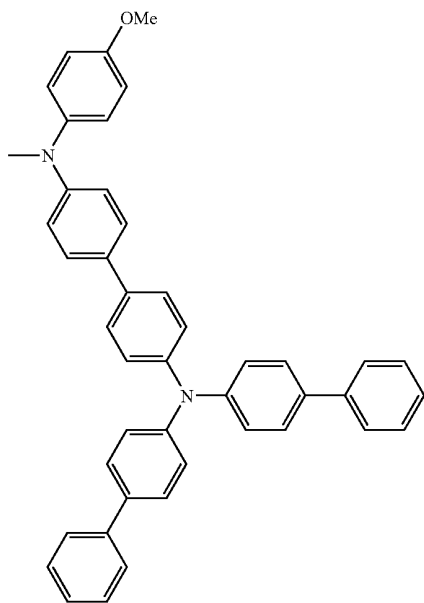

456

**179**  
-continued

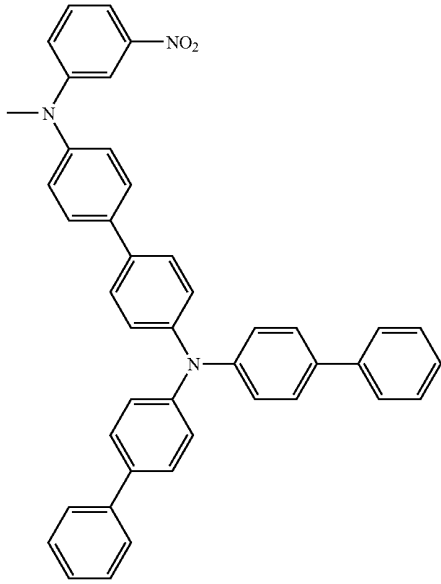

**180**  
-continued

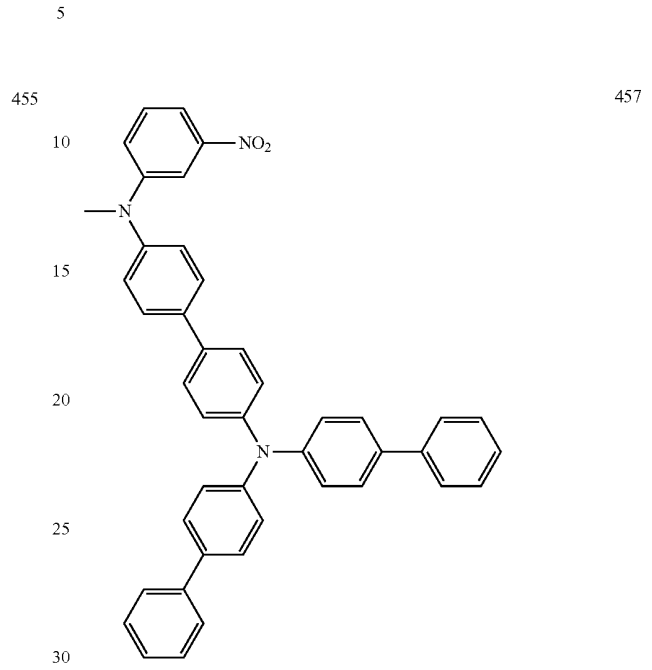

35

40

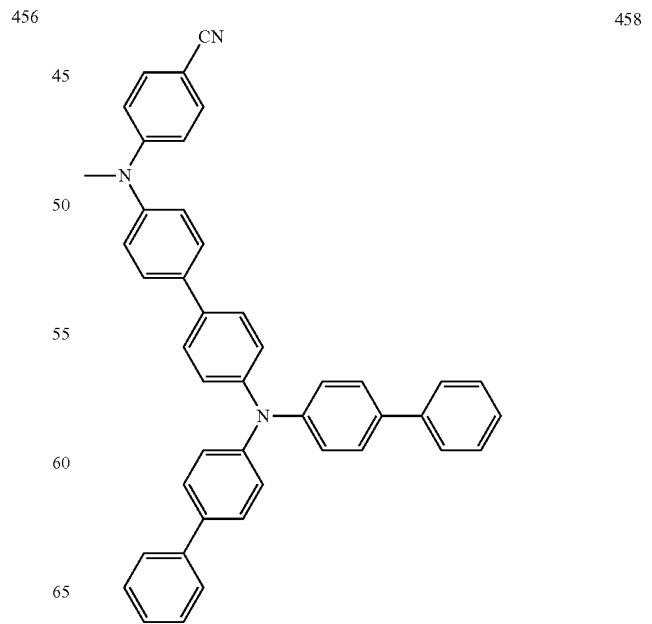
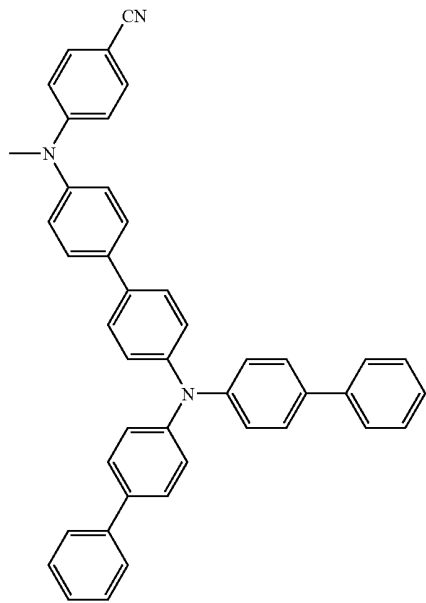

**181**  
-continued

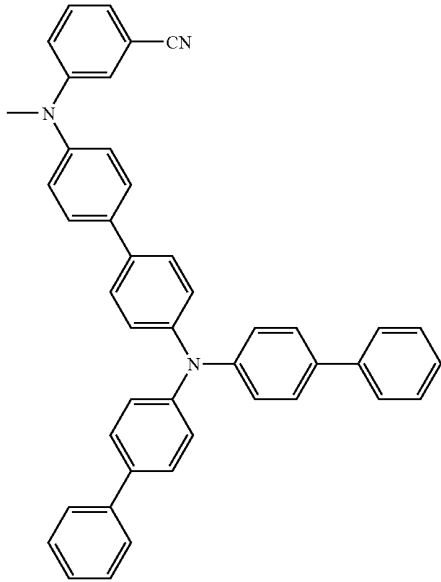

5

459

10

15

20

25

30

35

40

460

45

50

55

60

65

**182**  
-continued

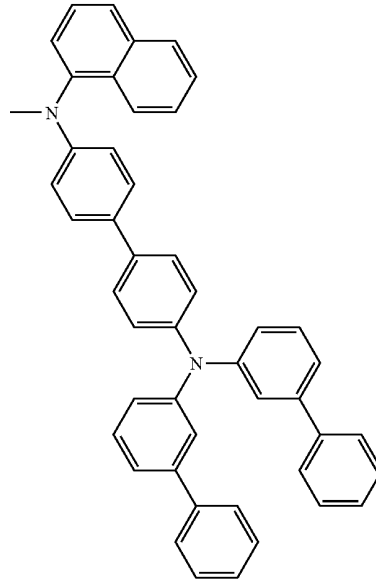

461

462

**183**  
-continued

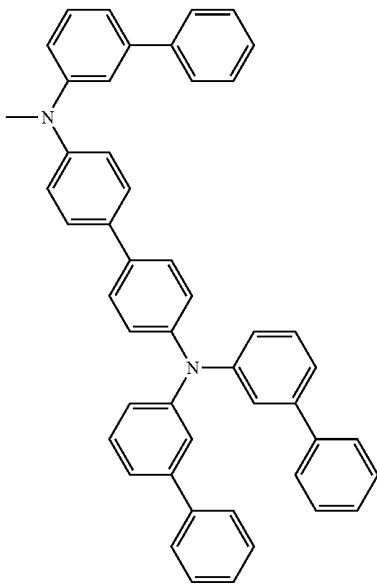
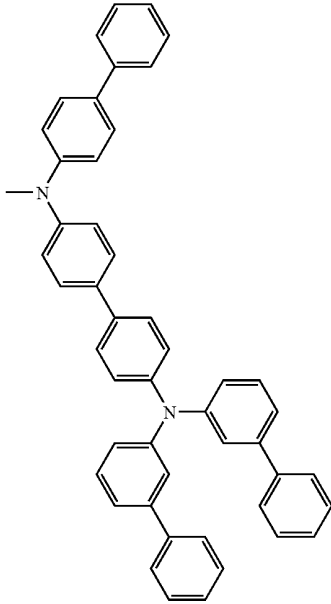

**184**  
-continued

5

463

465

10

15

20

25

30

35

40

464

466

45

50

55

60

65

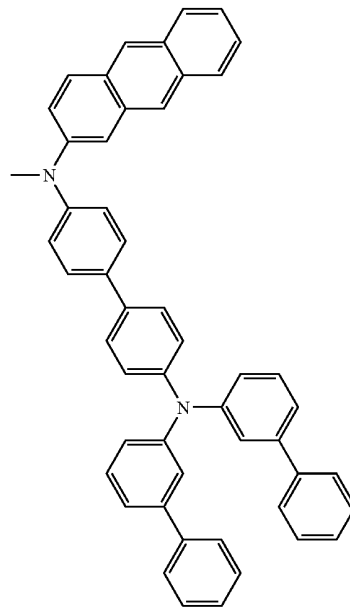
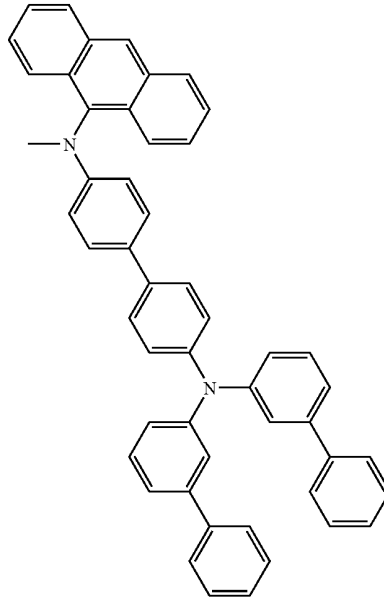

**185**  
-continued

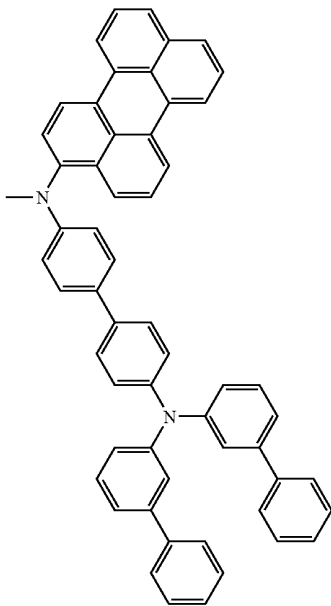
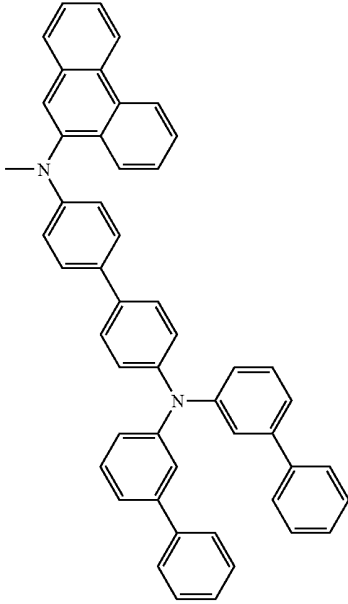

**186**  
-continued

5

467

469

10

15

20

25

30

35

40

468

470

45

50

55

60

65

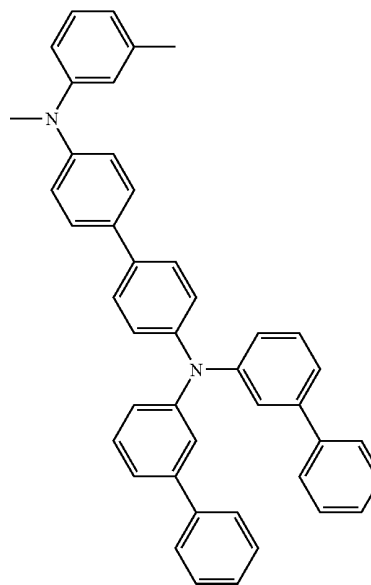
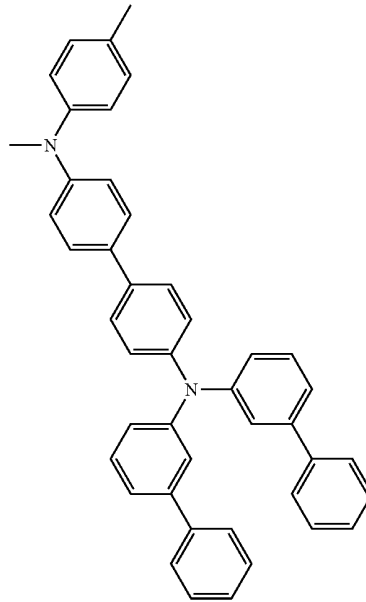

**187**  
-continued

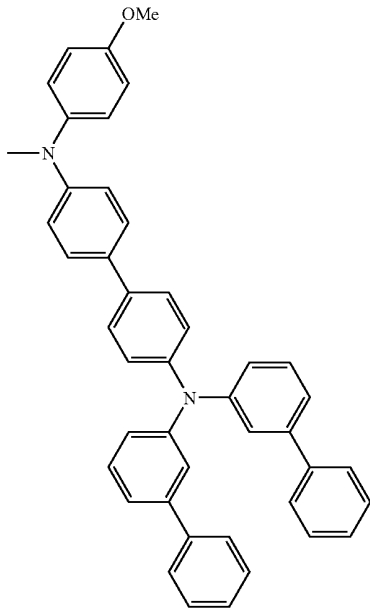

**188**  
-continued

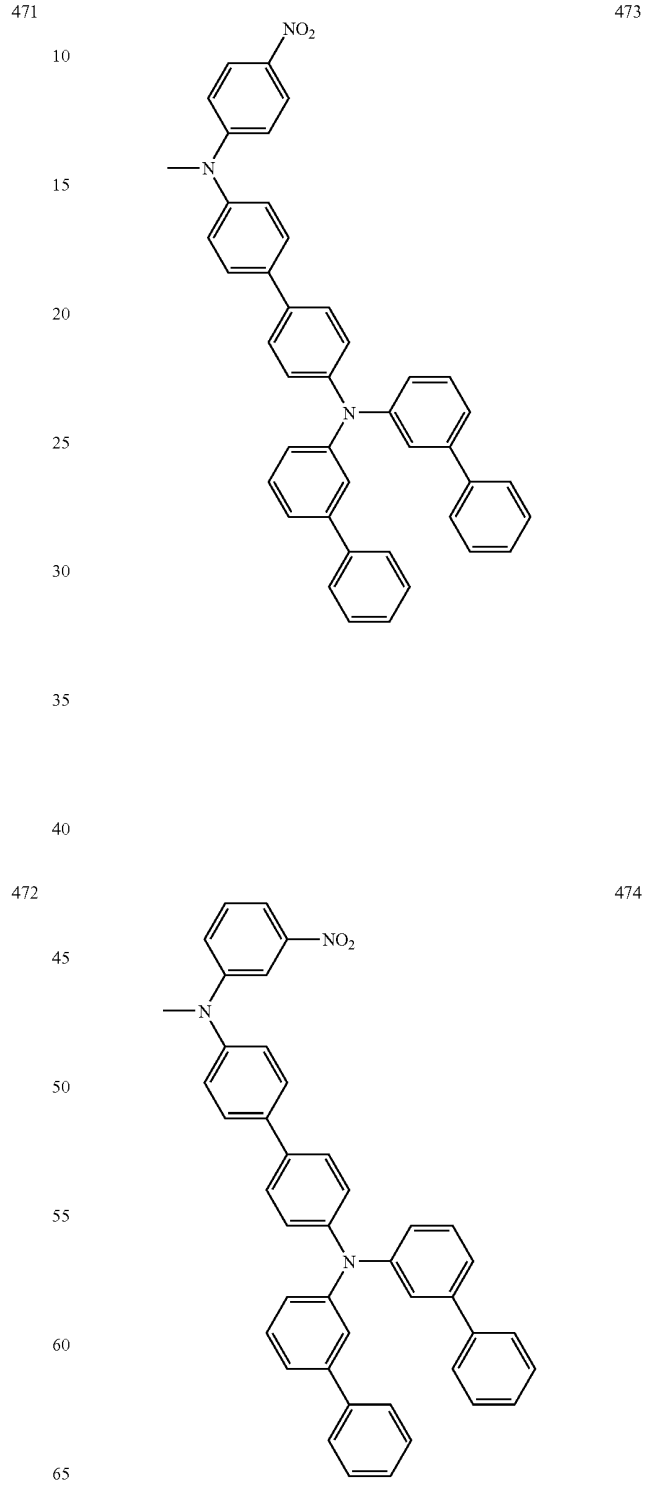

**189**  
-continued

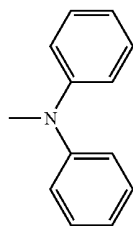
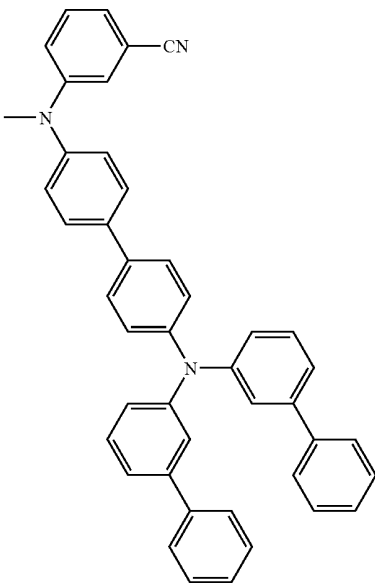
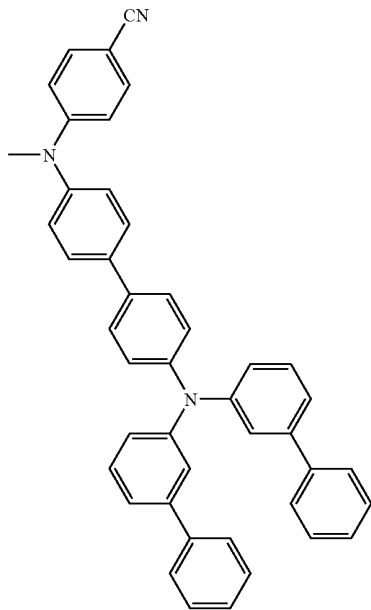

**190**  
-continued

475 5

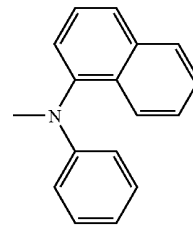

478

10

15

20

25

30

476

479

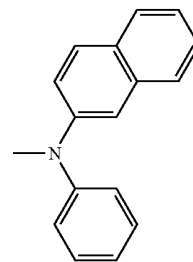

35

40

45

50

55

477

480

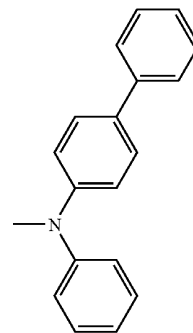

481

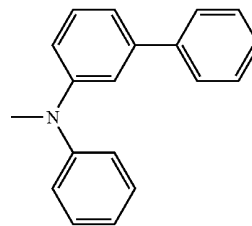

482

60

65

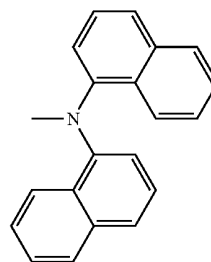

191

-continued

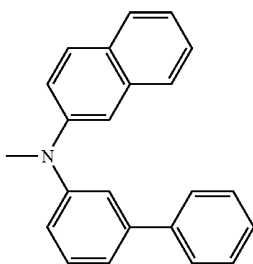
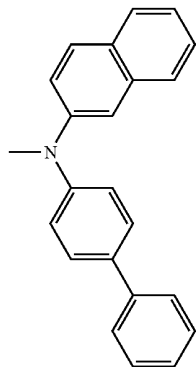
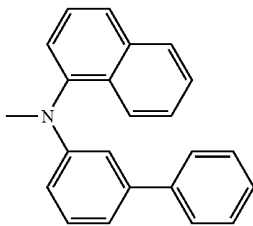
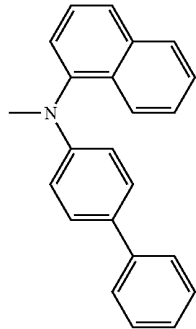
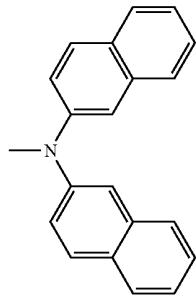

192

-continued

483

5

10

484 15

20

25

485

30

35

486

40

45

50

55

487

60

65

488

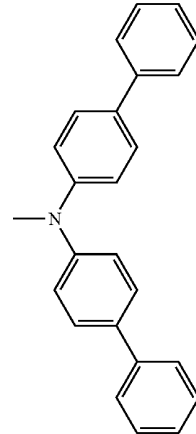

489

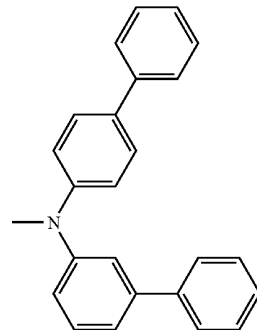

490

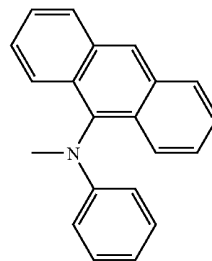

491

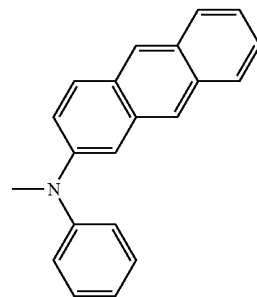

193

-continued

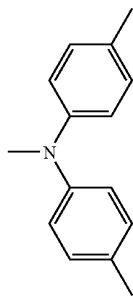
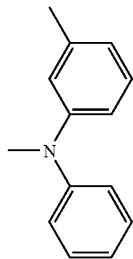
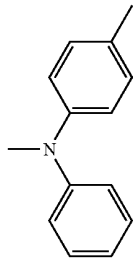
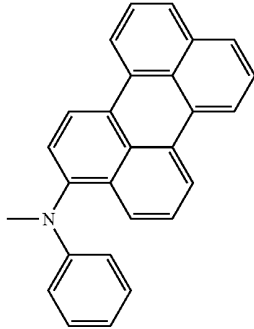
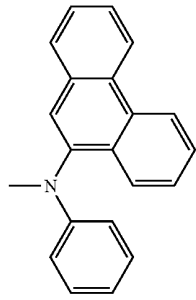

194

-continued

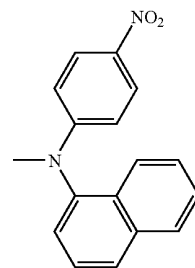
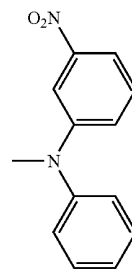
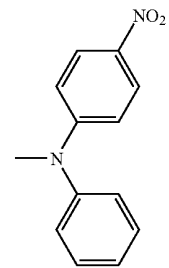
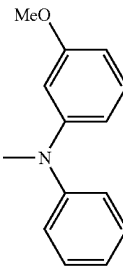
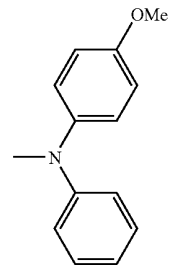

492

5

10

493

15

20

25

494

30

35

40

495

45

50

496

55

60

65

497

498

499

500

501

195

-continued

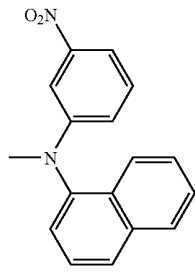

502

5

10

15

503

20

25

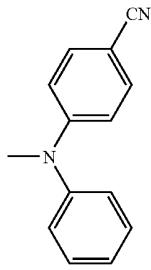

30

504

35

40

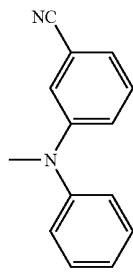

45

505

50

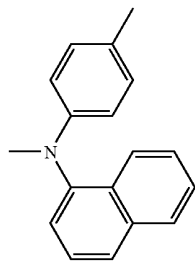

55

506

60

65

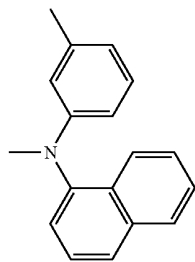

196

-continued

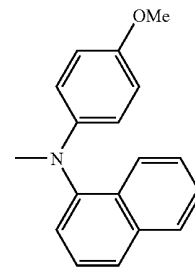

507

508

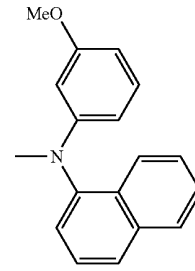

509

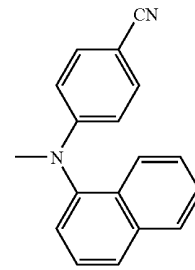

510

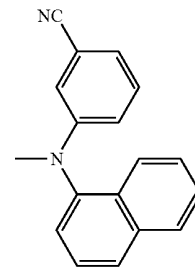

511

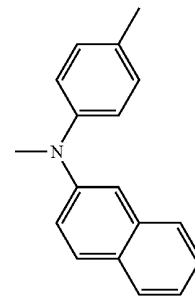

专利名称(译)	化合物和使用它的有机发光二极管		
公开(公告)号	<a href="#">US8071227</a>	公开(公告)日	2011-12-06
申请号	US12/312856	申请日	2007-12-03
[标]申请(专利权)人(译)	JEON BYUNG SUN CHO董旭 KIM JEUNG GON JEON SANG YOUNG 金素妍HWAN		
申请(专利权)人(译)	全度炳孙 CHO旭-DONG KIM JEUNG-GON 全度SANG-YOUNG 金素妍焕		
当前申请(专利权)人(译)	LG化学有限公司.		
[标]发明人	JEON BYUNG SUN CHO WOOK DONG KIM JEUNG GON JEON SANG YOUNG KIM YEON HWAN		
发明人	JEON, BYUNG-SUN CHO, WOOK-DONG KIM, JEUNG-GON JEON, SANG-YOUNG KIM, YEON-HWAN		
IPC分类号	H01L51/54		
CPC分类号	C07D209/86 C07D403/04 C07D471/04 C07D471/06 C07D487/04 C07D487/22 H01L51/006 H01L51/0061 H01L51/0072 H01L51/5048 H01L51/5088		
助理审查员(译)	CLARK , GREGORY		
优先权	1020060120557 2006-12-01 KR		
其他公开文献	US20100065828A1		
外部链接	<a href="#">Espacenet</a> <a href="#">USPTO</a>		

#### 摘要(译)

公开了新化合物和使用其的有机发光二极管。使用根据本发明的新化合物的有机发光二极管在致动电压，光效率和寿命方面表现出优异的特性。

